

BL3—B Series Parallel Elevator Controller User Guide

Doc No. IEC-30.01-111212

Content

| | |
|---|-----------|
| Content | 1 |
| Chapter 1: SAFETY INFORMATION | 1 |
| 1.1. LABEL DESCRIPTION | 1 |
| 1.2. SAFETY PRECAUTIONS..... | 1 |
| 1.3. Warning Labels on the Inverter | 5 |
| Chapter 2: Introduction and Installation | 6 |
| 2.1. Inverter Model Numbers | 6 |
| 2.2. Nameplate Information..... | 6 |
| 2.3. Inverter Specifications..... | 7 |
| 2.4. Product Appearance..... | 9 |
| 2.5. Exterior Dimension..... | 10 |
| 2.5.1. Open Type Inverters..... | 10 |
| 2.5.2. Close Type | 13 |
| 2.6. Confirmation upon Delivery..... | 13 |
| 2.7. Installation..... | 14 |
| 2.7.1. Installation Site..... | 14 |
| 2.7.2. Temperature Requirement | 14 |
| 2.7.3. Protect the inverter from Foreign Object | 14 |
| 2.7.4. Removing and attaching the Terminal Cover..... | 14 |
| 2.7.5. Remove/Attach Hand operator..... | 15 |
| 2.7.6. Installation Orientation and Space..... | 16 |
| 2.8. Equip Brake Resistor | 17 |
| 2.9. Product Function..... | 18 |
| Chapter 3: Wiring | 25 |
| 3.1. Connection Diagram for Elevator Integrated Controller..... | 26 |

| | |
|--|-----------|
| 3.2. Wiring Main circuit Terminals | 27 |
| 3.2.1. Main circuit structure..... | 27 |
| 3.2.2. Terminal arrangement for Main circuit..... | 27 |
| 3.2.3. Main circuit terminal summary and function instruction | 27 |
| 3.2.4. Wire specification for main circuit wiring | 28 |
| 3.2.5. Main circuit wiring | 29 |
| 3.3. Wiring Control Circuit Terminals..... | 30 |
| 3.3.1. Terminal Arrangement for Control Circuit | 30 |
| 3.3.2. Terminal Connection for Control Circuit (Figure 3.1)..... | 31 |
| 3.3.3. Control Circuit Port definition and Function | 31 |
| 3.3.4. Wire size for Control Circuit Terminals | 33 |
| 3.3.5. Control Circuit I/O interface and wiring..... | 34 |
| 3.4. PG Card Installation & Wiring | 36 |
| 3.4.1. PG_V31 Interface Card..... | 36 |
| 3.4.2. Installation and Remove PG_V31..... | 36 |
| 3.4.3. PG_V31 Terminal Definition & Function List..... | 37 |
| 3.4.4. PG_V31 Connection for 12V push-pull/OC output encoder (for Asynchronous Machine) | 38 |
| 3.4.5. PG_V31 card connection with 5V long cable drive output encoder (for Asynchronous Machine) | 38 |
| 3.4.6. PG_V31 card connection with 5V long cable drive output encoder (for Synchronous Machine) | 39 |
| 3.4.7. Precautions for using PG_V31 card..... | 39 |
| 3.4.8. SPG_V33 Interface Card | 40 |
| 3.4.9. SPG_V33 Interface Card Terminal Definition and Function List | 40 |
| 3.4.10. SPG_V33 Interface Card Circuit..... | 41 |
| 3.4.11. Precautions for using SPG_V33..... | 41 |
| 3.5. Precautions with Wiring..... | 42 |
| Chapter 4: Operator | 43 |

| | |
|---|-----------|
| 4.1. Key, display and function of Operator | 43 |
| 4.1.1. Operator LED Display | 43 |
| 4.1.2. Operator Keys | 44 |
| 4.1.3. LCD Display..... | 45 |
| 4.1.4. Function of Operator | 46 |
| 4.1.5. Installation and Connection of Operation..... | 46 |
| 4.2. Structure flowchart of Operator menu | 47 |
| 4.3. Parameter Setting | 48 |
| 4.4. Commissioning Parameters | 49 |
| 4.5. Save Parameter | 51 |
| 4.6. Hoistway Learning..... | 51 |
| 4.7. Motor Auto-tuning..... | 52 |
| 4.8. Motor Load Tuning..... | 52 |
| 4.9. Time Setting | 53 |
| 4.10. Fault Record Check..... | 53 |
| 4.11. Environment Initialization | 54 |
| 4.12. Parameter Copy | 56 |
| 4.13. Restore to Factory Setting..... | 56 |
| 4.14. Blue-Light Traction machine Parameter Input..... | 57 |
| Chapter 5: Parameters..... | 58 |
| 5.1. Parameters Function Classifications | 58 |
| 5.2. Parameters Hierarchical Structure..... | 58 |
| 5.3. Monitoring Parameters..... | 59 |
| 5.3.1. Hoistway Location (U0) | 59 |
| 5.3.2. Monitoring Parameter for I/O Status, Cabin Signal & Interference Appraisal (U1-U5) | 60 |
| 5.3.3. Drive Monitoring Parameters | 62 |

| | |
|--|-----------|
| 5.4. Parameters setup Function Instruction | 62 |
| 5.4.1. Building Setup Parameters (F0)..... | 62 |
| 5.4.2. Parameters for Running Setup (F1)..... | 63 |
| 5.4.3. Time Setup Parameters (F2)..... | 66 |
| 5.4.4. Input type setup Parameters (F3) | 68 |
| 5.4.5. Service Setup Parameters (F4) | 69 |
| 5.4.6. Motor Setup Parameters (F5-F6) | 70 |
| 5.4.7. Multiple PI Setup Parameters (F7) | 71 |
| 5.4.8. Encoder Setup Parameters (F8) | 71 |
| 5.4.9. Control Setup Parameters (F9)..... | 72 |
| 5.4.10. No-load Compensation Setup Parameters (FA) | 72 |
| 5.4.11. Special Parameters (FC) | 73 |
| 5.4.12. Environment Setup Parameters (A) | 73 |
| Chapter 6: Parameters Setup | 74 |
| 6.1. Elevator Running Speed Setup | 74 |
| 6.1.1. Elevator Rated Speed, Motor Rated Speed, Encoder pulses Setup | 74 |
| 6.1.2. Inspection Run Speed..... | 74 |
| 6.1.3. Rescue Speed | 74 |
| 6.1.4. Least Speed | 75 |
| 6.2. Normal Running Speed Curve | 75 |
| 6.3. Elevator Running Timing Diagram..... | 76 |
| 6.3.1. Timing Diagram for Normal Running | 76 |
| 6.3.2. Timing Diagram for Inspection Running..... | 78 |
| 6.3.3. Timing Diagrams for Rescue Running | 79 |
| 6.3.4. Timing Diagram for Recalibration Running | 79 |
| 6.4. Door Control..... | 80 |

| | |
|--|----|
| 6.4.1. Door Open/Close Control..... | 80 |
| 6.4.2. Door Open Holding Time..... | 81 |
| 6.4.3. Door Control in Attendant and Special use mode | 81 |
| 6.4.4. Door Control in Inspection, Fire mode..... | 81 |
| 6.5. Homing Function Setup..... | 81 |
| 6.6. Parking Function Setup | 81 |
| 6.7. Fireman Operation Function Setup..... | 82 |
| 6.8. Rear Door Control Setup | 82 |
| 6.8.1. Different Mode Selection..... | 82 |
| 6.8.2. Rear Door Condition Setup | 84 |
| 6.9. Input Type Setup..... | 84 |
| 6.10. Service Floor Setup..... | 85 |
| 6.11. Weighing Device Setup | 85 |
| 6.12. Duplex Control Setup | 86 |
| 6.13. Group Control Setup | 86 |
| 6.14. Leveling Adjustment Setup | 86 |
| 6.15. Floor Indication Setup | 86 |
| 6.16. Special Function Selection..... | 87 |
| 6.17. Motor Parameters Setup | 88 |
| 6.18. Elevator Running Speed Setup | 88 |
| 6.19. Speed Control Setup (PI Adjustment) | 89 |
| 6.19.1. Speed Control Setup with Single PI Adjustment | 89 |
| 6.19.2. Speed control Setup with Multi-Section PI Adjustment | 89 |
| 6.20. Load-Compensation Torque Output Setup..... | 90 |
| 6.21. Encoder Parameters Setup..... | 91 |
| 6.22. Start without Load Compensation Setup | 91 |

| | |
|---|-----------|
| Chapter 7: Commissioning | 94 |
| 7.1. Important Reminder | 94 |
| 7.2. Inspections before Power On..... | 94 |
| 7.3. Power On and Inspection | 95 |
| 7.3.1. Things need to confirm before Power On..... | 95 |
| 7.3.2. Inspection after Power On | 95 |
| 7.4. Parameter Setup | 96 |
| 7.5. Motor Parameters Tuning..... | 96 |
| 7.5.1 Motor Rotation Tuning | 96 |
| 7.5.2 Motor Static Tuning | 97 |
| 7.6. Motor Initial Angle Tuning | 97 |
| 7.6.1. Tuning Procedures for Machine with Incremental Encoder | 98 |
| 7.6.2. Tuning Procedures for Motor with Sine/Cosine Encoder | 98 |
| 7.6.2.1 Rotation Tuning..... | 98 |
| 7.6.2.2 Static Tuning..... | 99 |
| 7.7. Inspection Running..... | 100 |
| 7.7.1. Inspection Running in Machine Room | 100 |
| 7.7.2. Inspection Running on Car Top/Cabin | 100 |
| 7.8. Hoistway Learning..... | 101 |
| 7.9. Normal Speed Running | 101 |
| 7.10. Elevator Comfort Level Adjustment..... | 102 |
| 7.10.1. Adjustment for Start/Brake speed curve | 102 |
| 7.10.2. Follow & Adjust Running Curve..... | 103 |
| 7.10.3. Control Timing Adjustment..... | 103 |
| 7.11. Leveling Precision Adjustment | 104 |
| 7.11.1. Basic Conditions for Elevator Leveling | 104 |

| | |
|--|------------|
| 7.11.2. Leveling Parameter Adjustment | 104 |
| 7.12. Terminal Switch Position..... | 104 |
| Chapter 8: Troubleshooting | 105 |
| 8.1. Elevator System Faults | 105 |
| 8.2. Hoistway Parameter Self-Learning Faults | 107 |
| 8.3. Driver Faults | 108 |
| 8.4. Motor Initial Angle Tuning Faults..... | 109 |
| 8.5. Motor Parameters Tuning Faults | 111 |
| Chapter 9: Maintenance | 113 |
| 9.1. Safety Precautions for Drive Maintenance & Storage | 113 |
| 9.2. Daily Check..... | 113 |
| 9.3. Routine Inspection | 114 |
| 9.4. Quick Wear parts..... | 114 |
| 9.5. Warranty | 114 |
| Chapter10: Controller installation with EMC Standard | 115 |
| 10.1. EMC Briefing..... | 115 |
| 10.2. EMC Characteristics of Integrated Controller | 115 |
| 10.3. EMC Installation Guide..... | 115 |
| 10.3.1. Noise Control | 115 |
| 10.3.2. Wiring..... | 116 |
| 10.3.3. Ground Connection..... | 116 |
| 10.3.4. Leakage Current | 117 |
| 10.3.5. Power Line Filter | 117 |
| 10.4. EMC standard satisfied by Integrated Controller..... | 118 |
| Chapter 11: Accessories | 119 |
| 11.1. Elevator Parallel Connection Extension Board (BL2000-EBA)..... | 119 |

| | |
|--|------------|
| 11.1.1. Function | 119 |
| 11.1.2. Terminal Definition & Specification | 119 |
| 11.2. Elevator Group Control Board BL2000-QKB-V1 | 121 |
| 11.2.1 Function | 121 |
| 11.2.2 Application | 121 |
| 11.2.3 Terminal Specification..... | 121 |
| 11.2.4 Interface Circuit..... | 122 |
| 11.2.5 Terminal Definition & Specification | 122 |
| Appendix 1: Hoistway Switches Information (partly)..... | 123 |
| F1.1. Leveling Switches & Flag Installation | 123 |
| F1.1. Up/Down Terminal Switches Installation..... | 123 |
| F1.2. Confirm the Terminal Switches Location | 124 |
| Appendix 2: Parameters List | 125 |
| Appendix 3: Hoistway Parameter Learning Flowchart | 129 |
| Appendix 4: Motor Initial Angle Static Tuning Flowchart | 130 |

FOREWORD

Thank you for using BL3-B series elevator controller. BL3 series elevator integrated controller is the next generation elevator control system developed by Shenyang Bluelight Automatic Technology CO. LTD. It combines elevator intellectual logic control and high-performance VVVF drive control. With user friendly interface and advanced technology integrated together, the system not only has outstanding performance, but also shows strong reliability in practice.

- ◆ The system combines intellectual logic control and high-performance VVVF drive control.
- ◆ Adopts advanced vector control technology, demodulates motor with high precision, takes full advantage of motor capacity, improves elevator performance and comfort feel.
- ◆ Adopts advanced space vector PWM calculation method, compare with traditional sine/cosine PWM method, it improves elevator operation efficiency and saves more energy.
- ◆ Adopts full function of BL2000/3000 system, maximize the performance of elevator in different application.
- ◆ When using Bluelight Synchronous machine, controller could pre-define the machine type with the most optimized model, save machine parameter input and auto-tuning process, improves the commissioning efficiency and maximize the machine performance.
- ◆ Fuzzy logic control with non-load-compensation start-up. Excellent comfort feels without lift weighing device.
- ◆ Rotating or stopping auto-tuning to get motor parameters and initial angle.
- ◆ Suitable for both gearless PM Synchronous traction machine and asynchronous induction machine.
- ◆ Brake units are built in for the whole BL3-B series to reduce external component cost.
- ◆ Internal encoder and frequency dividing interface to match different PG signal.
- ◆ Advanced double 32 bit CPU and FPGA for complete elevator control, with high reliability on elevator safety.
- ◆ Redundancy design and full software-hardware protection to achieve elevator safety and reliability.
- ◆ Passed professional EMC test, suitable for complicated job site.
- ◆ Monitor the cutting current from controller to main motor every time elevator stops.
- ◆ Generate optimized speed curve based on target floor to enable lift stop directly with high efficiency.
- ◆ Adopts wireless/LAN remote control interface, convenient for long distance commissioning, maintenance and elevator monitoring.
- ◆ Equips upper monitoring and software, convenient for parameter setting, commissioning and debugging.
- ◆ Data recorder to save integrated controller operation data, help for onsite maintenance /trouble shooting.
- ◆ Parameter upload, download and copy to help onsite maintenance.
- ◆ Support ARD function with only UPS unit.
- ◆ Match GB7588-2003 (equivalent to EN-81) safety standard.

This user guide has introduced on how to use BL3-B series elevator controller. Please read it carefully and understand safety items before use (installation, running maintenance). This user guide is for elevator designer, installation and maintenance technician. The installation, commissioning and maintenance must be performed by train technician.

The intellectual property of this user guide is owned by Shenyang Bluelight Group. Any information from this user guide should not be copied without permission.

Chapter 1: SAFETY INFORMATION

1.1. LABEL DESCRIPTION

The following conventions are used to indicate precautions in this user guide. Failure to notice the precautions provided in this user guide can result in serious or even fatal injury to damage to the products or to related equipment and systems.



Indicates precautions that if not heeded could possibly result in loss of life or serious injury.





Indicates precautions that if not heeded could result in relatively serious or minor injury to the operator and damage to the product. Also, it should be noted that even for  precautions, in certain situations could result in serious accident.





Indicate important information that should be memorized.

1.2. SAFETY PRECAUTIONS

◆ Confirmation upon Delivery

| |
|--|
|  注意  |
| <ul style="list-style-type: none"> ◇ Never install an integrated controller that is damaged or missing components. Doing so can result in injury. |

◆ Installation

| |
|---|
|  注意  |
| <ul style="list-style-type: none"> ◇ Always hold the case when carrying the integrated controller Otherwise the integrated controller may drop and damage. ◇ Please install the device to a metal surface or other non-flammable objects Otherwise there is a fire-hazard potential. ◇ Please mount the device to an object that are strong enough. Otherwise the integrated controller may drop and damage. ◇ Please install the device in a dry place where water or rain could not get into. Otherwise the integrated controller could get damaged. ◇ For the same cabinet to install the integrated controller and brake resistor, install cooling fan or other cooling device and make sure the air temperature entering is below 45°C Overheat can result in fires or other accidents. ◇ Do not leave any metallic objects inside the integrated controller Otherwise it may damage the device and has fire-hazard potential. |

◆ Wiring



- ◇ **Always turn OFF the input power supply before wiring terminals.**
Otherwise, an electric shock or fire can occur.
- ◇ **Wiring must be performed by an authorized person qualified in electrical work.**
Otherwise, an electric shock or fire can occur.
- ◇ **Be sure to ground the ground terminal. (200 V Class: Ground to 100 Ω or less, 400 V Class: Ground to 10 Ω or less)**
Otherwise, an electric shock or fire can occur.
- ◇ **Always check the operation of any fast stop circuits after they are wired.**
Otherwise, there is the possibility of injury. (Wiring is the responsibility of the user.)
- ◇ **Never touch the output terminals directly with your hands or allow the output lines to come into contact with the Inverter case. Never short the output circuits.**
Otherwise, an electric shock or ground short can occur.
- ◇ **Do not use the Inverter for any load other than a three-phase AC motor. • A permanent magnet motor is a type of permanent magnet motor with a rotor in which a magnet is integrated. Unlike an induction motor, the permanent magnet motor terminal generates high voltage when the motor is running, even when the Inverter power is shut off. Be sure to completely stop the motor before wiring, maintenance and inspection.**
Failure to do so may result in electric shock.



- ◇ **Check to be sure that the voltage of the main AC power supply satisfies the rated voltage of the Inverter.**
Injury or fire can occur if the voltage is not correct.
- ◇ **Do not perform voltage withstand tests on the Inverter.**
Otherwise, semiconductor elements and other devices can be damaged.
- ◇ **Connect braking resistors, Braking Resistor Units, and Braking Units as shown in the I/O wiring examples.**
Otherwise, a fire can occur and the Inverter, braking resistors, Braking Resistor Units, and Braking Units can be damaged.
- ◇ **Tighten all terminal screws to the specified tightening torque.**
Otherwise, a fire may occur.
- ◇ **Do not connect AC power to output terminals U, V, and W.**
The interior parts of the Inverter will be damaged if voltage is applied to the output terminals.
- ◇ **Do not connect phase-advancing capacitors or LC/RC noise filters to the output circuits.**
The Inverter can be damaged or interior parts burnt if these devices are connected.
- ◇ **When a magnetic contactor is connected to the output circuits, do not switch it ON and OFF while the Inverter is running.**
Surge current will cause the over current protection circuit inside the Inverter to operate.
- ◇ **Do not make terminal E⁺ / P1 and E⁻ short link.**
Otherwise, a fire or explode may occur.

◆ Trial Operation



- ◇ **Check to be sure that the front cover is attached before turning ON the power supply.**
Otherwise, an electric shock may occur.
- ◇ **Do not get close to machine and related objects when choosing the error auto reset function, as the drive will automatically restart after warning reset.**
Otherwise, an injury may occur.
- ◇ **Provide a separate fast stop switch; the Digital Operator STOP Key is valid only when its function is set.**
Otherwise, an Injury may occur.
- ◇ **Reset alarms only after confirming that the RUN signal is OFF.**
Otherwise, an Injury may occur.
- ◇ **Do not perform fault operation and signal checking while the drive is running.**
Otherwise an injury may occur and the drive may get damaged.



- ◇ **Do not touch the radiation fins (heat sink), braking resistor, or Braking Resistor Unit. These can become very hot.**
Otherwise, a burn injury may occur.
- ◇ **Be sure that the motor and machine is within the applicable ranges before starting operation.**
Otherwise, an injury may occur.
- ◇ **Provide a separate holding brake if necessary. Always construct the external sequence to confirm that the holding brake is activated in the event of an emergency, a power failure, or an abnormality in the Inverter.**
Failure to observe this caution can result in injury.
- ◇ **If using an Inverter with a elevator, take safety measures on the elevator to prevent the elevator from dropping.**
Failure to observe this caution can result in injury.
- ◇ **Do not check signals while the Inverter is running.**
Otherwise, the equipment may be damaged.
- ◇ **Be careful when changing Inverter settings. The Inverter is factory set to suitable settings.**
Otherwise, the equipment may be damaged.

◆ Maintenance and Inspection



- ◇ **Do not touch the Inverter terminals. Some of the terminals carry high voltages and are extremely dangerous.**
Doing so can result in electric shock.
- ◇ **Always have the protective cover in place when power is being supplied to the Inverter. When attaching the cover, always turn OFF power to the Inverter through the MCCB.**
Doing so can result in electric shock.
- ◇ **After turning OFF the main circuit power supply, wait for the time indicated on the front cover, and make sure the CHARGE indicator light has gone out, and then perform maintenance and inspection.**
The capacitor will remain charged and is dangerous.
- ◇ **Maintenance, inspection, and replacement of parts must be performed only by authorized personnel. Remove all metal objects, such as watches and rings, before starting work. Always use grounded tools.**
Failure to heed these warning can result in electric shock.
- ◇ **Be sure to completely stop the permanent magnet motor before maintenance and inspection.**
Failure to do so may result in electric shock.



- ◇ **A CMOS IC is used in the control board. Handle the control board and CMOS IC carefully.**
The CMOS IC can be destroyed by static electricity if touched directly.
- ◇ **Do not change the wiring, or remove connectors or the Digital Operator, during operation.**
Doing so can result in personal injury.

◆ Other



- ◇ **Do not attempt to modify or alter the Inverter.**
Doing so can result in electrical shock or injury.

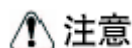

- ◇ **Do not subject the Inverter to halogen gases, such as fluorine, chlorine, bromine, and iodine, at anytime even during transportation or installation.**
Otherwise, the Inverter can be damaged or interior parts burnt.

1.3. Warning Labels on the Inverter

Be sure to read and follow all warning labels on the Inverter before installation.

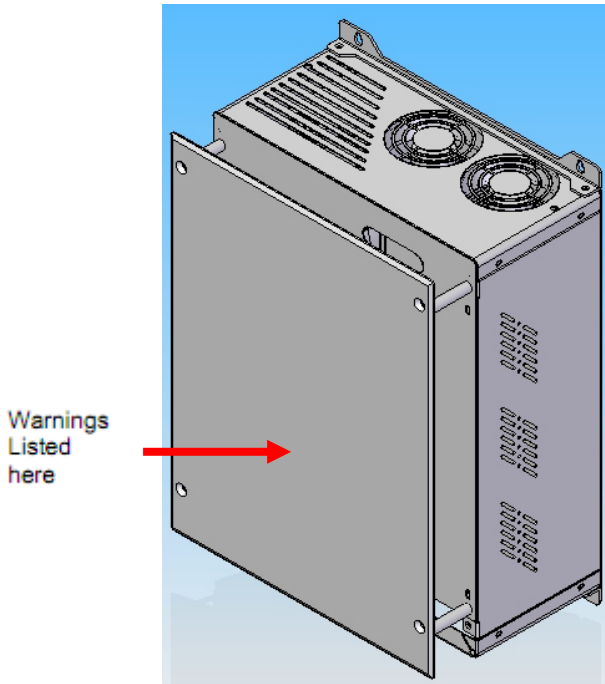

FIGURE 1.1 OPEN TYPE

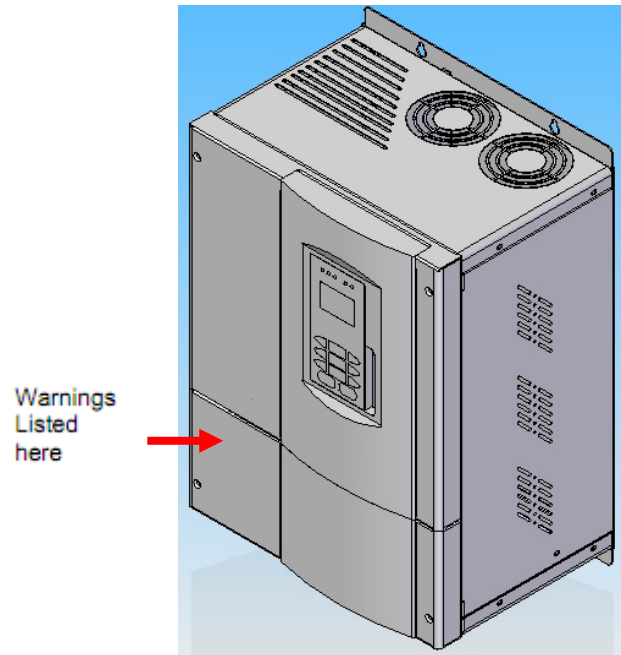

FIGURE 1.2 CLOSE TYPE

Text on Warning Labels



FIGURE 1.3 WARNING LABEL CONTENT

Chapter 2: Introduction and Installation

This chapter describes the checks required upon receiving or installing an Inverter.

2.1. Inverter Model Numbers

The model number of the Inverter on the nameplate indicates the specification, voltage class, and maximum motor capacity of the Inverter in alphanumeric codes. Please see below figure 2.1 for example (22kw

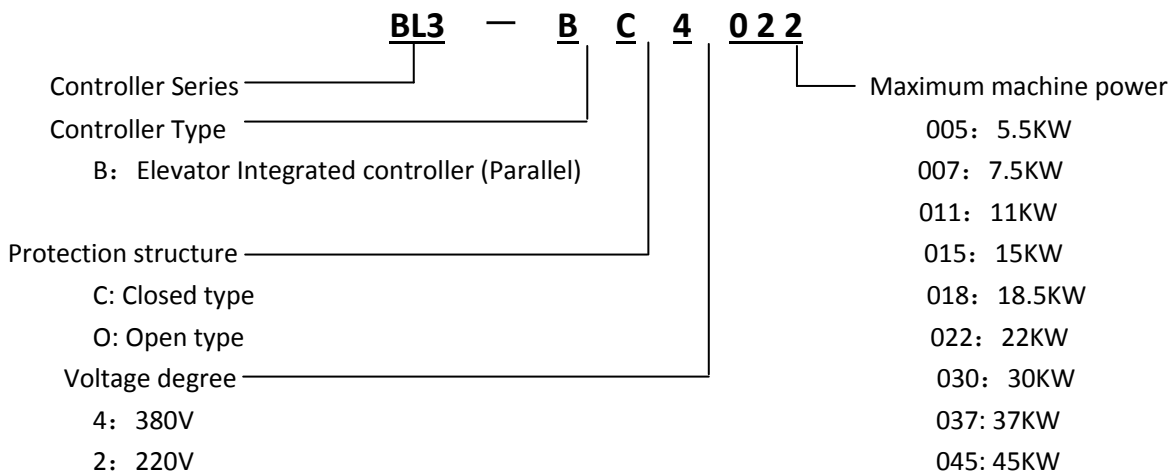

FIGURE 2.1 INVERTER MODEL NUMBERS

2.2. Nameplate Information

Nameplate information can be seen in figure 2.2 below.

There is a nameplate attached to the side of each Inverter. The nameplate shows the model number, specifications, lot number, serial number, and other information about the Inverter.

Example

The following nameplate is an example for a standard BL3-B Inverter: 3-phase, 400 VAC, 22Kw.

| | | |
|-------------|-------------------------|----------------|
| 型号(MODEL): | BL3-BC4022 | POW:22KW |
| 输入(INPUT): | AC3PH 380V 50 Hz 58A | |
| 输出(OUTPUT): | AC3PH 0-380V 0-50Hz 48A | |
| 序列号(S/N): | | 重量(MASS): 20Kg |
| (bar code) | | |

FIGURE 2.2 NAMEPLATE

2.3. Inverter Specifications

BL3—U series elevator integrated controller specifications are listed in the following tables.

TABLE 2.1 STANDARD SPECIFICATIONS

| MODEL BL3—B□40□□ | | 4005 | 4007 | 4011 | 4015 | 4018 | 4022 | 4030 | 4037 | 4045 |
|----------------------|-----------------------------|--|------|------|------|------|------|------|------|------|
| MAX MOTOR POWER (KW) | | 5.5 | 7.5 | 11 | 15 | 18.5 | 22 | 30 | 37 | 45 |
| RATED OUTPUT | RATED OUTPUT POWER (KVA) | 9 | 12 | 18 | 22 | 27 | 32 | 43 | 53 | 63 |
| | RATED OUTPUT CURRENT (A) | 14 | 18 | 27 | 34 | 41 | 48 | 65 | 80 | 96 |
| | MAX OUTPUT VOLTAGE (V) | 3-phase, AC380 (match the input voltage) | | | | | | | | |
| | RATED FREQUENCY (Hz) | 50 | | | | | | | | |
| | MAX OUTPUT FREQUENCY (Hz) | 120 | | | | | | | | |
| INPUT POWER | RATED VOLTAGE (V) | 3-phase AC380 | | | | | | | | |
| | RATED FREQUENCY (Hz) | 50 | | | | | | | | |
| | RATED INPUT CURRENT (A) | 17 | 22 | 32 | 41 | 49 | 58 | 78 | 96 | 115 |
| | VOLTAGE DISTORTION ALLOWED | ±15% | | | | | | | | |
| | FREQUENCY DISTORTION | ±5% | | | | | | | | |
| MODEL BL—B□20□□ | | 2003 | | 2005 | | 2007 | | 2011 | | 2015 |
| MAX MOTOR POWER (KW) | | 3.7 | | 5.5 | | 7.5 | | 11 | | 15 |
| RATED OUTPUT | RATED OUTPUT POWER (KVA) | 7 | | 10 | | 14 | | 20 | | 27 |
| | RATED OUTPUT CURRENT (A) | 17.5 | | 25 | | 33 | | 49 | | 66 |
| | MAX OUTPUT VOLTAGE (V) | 3-phase, AC380 (match the input voltage) | | | | | | | | |
| | RATED FREQUENCY (Hz) | 50 | | | | | | | | |
| | MAX OUTPUT FREQUENCY (Hz) | 120 | | | | | | | | |
| INPUT POWER | RATED VOLTAGE (V) | 3-phase AC380 | | | | | | | | |
| | RATED FREQUENCY (Hz) | 50 | | | | | | | | |
| | RATED INPUT CURRENT (A) | 21 | | 27 | | 40 | | 52 | | 68 |
| | VOLTAGE DISTORTION ALLOWED | ±15% | | | | | | | | |
| | FREQUENCY DISTORTION | ±5% | | | | | | | | |
| BASIC FEATURES | CONTROL METHOD | Simplex Collective, Duplex Collective, 3~8 units Group Control | | | | | | | | |
| | ELEVATOR SPEED RANGE | 0.5~4m/s | | | | | | | | |
| | MAX FLOOR | 64 | | | | | | | | |
| | APPLICABLE ELEVATOR | Passenger, Hospital, Panoramic, Goods, Villa Elevator | | | | | | | | |
| | APPLICABLE TRACTION MACHINE | Gear Traction Machine, Gearless Traction Machine | | | | | | | | |
| | COMMUNICATION | CAN BUS serial communication | | | | | | | | |
| | LEVELING PRECISION | ≤3mm | | | | | | | | |
| DRIVE FEATURES | CONTROL METHOD | Space vector PWM (SVPWM) Close loop vector control | | | | | | | | |
| | CARRIER FREQUENCY | 8KHz (6~15KHz Adjustable) | | | | | | | | |
| | SPEED CONTROL RANGE | 1:1000 | | | | | | | | |
| | SPEED CONTROL ACCURACY | ±0.05% (25°C±10°C) | | | | | | | | |
| | SPEED RESPONSE | 30Hz | | | | | | | | |
| | TORQUE LIMIT | Available (Parameter setting) | | | | | | | | |

TABLE 2.1 STANDARD SPECIFICATION (CONT'D)

| | | |
|----------------------|---|--|
| DRIVE FEATURES | TORQUE ACCURACY | ±5% |
| | FREQUENCY CONTROL RANGE | 0~120Hz |
| | FREQUENCY ACCURACY | Digital given: ±0.01% (-10°C~+40°C) |
| | FREQ GIVEN RESOLUTION | Digital given: 0.01Hz |
| | FREQ OUTPUT RESOLUTION | 0.01Hz |
| | OVERLOAD CAPACITY | 150% rated current 60S; 180% rated current 10S |
| | START UP TORQUE | 180% rated current 0Hz |
| | ACCEL/DECEL TIME | 0.001~600s |
| | MAIN CONTROL FUNCTION | Non-load-compensation start up; Battery-driven running; Auto-tuning; load compensation; cooling fan control; basic blocking; torque control; CAN communication reference; Normal Acc/Dec; s-curve speed; monitor of main machine for which electric current can be effectively interdict or not when the car stops; interior brake unit; PG dividing frequency output, automatic retrying after fault; automatic resetting after fault; parameter copying. |
| CONTROL INPUT/OUTPUT | OC CONTROL POWER SUPPLY | Isolated external DC24V |
| | RELAY OUTPUT POWER | Isolated external DC24V |
| | LOW VOLTAGE OC INPUT | 26 outputs, rated load: 7mA / DC24V,100HZ max |
| | HIGH VOLTAGE OC INPUT | 6 outputs, rated load: 8mA / AC110V,100HZ max |
| | PLC RELAY OUTPUT | 12 outputs, 1NO, contactor rated: 5A / 30VDC、5A / 250VAC |
| | CAN BUS | 2 ports: Duplex; group control; HOP; COP; Wireless monitoring |
| | SERIAL COM | 1 port: Hand operator |
| | RS232 COM | 2 ports: Monitor/Program |
| DISP | HAND OPERATOR | Chinese/English LCD display |
| | MONITOR INTERFACE | Display parameters, elevator running status, digital wave |
| MAIN PROTECTION | OVER CURRENT | Stop when current exceed 200% rated output current |
| | FUSE | Stop at fuse brake at main circuit |
| | OVER LOAD | Stop at 150% rated current 60S or 180% rated current 10S |
| | OVER VOLTAGE | Stops when main bus voltage over 789V (400V level) |
| | UNDER VOLTAGE | Stops when main bus voltage is lower than 380V (400V level) |
| | HEAT SINK OVER TEMPERATURE | Via electric heat sensor |
| | IPM INNER PROTECTION | IPM OC; overheat; short circuit; under voltage protection |
| | MOTOR PROTECTION | Protects through electric heat sensor |
| | IMPACT RESTRAINING CIRCUIT | Protects through contactor feedback signal |
| | OVER SPEED | Protects while motor speed is exceeding the max set value |
| | SPEED DEVIATION | Protects while speed deviation is over setting value |
| | PG FAULT | Protects while PG disconnect or phase error |
| | AUTO-TUNING FAULT | Protects while a fault generates during motor auto-tuning. |
| | PHASE LOST | Protects while input/output power loose phase |
| | DOOR INTERLOCK FAULT | Protects while door interlock circuit breaks during elevator operation |
| | SAFETY CIRCUIT FAULT | Protects while safety circuit breaks during elevator operation |
| | BRAKE CIRCUIT FAULT | Protects when output brake signal but receive no feedback |
| LEVELING ZONE FAULT | Protects when leveling zone signal is wrong | |

TABLE 2.1 STANDARD SPECIFICATION (CONT'D)

| | | |
|-----------------|-------------------------|---|
| MAIN PROTECTION | OUTPUT CONTACTOR ERROR | Protects when output contactor does not work properly |
| | RUNNING TIME LIMIT | Protects when run time over setting value for one trip |
| | FLOOR COUNTING ERROR | Protects when floor counting is wrong |
| | COMM. INTERFERENCE | Protects when communication error due to interference |
| | HOISTWAY LEARNING ERROR | Protects when hoistway learning fails |
| MODE | PROTECTION CLASS | C: Closed type IP20; O: Open type IP00 |
| | COOLING METHOD | Forced air cooling |
| | INSTALLATION | Wall mounting (inside cabinet) |
| ENVIRONMENT | AMBIENT TEMPERATURE | -10°C ~ +40°C |
| | HUMIDITY | 5~95%RH, non-condensing |
| | STORAGE TEMPERATURE | -20°C ~ +60°C |
| | LOCATION | In doors, without direct sunlight, dust, corrosive/explosive gases, oil fog, vapor, water dripping, or salty substances |
| | ALTITUDE | <1000M |
| | VIBRATION | 10~20Hz, <9.8m/S ² ; 20~50Hz, <2m/S ² |

2.4. Product Appearance

BL3—U series elevator drive has open type and close type and the open type has wall-mounted installation and inserted installation type.

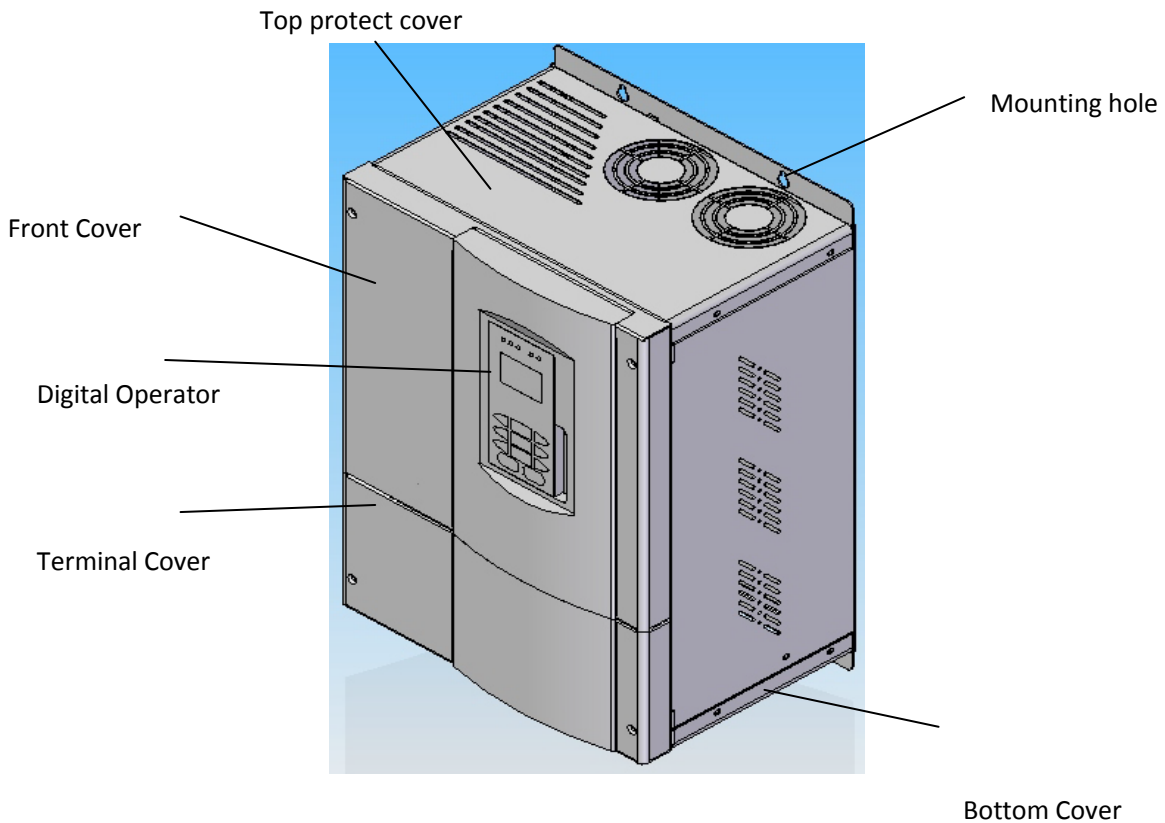

FIGURE 2.3 CLOSED TYPE

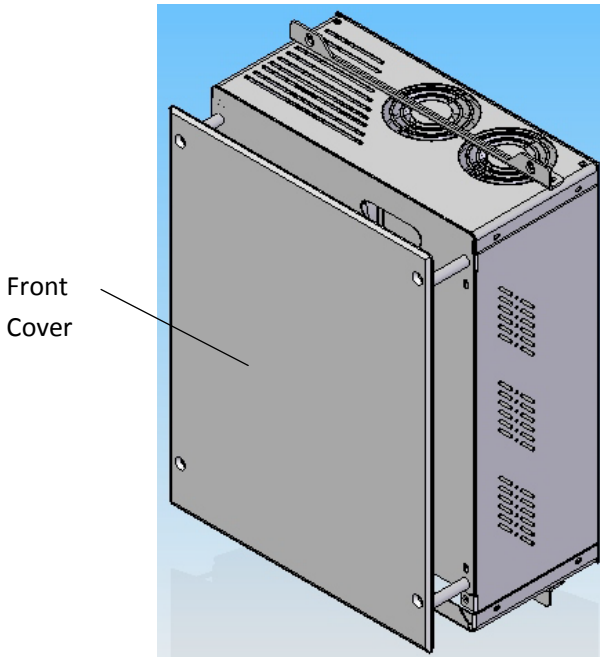

FIGURE 2.4 OPEN TYPE INSERTED INSTALL

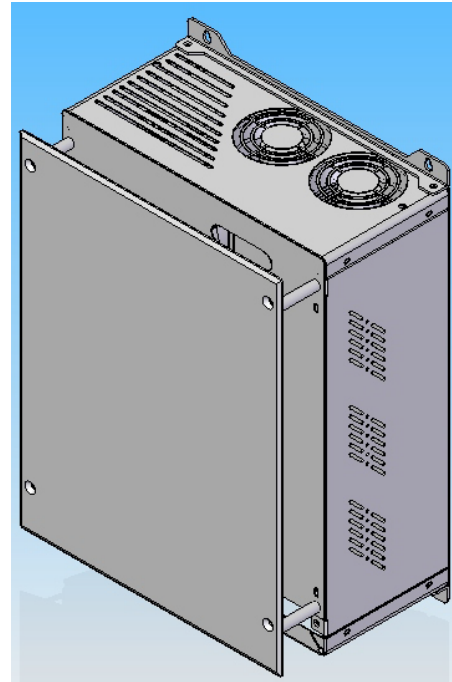

FIGURE 2.3 OPEN TYPE WALL-MOUNT

2.5. Exterior Dimension

BL3—U series elevator drive has open type and close type and the open type has wall-mounted installation and inserted installation type.

2.5.1. Open Type Inverters

2.5.1.1 OPEN TYPE WALL MOUNTED

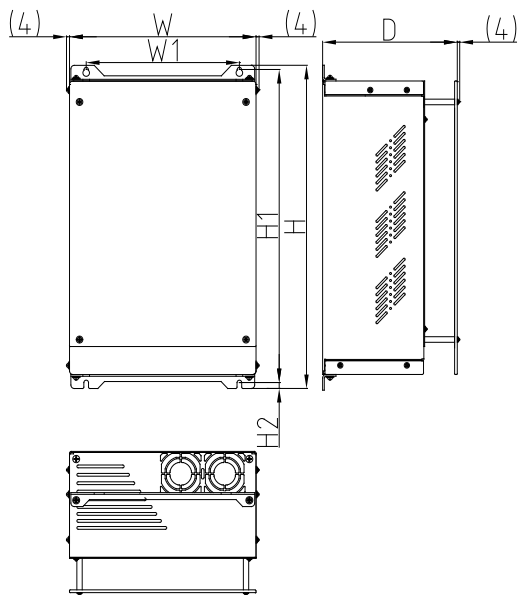

FIGURE 2.6 OPEN TYPE WALL-MOUNT DIMENSION

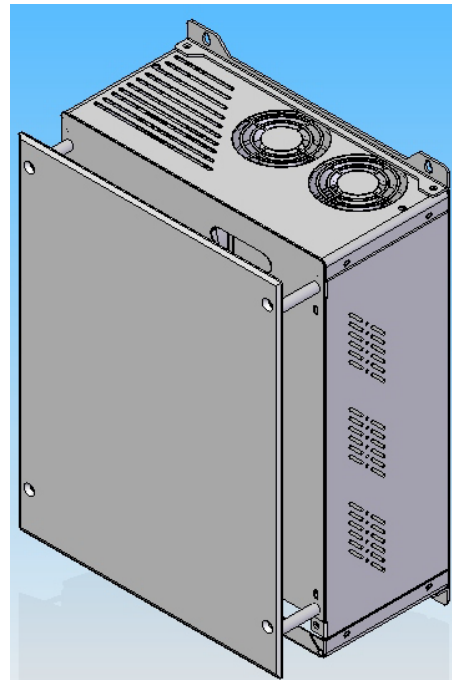

FIGURE 2.7 EXTERIOR DIAGRAMS

2.5.1.2 OPEN TYPE INSERTED

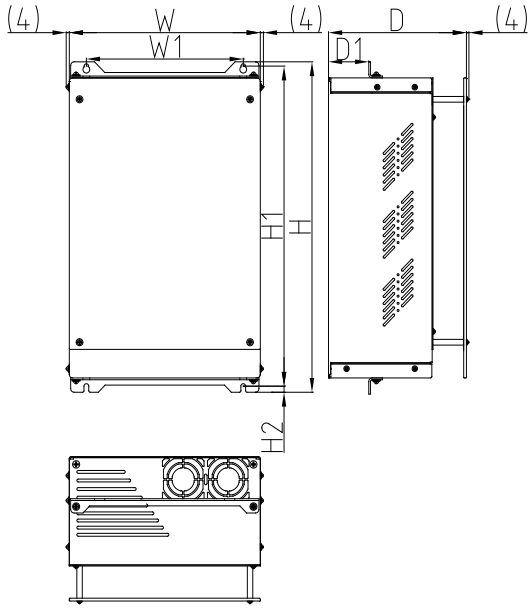

FIGURE 2.8 OPEN TYPE INSERTED DIMENSION

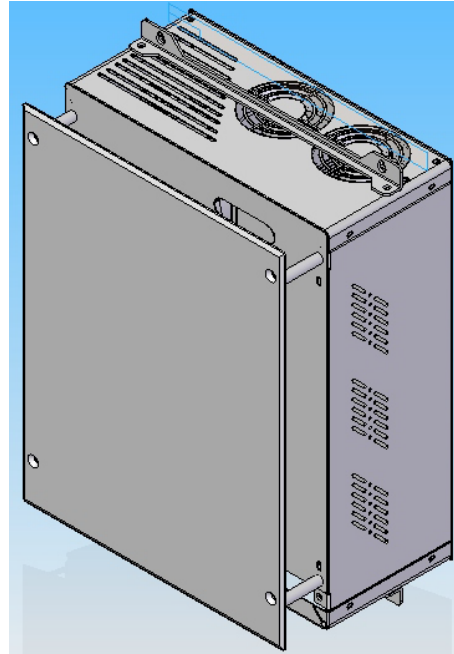

FIGURE 2.9 OPEN TYPE INSERTED EXTERIOR

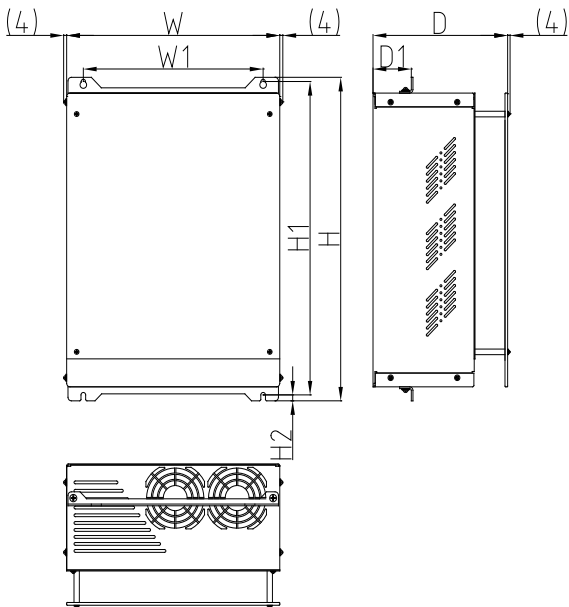

FIGURE 2.10 OPEN TYPE INSERTED DIMENSION

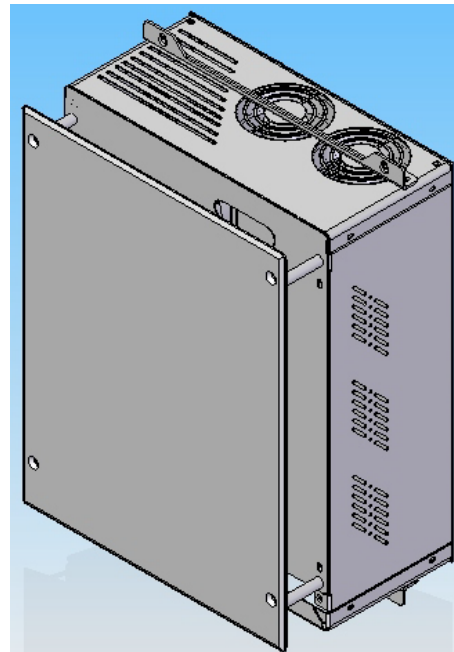

FIGURE 2.11 OPEN TYPE INSERTED EXTERIOR

TABLE 2.2 OPEN TYPE INVERTER EXTERIOR DIMENSION

| Voltage | Installation | Max Motor Power (KW) | Inverter Model | Figure | Exterior Dimension | | | | | | Weight kg | | |
|--------------|--------------|----------------------|----------------|-------------|--------------------|-----|-----|-----|-----|-----|-----------|------|----|
| | | | | | W | H | D | W1 | H1 | H2 | | D1 | |
| 400V 3-phase | Wall-Mounted | 5.5 | BL3-BO4005 | Figure 2.6 | 260 | 373 | 203 | 200 | 358 | 8.5 | 0 | 16 | |
| | | 7.5 | BL3-BO4007 | | | | | | | | | 16 | |
| | | 11 | BL3-BO4011 | | | | | | | | | 16 | |
| | | 15 | BL3-BO4015 | | 16 | | | | | | | | |
| | | 18.5 | BL3-BO4018 | | 18 | | | | | | | | |
| | | 22 | BL3-BO4022 | | 18 | | | | | | | | |
| | | 30 | BL3-BO4030 | | 20 | | | | | | | | |
| | | 37 | BL3-BO4037 | | 35 | | | | | | | | |
| | | 45 | BL3-BO4045 | | 35 | | | | | | | | |
| | Inserted | 5.5 | BL3-BO4005 | Figure 2.8 | 260 | 373 | 203 | 200 | 358 | 8.5 | 57.5 | 16 | |
| | | 7.5 | BL3-BO4007 | | | | | | | | | 16 | |
| | | 11 | BL3-BO4011 | | | | | | | | | 16 | |
| | | 15 | BL3-BO4015 | | 16 | | | | | | | | |
| | | 18.5 | BL3-BO4018 | | 18 | | | | | | | | |
| | | 22 | BL3-BO4022 | | 18 | | | | | | | | |
| | | 30 | BL3-BO4030 | | 20 | | | | | | | | |
| | | 37 | BL3-BO4037 | | 35 | | | | | | | | |
| | | 45 | BL3-BO4045 | | 35 | | | | | | | | |
| 200V 3-phase | Wall-Mounted | 3.7 | BL3-BO2003 | Figure 2.6 | 260 | 373 | 203 | 200 | 358 | 8.5 | 0 | 16 | |
| | | 5.5 | BL3-BO2005 | | | | | | | | | 16 | |
| | | 7.5 | BL3-BO2007 | | | | | | | | | 16 | |
| | | 11 | BL3-BO2011 | | 18 | | | | | | | | |
| | | 15 | BL3-BO2015 | | 18 | | | | | | | | |
| | Inserted | 3.7 | BL3-BO2003 | Figure 2.8 | 260 | 373 | 203 | 200 | 358 | | 8.5 | 57.5 | 16 |
| | | 5.5 | BL3-BO2005 | | | | | | | | | | 16 |
| | | 7.5 | BL3-BO2007 | | | | | | | | | | 16 |
| | | 11 | BL3-BO2011 | Figure 2.10 | 320 | 463 | 203 | 270 | 448 | | | 59 | 18 |
| | | 15 | BL3-BO2015 | | | | | | | | | | 18 |
| | | 3.7 | BL3-BO2003 | Figure 2.10 | 320 | 463 | 203 | 270 | 448 | | | 59 | 18 |
| | | 5.5 | BL3-BO2005 | | | | | | | | | | 18 |
| | | 7.5 | BL3-BO2007 | | | | | | | | | | 18 |
| | | 11 | BL3-BO2011 | | | | | | | | | | 18 |
| | | 15 | BL3-BO2015 | | | | | | | | | | 18 |

2.5.2. Close Type

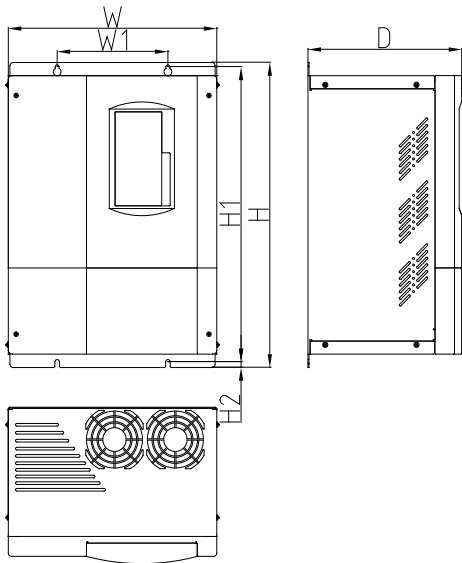

FIGURE 2.12 CLOSE TYPE DIMENSION

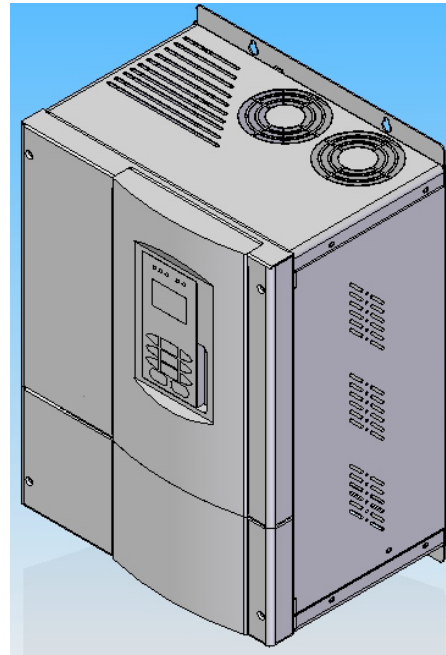

FIGURE 2.13 CLOSE TYPE EXTERIOR DIAGRAM

TABLE 2.3 CLOSE TYPE INVERTER EXTERIOR DIMENSION

| Voltage | Max Motor Power (KW) | Inverter Model | Exterior Dimension | | | | | | Weight kg |
|--------------|----------------------|----------------|--------------------|-----|-----|-----|-----|-----|-----------|
| | | | W | H | D | W1 | H1 | H2 | |
| 400V 3-phase | 5.5 | BL3-BC4005 | 280 | 460 | 236 | 130 | 445 | 8.5 | 16 |
| | 7.5 | BL3-BC4007 | | | | | | | 16 |
| | 11 | BL3-BC4011 | | | | 16 | | | |
| | 15 | BL3-BC4015 | | | | 16 | | | |
| | 18.5 | BL3-BC4018 | 320 | 270 | 170 | 18 | | | |
| | 22 | BL3-BC4022 | | | | 18 | | | |
| | 30 | BL3-BC4030 | | | | 20 | | | |
| | 37 | BL3-BC4037 | 390 | 650 | 300 | 340 | 600 | 35 | |
| | 45 | BL3-BC4045 | 390 | 650 | 300 | 340 | 600 | 35 | |
| 200V 3-phase | 3.7 | BL3-BC2003 | 280 | 460 | 236 | 130 | 445 | 8.5 | 16 |
| | 5.5 | BL3-BC2005 | | | | | | | 16 |
| | 7.5 | BL3-BC2007 | | | | 16 | | | |
| | 11 | BL3-BC2011 | 320 | 170 | 170 | 18 | | | |
| | 15 | BL3-BC2015 | | | | 18 | | | |

2.6. Confirmation upon Delivery

Check below items when receiving the products.

TABLE 2.4 THINGS TO CHECK UPON DELIVERY

| NOTES | METHOD |
|---|--|
| Has the correct model of inverter been delivered? | Check the model number on the nameplate. |
| Inverter damaged in any way? | Check exterior for any damaged caused by shipment. |
| Any screws or other components loose? | Use a screwdriver to check for tightness. |
| Open terminal cover, control board loose? | Use a screwdriver to check for tightness. |

- ◇ If find any irregularities in the above notes, contact the local agencies immediately.

2.7. Installation

2.7.1. Installation Site

Install the inverter in an environment which meets the condition described in table 2.5

Table 2.5 Environment requirement on installation

| Type | Installation Method | Ambient Temperature | Ambient Humidity |
|-------|---------------------|---------------------------------------|---------------------------|
| Open | Wall-mounted/Insert | -10 ⁰ C~+45 ⁰ C | 5~95%RH (No condensation) |
| Close | Wall-mounted | -10 ⁰ C~+40 ⁰ C | 5~95%RH (No condensation) |

Take care and confirm the following items while installing

1. Install the Inverter in a clean location which is free from oil mist and dust, or it can be installed in a fully closed control panel which is completely shielded from floating dust.
2. When installing or operating the Inverter, always take special care so that metal powder, oil, water, or other foreign matter does not get into the Inverter.
3. Do not install the Inverter on combustible material, such as wood.
4. Install the Inverter in a location free from radioactive materials and combustible materials.
5. Install the Inverter in a location free from harmful gas and liquid.
6. Install the Inverter in a location without excessive vibration.
7. Install the Inverter in a location free from chlorides.
8. Install the Inverter in a location without direct sunlight.

2.7.2. Temperature Requirement

To enhance the reliability, the Inverter should be installed in an environment free from extreme temperature increasing. If the Inverter is installed in a closed environment, such as a cabinet, use a cooling fan or air conditioner to maintain the internal air temperature below 45⁰C.

2.7.3. Protect the inverter from Foreign Object

Place a cover over the Inverter during installation to shield it from metal powder produced by drilling. Always remove the cover from the Inverter after the completion of the installation. Otherwise, ventilation will be reduced, causing the Inverter to overheat

2.7.4. Removing and attaching the Terminal Cover

Follow figure 2.14—2.15. Note the open type BL3-B integrated controller terminal cover and front cover are the same.

◆ REMOVE TERMINAL COVER

Release the screw at the terminal cover, open the cover based on arrow direction to release the cover for wiring.

◆ INSTALL FRONT COVER

After all the wiring procedures, follow the opposite method of removing terminal cover to tighten the front cover.

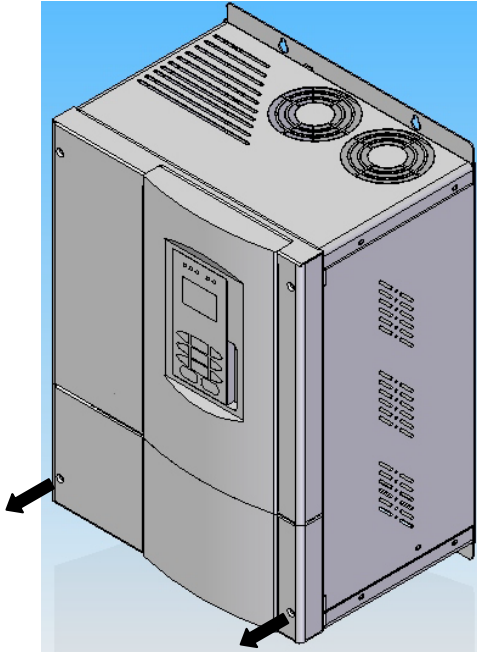

Figure 2.14 Remove terminal cover on close type

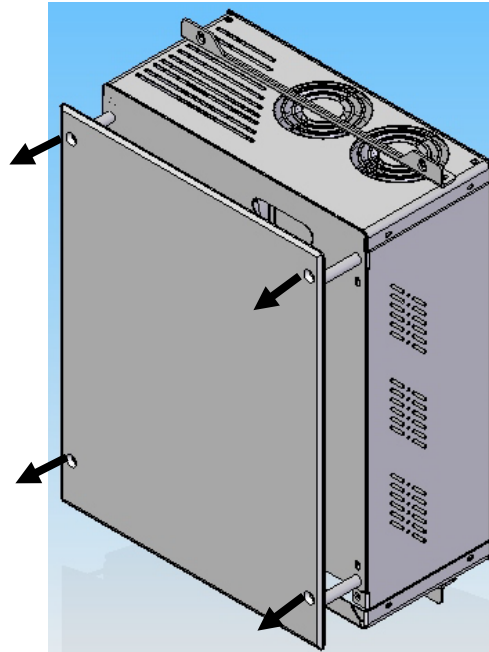

Figure 2.15 Remove Terminal cover on open type

2.7.5. Remove/Attach Hand operator

Follow Figure 2.16.

◆ Remove the hand operator

Push side of hand operator on arrow 1 to unlock the operator from the front cover, pull the operator up on the direction of arrow 2.

◆ Install Hand operator

Opposite with remove procedures

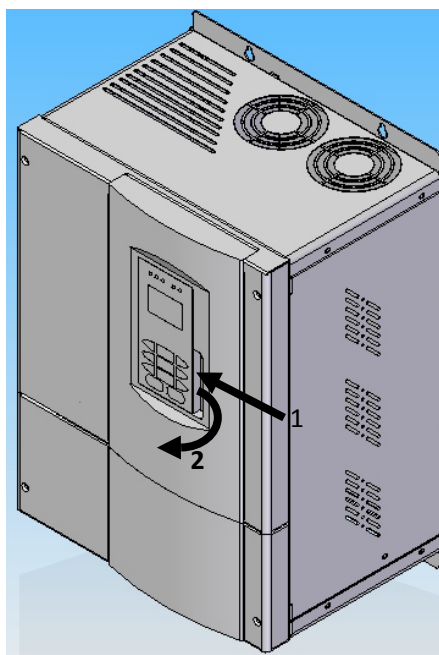

Figure2.16 Removing Digital Operator

2.7.6. Installation Orientation and Space

Install the Inverter vertically so as not to reduce the cooling effect. When installing the Inverter, always provide the following installation space to allow normal heat dissipation.◦

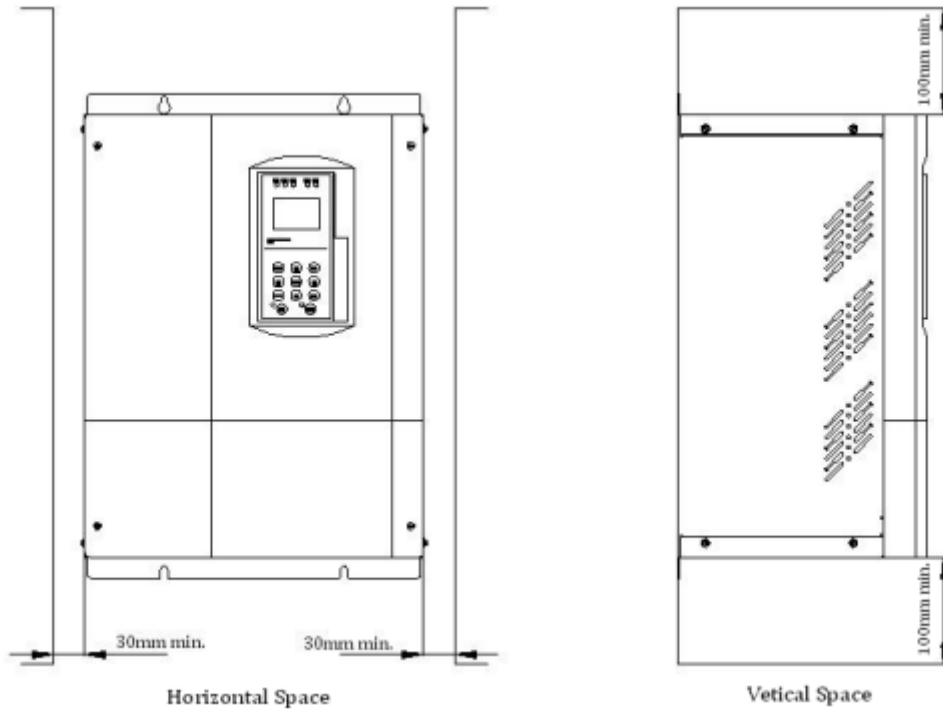

Figure 2.17 Driver Installation Orientations and Space



1. The same space is required horizontally and vertically for both open type and close type wall-fixed inverter.
2. Always remove the protection covers before installing inverter with an output terminal in a panel.
I. Always provide enough space for suspension bolts and the main circuit lines when installing inverter with an output terminal in a panel.

2.8. Equip Brake Resistor

Elevator is a typically potential energy load type device. When the elevator is at brake mode, the electricity feedback of motor brake will make the DC bus voltage increase. Energy can release by allocate suitable brake component. If not, over-voltage protection will be activated. BL3-B series elevator controller has internal brake unit, so customers only need to equip suitable brake resistance. Allocation resistance varies with the value of drive power.

The detailed specification of brake resistance refers to table 2.6.

Table 2.6 Braking Resistor value list

| Model | Motor Power (kW) | Braking Resistor value for Synchronous Machine (Ω/W) | Braking Resistor value for Induction Machine (Ω/W) |
|------------|------------------|---|---|
| BL3-B□4005 | 5.5 | 75 Ω /2000W | 75 Ω /1000W |
| BL3-B□4007 | 7.5 | 65 Ω /2500W | 65 Ω /1000W |
| BL3-B□4011 | 11 | 40 Ω /3500W | 40 Ω /2000W |
| BL3-B□4015 | 15 | 30 Ω / 6000W | 30 Ω / 4000W |
| BL3-B□4018 | 18.5 | 25 Ω /6000W | 25 Ω /4000W |
| BL3-B□4022 | 22 | 20 Ω /9000W | 20 Ω /6000W |
| BL3-B□4030 | 30 | 16 Ω /11000W | 16 Ω /8000W |
| BL3-B□4037 | 37 | 12 Ω /15000W | 12 Ω /15000W |
| BL3-B□4045 | 45 | 10 Ω /15000W | 10 Ω /15000W |
| BL3-B□2003 | 3.7 | 30 Ω / 2000W | 30 Ω / 2000W |
| BL3-B□2005 | 5.5 | 24 Ω / 2000W | 24 Ω / 2000W |
| BL3-B□2007 | 7.5 | 20 Ω / 4000W | 20 Ω / 2000W |
| BL3-B□2011 | 11 | 12 Ω / 4000W | 12 Ω / 4000W |
| BL3-B□2015 | 15 | 10 Ω / 6000W | 10 Ω / 4000W |

2.9. Product Function

Table 2.7 Basic Function List

| No. | Name | Purpose | Description | Note |
|-----|---------------------------------------|---|--|---|
| 1 | Automatic Run | | 1.Door auto open at stop; 2.Door auto close in delay time; 3.Door close at close button pushed; 4.Car call register, auto cancel wrong call; 5.Landing call stop car in same direction 6. Car service opposite direction landing call at top/bottom floor | 1. Turn all inspection switch to normal state; 2. Turn Auto/Attendant switch to Auto state; 3. The other two Auto/Inspection switch at Auto state; |
| 2 | Attendant Run | | 1.Door auto open at stop; 2.Door close at close button pushed; 3.Car call auto register/cancel wrong call; 4.Landing call stop car in same direction; | 1. Turn all inspection switch to normal state; 2. Turn Auto/Attendant switch to Attendant state; 3. The other two Auto/Inspection switch at Auto state; |
| 3 | Inspection Run | Used at System Commissioning; Maintenance | When push up/down button in inspection mode, car runs up/down at inspection speed. Car stop once button released. | Auto/Inspection switch at car top, car and control cabinet, priority from high to low. |
| 4 | Auto door open at power on | Auto door open | If car at leveling zone at power on, door open automatically. | |
| 5 | Auto door close in delay time | Door keep opening | After door complete opened, it keep open and will auto close after delay time. | 1.Delay time is set through open door holding time parameter (T) 2.T-2s with only landing call 3.T+2s with both landing call and car call. |
| 6 | Door OP at current floor landing call | Door open for landing call | If landing call on the same floor at door closing or door closed but car not running, door will open automatically. | Delay time is set by open door holding time. |
| 7 | Safety Plate/light curtain | Close door safely | If safety plate touched/light curtain covered, door will open and close again. | Door safety plate/light curtain reset, door automatically close again. |
| 8 | Overload door keep open | Wait for load reduction | Door open at overload, with overload light on, buzzer sounds, CZ display on COP. Car not running. | Elevator back to normal state when overload is cleared. |
| 9 | Full-load drive by pass | Run to nearest registered floor | At full load, car only respond to car call, not to landing call. | Elevator back to normal state when overload is cleared. |
| 10 | Attendant control by pass | VIP Run | At attendant run, press pass over button, elevator only responds to car call. | |
| 11 | Operation mode display | Adjust/Maintenance | Elevator Running mode, direction, floor, door mode, load and fault information display on integrated controller LCD. | |

Table 2.7 Basic Function List (Cont'd)

| No. | Name | Purpose | Description | Note |
|-----|-----------------------------|-----------------|---|---|
| 12 | Auto control light | Energy Saving | Car box light turned off if elevator is not used for 15minutes. Turned on after receiving any call. | |
| 13 | Fire-Service Mode | | <p>System enters fire-service mode when fire switch is closed:</p> <ol style="list-style-type: none"> 1.Clears up all landing/car call; 2.Auto return to fire floor 3.Door keep opens 4. Output fire linkage signal after return to fire floor. 5.If elevator runs in opposite direction, stop at nearest floor, do not open door, run directly to fire floor, door keep opens. | <p>Two fire-service modes for option:</p> <p>Fire mode 1: Elevator stop running after returning to fire floor.</p> <p>Fire mode 0:</p> <ol style="list-style-type: none"> a. Landing call disabled; b. Door keep opens at fire floor; c. To run elevator, fireman should first choose the target floor, press and hold the close door button till door close, elevator run; if close door button is released before door closed, door open again. d. Arriving target floor, press and hold open door button till door opens, otherwise door close again. e. Can only set one floor every running. |
| 14 | Auto stop at elevator fault | Free passengers | When car stop outside landing zone at elevator fault, it will auto crawl to leveling zone in middle floor direction and open door. | Only if safety circuit and inverter are both working normal. |
| 15 | Parking | Stop Running | <p>Elevator enters parking mode at electric lock closed.</p> <ol style="list-style-type: none"> 1. Elevator does not respond to landing call, service all car call and return to parking floor (adjustable); 2. If no car call, elevator directly return to parking floor; 3. After return to parking floor: <ol style="list-style-type: none"> a. HOP and COP display parking sign "ZT"; b. Do not respond to car/landing call; c. After 10s, door close, car box light and HOP/COP display turn off. d. Press any COP/Open, close door button, car box light turn on; e. Press Open/Close door button, car door close again and cut car box light after 10s. | <ol style="list-style-type: none"> 1. If elevator at inspection mode when close electric lock, car cannot auto return to parking floor. Other functions remain. 2. Integrated controller in working state when elevator at parking mode. Once open electric lock, elevator will run normally. |

Table 2.7 Basic Function List (Cont'd)

| No. | Name | Purpose | Description | Note |
|-----|----------------|--------------------------------|---|---|
| 16 | Duplex Control | Two elevator optimized control | <p>1. At landing call, both elevator answers based on their running state and location, and only one elevator respond to increase the running frequency.</p> <p>2. When both elevators at waiting state, one return to waiting floor (normally G floor), the other one stays at current location.</p> | To achieve duplex, connect two integrated controllers with the cable provided and set duplex parameter accordingly. |
| 17 | Group Control | Multi-Elevator | Control up to 8 elevators together | |

Table 2.8 Special Function List

| No. | Name | Purpose | Description | Note |
|-----|------------------------------------|-------------------------------|--|--|
| 1 | Hoistway Learning | Measure, store hoistway data. | In inspection mode, from bottom terminal switch to top terminal switch , measure and store the landing zone and hoistway switch position. | <p>Hoistway learning may be terminated in unusual condition and system will give error code accordingly. Please follow Table 8.2 for detail error codes.</p> <p>▲ Note: When hoistway learning stops, only when “Success” is displayed on the operator means hoistway learning success.</p> |
| 2 | Double press Cancellation | Cancel car call | Press car call button again could cancel such call. (Button answer light off) | Such function is also achievable when elevator is not running. |
| 3 | Anti-mischief | Cancel car call at terminal | <p>1. When elevator reaches terminal switch, clear all car call.</p> <p>2. For elevator with weighing device, only last 3 car calls are registered at light load.</p> | |
| 4 | Landing call button stuck diagnose | Repair indication | If one landing call button is pressed for more than 20s, it is considered stuck (cannot reset), such call is not registered, button answer light flashes. | Exit such state when button is reset. |
| 5 | Repeat close door | | At close door command, if door interlock circuit not connected in set time, door open and close again. | If repeat 5 times and door interlock circuit still not close, elevator stops for service, display error code accordingly. |
| 6 | Machine room floor selection | Maintenance | Use hand operator to input car call | |
| 7 | Machine room floor open/close door | Maintenance | Use hand operator to input open/close door command | |

Table 2.8 Special Function List (Cont'd)

| No. | Name | Purpose | Description | Note |
|-----|----------------------------------|---------------------------------------|--|--|
| 8 | Non-Stop Floor | | User can set any floor not to stop | |
| 9 | Homing floor set | Wait at homing floor | In auto mode, with no landing/car call for certain time, car goes to homing floor. | Can only set one homing floor. |
| 10 | Display character set | Change display of certain floor | Display character on any floor can be set through hand operator. (Character or figure) | |
| 11 | Attendant Direction Set | VIP Mode | Choose elevator direction through up/down button before running | Only available in Attendant mode. |
| 12 | Auto Start/Stop Elevator Service | Automatic start/stop elevator service | User may set elevator on/off time by practical requirement. | <ol style="list-style-type: none"> 1. Time is set by 24hrs 2. Cancel this function by setting both on/off time to 00. 3. This function is only available with electric lock open, otherwise elevator in parking mode. 4. To enable elevator service in off time: <ol style="list-style-type: none"> a. Close electric lock, wait for 1s, reopen electric lock to enter force on mode, elevator could use normally. b. Close electric lock after use, wait for 1s, reopen electric lock to exit force on mode, elevator in off time. |
| 13 | Special Running | Special Passenger Service | Landing call is invalid, elevator controlled by attendant. Door control mode is attendant mode. | Only available with special buttons. |
| 14 | Door open time delay set | Delay the door open time | Press this button before car door fully closed, door open time will be delayed to set time. | <ol style="list-style-type: none"> 1. Must have door open delay button 2. Only available in Auto Mode 3. Normally used in bed elevator system |
| 15 | Rear door control | Elevator with two door | Control rear door operation on each floor | Follow section 6.8 for rear door mode setting. |
| 16 | Trouble Shooting | Automatic find and record fault data. | <ol style="list-style-type: none"> 1. When fault happens, system diagnoses fault condition and display error code on LCD. 2. System record the last 30 fault data (fault time/class/floor) in error report menu for further reference. | For trouble shooting error code please follow Table 8.1 Trouble shooting for Elevator |

Table 2.8 Special Function List (Cont'd)

| No. | Name | Purpose | Description | Note |
|-----|-------------------------|--|--|--|
| 17 | Interference evaluation | Inspect site interference condition | Evaluate the site shielding condition, including control cabinet/hoistway connection to ground, help to increase resistance to interference. | This function is only available after elevator commissioning and testing. |
| 18 | Encoder Evaluation | Inspect encoder output signal | Analyze the evaluate encoder output signal, help service team on site maintenance to eliminate elevator shock and leveling issue. | Provide direct evidence on encoder quality and interference condition. |
| 19 | Input port evaluation | Inspect input signal interference | System evaluates and display the input signal quality, help service team to increase the hoistway cable resistance to interference and eliminate elevator COP/HOP display fault information and leveling issue. | Provide direct evidence on input signal interference. |
| 20 | Emergency Auto Leveling | After power cut, elevator powered by emergency leveling device, level to the closest landing zone. | <p>After power cut, elevator powered by emergency leveling device and level to the closest landing zone to free the passenger. Such function must satisfy certain conditions:</p> <ol style="list-style-type: none"> 1. After power cut, elevator powered by emergency leveling device. (integrated controller I/O board terminal X18 enable); 2. Elevator NOT in inspection mode; 3. Elevator NOT at landing zone; 4. Elevator can run normally; 5. Safety/Door inter-lock circuit close; <p>Elevator emergency leveling procedures when not at landing zone:</p> <ol style="list-style-type: none"> 1. Determine run direction based on load condition (need weighing device); 2. After leveling to the closest floor, door keep open, emergency leveling device cut power after certain time. 3. After power recovery, if system record a history of emergency leveling action, elevator return to bottom floor to re-calibrate hoistway data. <p>When at landing zone, emergency leveling device supply power, elevator door open (integrated controller I/O board terminal X18 must enable).</p> | <p>Because the power of emergency automatic leveling running is supplied by elevator emergency automatic leveling controller device, drawings of controller system is different from standard drawing. When you need this function, please ask technique department for drawings accordingly.</p> <p>Use SYT-YY series elevator emergency automatic leveling controller of our company, reference to: <use description of 11.6—STJ-YY series elevator emergency automatic leveling controller>.</p> |

Table 2.8 Special Function List (Cont'd)

| No. | Name | Purpose | Description | Note |
|-----|--------------------------|--|---|--|
| 21 | Elevator for handicapped | Special COP/HOP for handicapped | <ol style="list-style-type: none"> 1. start elevator for handicapped function through parameter setting; 2. COP: Car call function & door open/close button. 3. HOP: Recognize for handicapped calling through different floor; 4. Principle: When leveling, opening time will keep longer if handicapped is on this floor (the opening time can be changed); When press cop opening button, opening time will keep longer. | <p>◆ Set HOP address: When use elevator for the handicapped (FU14=ON) , HOP set as below: 1~32 for normal floor, 1 for bottom floor, 2 for second floor, with total 32 floors. 33~64 for handicapped floor. 33 for bottom floor, 34 for second floor, up to 64, with total 32 floors. If building has only one HOP button, the other address keep empty.</p> <p>◆ Link Car call button: 1~N floor internal select button link to car box 1~N floor internal select joint as normal internal select. N+1~N+N as handicapped cop 1~N floor internal select. COP Door open 2、 Door close 2 input as handicapped door control input (Caution: Elevator for the handicapped cannot use together with rear door function.)</p> |
| 22 | Door open in advance | When run at low speed, door open beforehand to improve running efficiency. | <p>Elevator reduce speed when approaching target landing zone, if elevator meets the condition below, door open in advance:</p> <ol style="list-style-type: none"> 1. Elevator run normally, reaching target landing zone; 2. Two leveling sensors enable; 3. Car speed lower than the set protection speed; 4. Controller low speed output enable; 5. Safety board output enable; | <p>In special function select parameter FU20=ON to enable opening in advance; For opening in advance/re-leveling function principle/wiring diagram please see Appendix 2- opening in advance /re-leveling function description.</p> |
| 23 | Re-leveling Function | To achieve re-leveling | <p>Elevator stops at one floor, when passengers move in/out, steel rope will have elastic deformation, and car may move out of landing zone. This function enables elevator move in low speed back to leveling zone with door open. Condition of re-leveling:</p> <ol style="list-style-type: none"> 1. Elevator stops and leave landing zone; 2. Two leveling sensors enable; 3. Elevator speed slower than set value; 4. Controller low speed output enable; 5. Safety electric board output enable; | <p>In special function select parameter FU19=ON to enable re-leveling function; For opening in advance/re-leveling function principle/wiring diagram please see Appendix 2- opening in advance /re-leveling function description.</p> |

Table 2.9 Main safety protection Function

| No. | Name | Elevator Description |
|-----|---|---|
| 1 | Safety Circuit | Safety circuit open, entire system stops immediately. |
| 2 | Door interlock | Elevator can only run with all door interlock closed, otherwise entire system stops immediately. |
| 3 | Operation Contactor | System check operation contactor constantly, if found any abnormality, system stop immediately. |
| 4 | Brake checking protection | The detection switch of brake arm makes a real-time inspection of opening/closing of the brake. If the brake fails to open as per requirements, the system will prevent the elevator from start. |
| 5 | Terminal speed-change & correct floor display | If the elevator detects a terminal switch during running, it will be forced to decelerate and meanwhile automatically correct the floor display. |
| 6 | Position-limit protection | If the elevator detects a limit switch, the entire system stops immediately. |
| 7 | Limit protection | If the elevator runs to trigger a limit switch, the entire system stops immediately.. |
| 8 | Instantaneous over-current protection | If detects over 200% rated output current system stops immediately. |
| 9 | Fuse blowing protection | When fuse blow, the entire system stops immediately. |
| 10 | Overload protection | If detects over 150%/180% rated current, system will stop after 60s/10S. |
| 11 | Over-voltage protection | Main DC bus voltage higher than 780V, system stop (400V) |
| 12 | Under-voltage protection | Main DC bus voltage lower than 380V, system stop (400V) |
| 13 | Radiator overheated protection | Thermal resistor protection |
| 14 | IPM interior protection | IPM over current、overheated、short circuit、under-voltage protection |
| 15 | Electric motor protection | Electric thermal protection |
| 16 | Impact restrain loop failure protection | Through contactor joint to feedback protection |
| 17 | Over speed protection | Protect when the speed is faster than allowed |
| 18 | Over deviation protection | Protect when speed deviation is larger than allowed. |
| 19 | PG fault protection | Protect when PG braking or phase stagger. |
| 20 | Self-study protection | Protect when self-study of motor parameter unusual. |
| 21 | Phase lack protection | Protect when lack of in/output phase |
| 22 | Door drive signal | Protect when door signal unusual. |
| 23 | Running time protection | Protect when once run time is longer than limited time. |
| 24 | Counter of floor protection | Protect when floor counter is wrong. |
| 25 | Trouble of communication immunity | Protect when communicate interrupt. |
| 26 | Hoistway learning error | Protect when have trouble in hoistway learning |

Table 2.10 Optional Function List

| No. | Name | Elevator Description |
|-----|-------------------|---|
| 1 | Remote Monitoring | Monitor elevator running status in monitor current through wire/wireless network; |
| 2 | Arrival Gong | Clock announce; |
| 3 | Voice Synthesizer | Voice announce; |
| 4 | Identity Control | ID/IC Car control; |
| 5 | Weighing device | Weighing device for elevator; |

Chapter 3: Wiring

This chapter explains the terminals and wiring specifications for main circuit, control circuit and PG card of integrated controller.

3.1. Connection Diagram for Elevator Integrated Controller

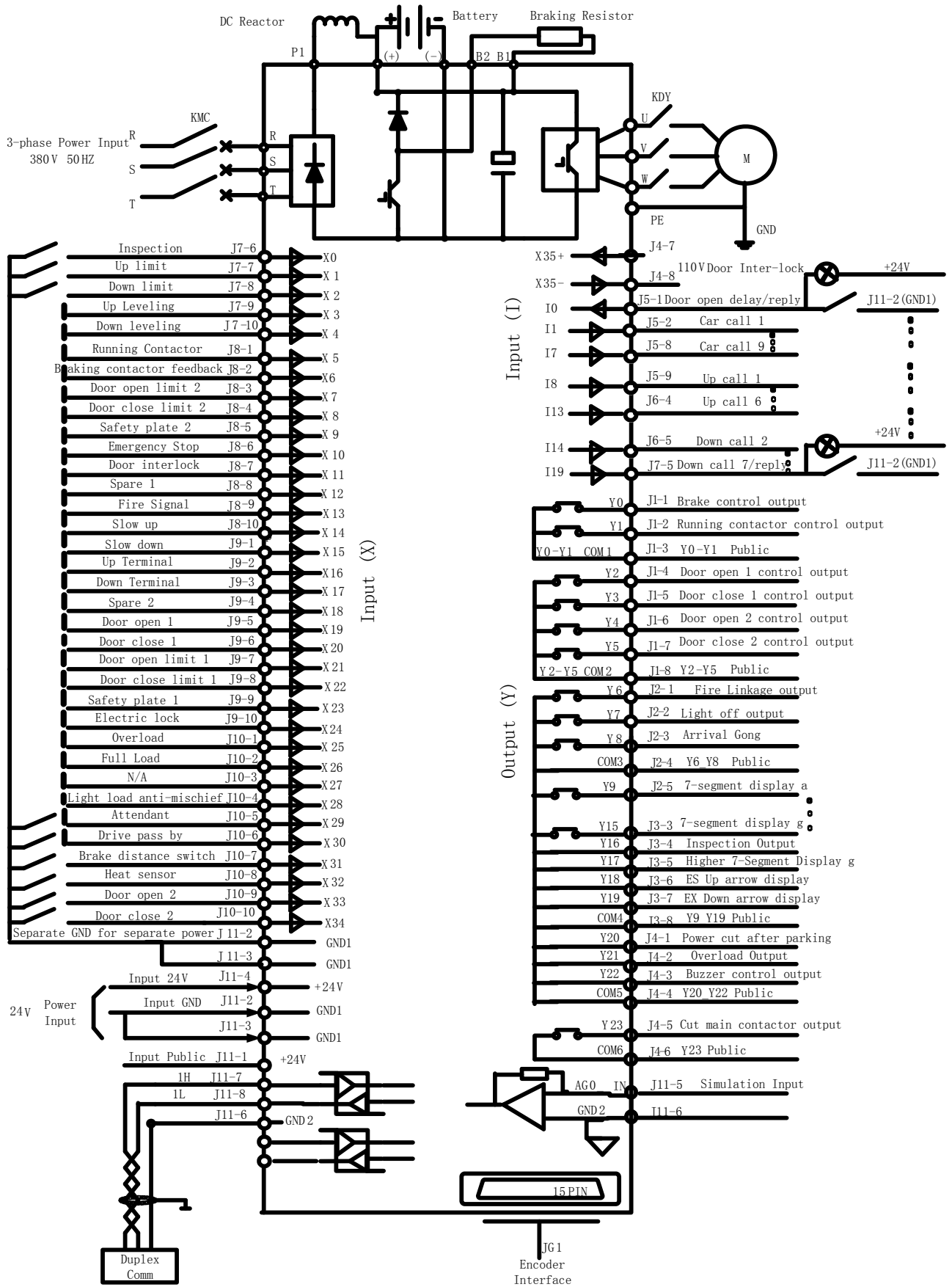

Figure 3.1 Connection Diagram for Elevator integrated controller

3.2. Wiring Main circuit Terminals

3.2.1. Main circuit structure

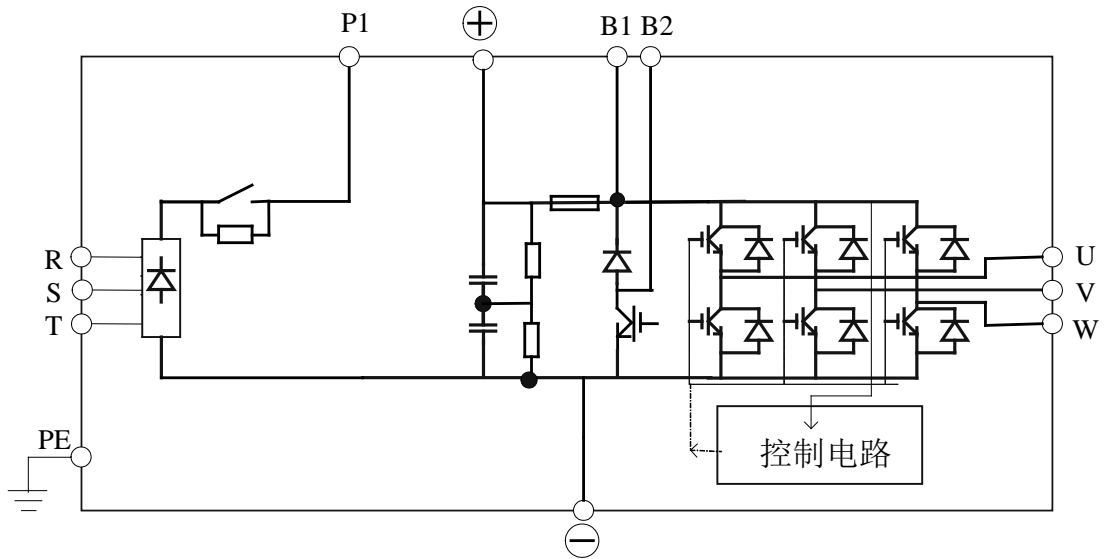

Figure 3.2 Main circuit Structure

3.2.2. Terminal arrangement for Main circuit

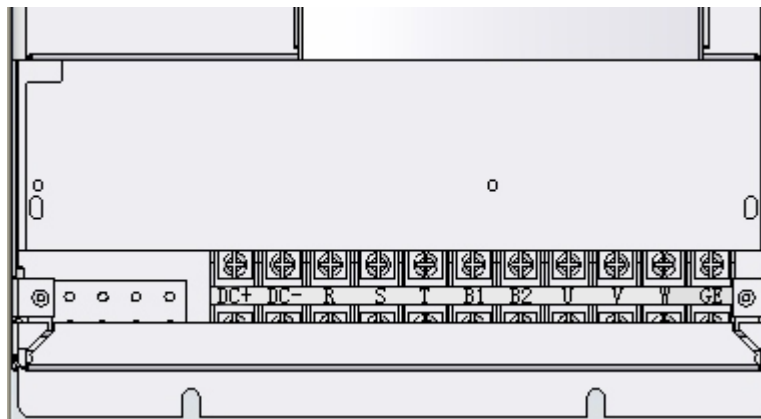

Figure 3.3 Terminal arrangement for main circuit

3.2.3. Main circuit terminal summary and function instruction

Table 3. 1 Main circuit terminal definition & function

| Terminal Symbol | Function Instruction |
|-----------------|--|
| R, S, T | Main circuit power input (380V/50Hz, 3 ϕ) |
| DC+ | DC BUS output + |
| DC- | DC BUS output - |
| B1、B2 | External Braking resistor terminal connection |
| U, V, W | Controller output terminal, connect with motor |
| DC+,DC- | Connect with battery device when system has ARD function |
| GE | Terminal connect to ground |

3.2.4. Wire specification for main circuit wiring

Table 3.2 Wire size and clamping torque for main circuit wiring

| Controller Model | Terminal Symbol | Screws | Clamping Torque N•m | Wire size (min) mm ² | Wire size (Rec) mm ² | Wire type |
|------------------|------------------------------------|--------|---------------------|---------------------------------|---------------------------------|--|
| BL3-B□4005 | DC+, DC-, R, S, T, B1, B2, U, V, W | M4 | 1.2~1.5 | 4 | 4 | Use power cable (e.g 600V vinyl power cable) |
| | GE | | | 2.5~4 | 2.5 | |
| BL3-B□4007 | DC+, DC-, R, S, T, B1, B2, U, V, W | M4 | 1.2~1.5 | 4 | 4 | |
| | GE | | | 4 | 4 | |
| BL3-B□4011 | DC+, DC-, R, S, T, B1, B2, U, V, W | M6 | 4~5 | 6~10 | 6 | |
| | GE | | | 6~10 | 6 | |
| BL3-B□4015 | DC+, DC-, R, S, T, B1, B2, U, V, W | M6 | 4~5 | 6~10 | 6 | |
| | GE | | | 6~10 | 6 | |
| BL3-B□4018 | DC+, DC-, R, S, T, B1, B2, U, V, W | M6 | 4~5 | 8~10 | 10 | |
| | GE | | | 8~10 | 10 | |
| BL3-B□4022 | DC+, DC-, R, S, T, B1, B2, U, V, W | M6 | 4~5 | 10~16 | 10 | |
| | GE | | | 10~16 | 16 | |
| BL3-B□4030 | DC+, DC-, R, S, T, B1, B2, U, V, W | M6 | 4~5 | 10~16 | 16 | |
| | GE | | | 10~16 | 16 | |
| BL3-B□4037 | DC+, DC-, R, S, T, B1, B2, U, V, W | M8 | 9~10 | 25~50 | 35 | |
| | GE | | | 25~50 | 35 | |
| BL3-B□4045 | DC+, DC-, R, S, T, B1, B2, U, V, W | M8 | 9~10 | 35~50 | 35 | |
| | GE | | | 35~50 | 35 | |

3.2.5. Main circuit wiring

3.2.5.1 WIRING MAIN CIRCUIT INPUT

Observe the following precautions when wiring the main circuit.

1. Installing a Molded-case Circuit Breaker (MCCB).

Connect the power input terminals(R、S、T)and power supply via a molded-case circuit breaker(MCCB) suitable for the controller. Choose an MCCB with a capacity of 1.8 to 2 times of the controller's rated current. For MCCB's timing characteristics, be sure to consider the controller's overload protection (60S at 150% of the rated output current, 10S at 180% of the rated output current).

2. Installing a Earthling Fault Interrupter

Controller outputs use high-speed switching, so high-frequency leakage current is generated. Therefore, at the controller input side, use an GND fault interrupter to detect only the leakage current in the frequency range that is hazardous to humans and exclude high-frequency leakage current. For a special-purpose GND fault interrupt, choose an GND fault interrupter with sensitivity amperage of at least 30mA per controller. When using a general GND fault interrupts, choose an GND fault interrupter with sensitivity amperage of 200mA or more per controller and with an operating time of 0.1s or more.

3. Installing a Magnetic Contactor.

Power input terminals(R、S、T) and power can be connected or be shut off through magnetic contactor (KMC) . Choose of magnetic contactor is according with the rated current of the controller. Make sure the contact capacity of magnetic contactor is greater than the rated current of the controller.

4. Wiring the terminals

If there is no phase sequence requirements, the input power supply can be connected with any one terminal (R、S、T, the phase sequence of input power supply is irrelevant to the phase sequence.

5. Installing a DC reactor

If necessary, take out the jumper in P1、(+) terminal of the controller, install the DC reactor. Never touch the P1、(+) terminal or the jumper with bare hand directly.

6. Installing Surge Absorber

Make sure using a surge absorber for inductive loads near the controller. These inductive loads include magnetic contactor, electromagnetic relays and magnetic brakes, and so on.

3.2.5.2 WIRING THE OUTPUT SIDE OF MAIN CIRCUIT

1. Connect the controller and Motor

Please connect the motor(input) wires to the output terminals U、V、W. Check that the motor rotates anticlockwise with the forward run command while running, otherwise, exchange the output terminal V and W.

2. Never connect a power supply to output terminals

Never connect a power supply to output terminals U、V、W. If voltage is applied to the output terminals, the internal circuit of the controller will be damaged.

3. Never short or GND output terminals

Never GND or short the output terminals. Never contact the controller with bare hands.

4. Never use capacity, surge absorber, power factor regulator and noise filter.

Never connect capacity, surge absorber, power factor regulator and noise filter to output circuit. The high-frequency components of the controller output may result in overheating or damage to these parts or may result in damage to the controller

5. Use of magnetic contactor

Don't connect a magnetic contactor between the controller and the motor and turn it ON or OFF during operation. Otherwise, a large inrush current will be created and the over current protection in the controller will operate. Before shut off the contactor, please stop the controller output first, after a while delay, then shut off.。

3.2.5.3 WIRING EARTH TERMINALS

1. Make sure to connect the earth protection terminal GE (GND resistance less than 10Ω).
2. Please do not share the GND with other devices such as welding machines or power tools.
3. Minimize the length and dimension of GND wire.
4. Please connect to earth at one point.

3.2.5.4 CONNECT BRAKE RESISTOR

1. There is an internal brake unit in the controller, but must equip an external resistor to absorb the feedback energy during brake. The configurations of the brake resistor are shown in **table 2.6**.
2. Connect brake resistor to terminal B1、 B2.
3. It is recommended to use heatproof wire with suitable specification and minimum length to connect brake resistor.
4. The installation of the brake resistor should consider the ventilated condition. Fan and protection cover are necessary to make sure ventilation and to avoid burn and electric shock.
5. Never contact the Terminals B1 and B2 with bare hands.

3.3. Wiring Control Circuit Terminals

3.3.1. Terminal Arrangement for Control Circuit

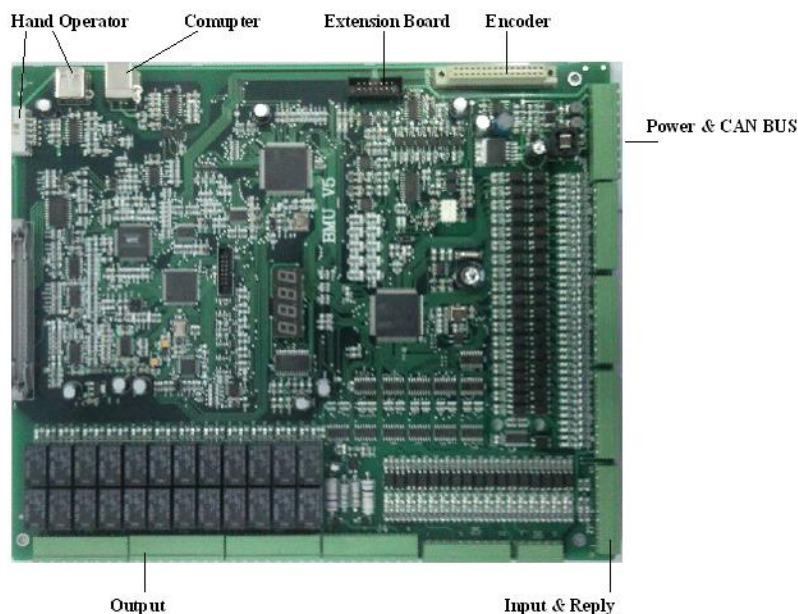

Figure 3.4 Terminal Arrangements for Control Circuit

Control circuit includes integrated control board, PG card and digital operator. PG card and digital operator will be introduced separately in **Chapter 4**. As elevator floor varies, the input, output of the controller and CAN communication interface is separate with the other parts of the controller, so the I/O interface of the controller should be connected with DC 24V power supply. Besides, DC 24V can also be used with HOP and COP. So the power supply should be equipped with suitable capacity according with the floor.

3.3.2. Terminal Connection for Control Circuit (Figure 3.1)

3.3.3. Control Circuit Port definition and Function

Table 3.3 Control Circuit Port definition and function list

| Port Name | Port Number | Location | Definition | Usage | Interface Tech Spec | | | |
|-----------|-------------|----------|--|--------|---------------------|-------------------------------|-------------|-----------|
| | | | | | Type | Rated Capacity | On/Off time | Max Speed |
| J1 | Y0 | J1_1 | KBC Brake | Output | Relay | DC 10A30V AC 10A250V | 5/10mS | 20cpm |
| | Y1 | J1_2 | KDY assist contactor | | | | | |
| | CM1 | J1_3 | Y0-Y1 Public | | | | | |
| | Y2 | J1_4 | KKM open door 1 | | | | | |
| | Y3 | J1_5 | KGM close door 1 | | | | | |
| | Y4 | J1_6 | KKM2 open door 2 | | | | | |
| | Y5 | J1_7 | KGM2 close door 2 | | | | | |
| | CM2 | J1_8 | Y2-Y5 Public | | | | | |
| J2 | Y6 | J2_1 | KXFL Fire-linkage | Output | Relay | DC 10A30V AC 10A250V | 5/10mS | 20cpm |
| | Y7 | J2_2 | Light off | | | | | |
| | Y8 | J2_3 | KDZZ Arrival Gong | | | | | |
| | CM3 | J2_4 | Y6-Y8 Public | | | | | |
| | Y9 | J2_5 | Ea lower 7-seg display a | | | | | |
| | Y10 | J2_6 | Eb lower 7-seg display b | | | | | |
| | Y11 | J2_7 | Ec lower 7-seg display c | | | | | |
| | Y12 | J2_8 | Ed lower 7-seg display d | | | | | |
| J3 | Y13 | J3_1 | Ee lower 7-seg display e | Output | Relay | DC 10A30V AC 10A250V | 5/10mS | 20cpm |
| | Y14 | J3_2 | Ef lower 7-seg display f | | | | | |
| | Y15 | J3_3 | Eg lower 7-seg display g | | | | | |
| | Y16 | J3_4 | EHbc higher 7-seg display bc (for 7-seg display, when higher bit is not used, it can be set as maintenance output using function code FU05) | | | | | |
| | Y17 | J3_5 | EHg higher 7-seg display g | | | | | |
| | Y18 | J3_6 | ES Up direction display | | | | | |
| | Y19 | J3_7 | EX Down direction display | | | | | |
| | CM4 | J3_8 | Y9-Y19 Public | | | | | |
| J4 | Y20 | J4_1 | Power off after parking (No output after parking) | Output | Relay | DC 10A30V AC 10A250V | 5/10mS | 20cpm |
| | Y21 | J4_2 | ECZ Overload output | | | | | |
| | Y22 | J4_3 | FMQ Buzzer | | | | | |
| | CM5 | J4_4 | Y20-Y22 Public | | | | | |
| | Y23 | J4_5 | Main contactor cut-off | | | | | |
| | CM6 | J4_6 | Y23 Public | | | | | |
| | X35+ | J4_7 | Door interlock + (110V—220VAC) | Input | Opto-Coupler | AC110V 8mA | 10mS | 100Hz |
| | X35- | J4_8 | Door Interlock(110V—220VAC) | | | | | |

Table 3.3 Control Circuit Port definition and function list (Cont'd)

| Port Name | Port Number | Location | Definition | Usage | Interface Tech Spec | | | |
|-----------|-------------|----------|---|-----------------|---|--|----------------|-----------------|
| | | | | | Type | Rated Capacity | On/Off time | Max Speed |
| J5 | I0 | J5_1 | SKYC Door open delay | Input Output | Input: Opto-Coupler Output: Open Collector | Input: DC24V 7mA Output: 300MA | Input: 10mS | Input: 100Hz |
| | I1 | J5_2 | Full/Single collective control Car call input 1/1 | | | | | |
| | I2 | J5_3 | Full/Single collective control Car call input 2/2 | | | | | |
| | I3 | J5_4 | Full/Single collective control Car call input 3/3 | | | | | |
| | I4 | J5_5 | Full/Single collective control Car call input 4/4 | | | | | |
| | I5 | J5_6 | Full/Single collective control Car call input 5/5 | | | | | |
| | I6 | J5_7 | Full/Single collective control Car call input 6/6 | | | | | |
| | I7 | J5_8 | Full/Single collective control Car call input 7/7 | | | | | |
| | I8 | J5_9 | Full/Down (Up) collective Landing Call Up input 1/ Car call input 8 | | | | | |
| | I9 | J5_10 | Full/Single collective control Landing Call Up input 2/ Car call input 9 | | | | | |
| J6 | I10 | J6_1 | Full/Single collective control Landing call Up input 3/ Landing call input 1 | Input Output | Input: Opto-Coupler Output: Open Collector | Input: DC24V 7mA Output: 300MA | Input: 10mS | Input: 100Hz |
| | I11 | J6_2 | Full/Single collective control Landing call Up input 4/ Landing call input 2 | | | | | |
| | I12 | J6_3 | Full/Single collective control Landing call Up input 5/ Landing call input 3 | | | | | |
| | I13 | J6_4 | Full/Single collective control Landing call Up input 6/ Landing call input 4 | | | | | |
| | I14 | J6_5 | Full/Single collective control Landing call Down input 2/ Landing call input 5 | | | | | |
| J7 | I15 | J7_1 | Full/Single collective control Landing call Down input 3/ Landing call input 6 | Input Output | Input: Opto-Coupler Output: Open Collector | Input: DC24V 7mA Output: 300MA | Input: 10mS | Input: 100Hz |
| | I16 | J7_2 | Full/Single collective control Landing call Down input 4/ Landing call input 7 | | | | | |
| | I17 | J7_3 | Full/Single collective control Landing call Down input 5/ Landing call input 8 | | | | | |
| | I18 | J7_4 | Full/Single collective control Landing call Down input 6/ Landing call input 9 | | | | | |
| | I19 | J7_5 | Full/Single collective control Landing call Down input 7/ Landing call input 10 | | | | | |

Table 3.3 Control Circuit Port definition and function list (Cont'd)

| Port Name | Port Number | Location | Definition | Usage | Interface Tech Spec | | | | | | | | |
|-----------|-------------|-------------------------|--------------------------------|-------|---------------------|----------------|-------------|-----------|------------|--------|-----------|--|--|
| | | | | | Type | Rated Capacity | On/Off time | Max Speed | | | | | |
| J7 | X0 | J7_6 | SIX Inspect/Auto | Input | Opto-Coupler | DC24V 7mA | 10mS | 100Hz | | | | | |
| | X1 | J7_7 | SSXW Up limit | | | | | | | | | | |
| | X2 | J7_8 | SXXW Down Limit | | | | | | | | | | |
| | X3 | J7_9 | SSMQ Up Leveling | | | | | | | | | | |
| | X4 | J7_10 | SXMQ Down Leveling | | | | | | | | | | |
| J8 | X5 | J8_1 | SKDY Assist Contactor Feedback | Input | Opto-Coupler | DC24V 7mA | 10mS | 100Hz | | | | | |
| | X6 | J8_2 | KBC Braking Contactor Feedback | | | | | | | | | | |
| | X7 | J8_3 | Door open limit 2 | | | | | | | | | | |
| | X8 | J8_4 | Door close limit 2 | | | | | | | | | | |
| | X9 | J8_5 | Door safety plate 2 | | | | | | | | | | |
| | X10 | J8_6 | SJT Emergency stop | | | | | | | | | | |
| | X11 | J8_7 | SMB Door inter-lock | | | | | | | | | | |
| | X12 | J8_8 | Undefined | | | | | | | | | | |
| | X13 | J8_9 | SXF Fire linkage | | | | | | | | | | |
| J9 | X14 | J8_10 | SMS Slow up (Attendant up) | Input | Opto-Coupler | DC24V 7mA | 10mS | 100Hz | | | | | |
| | X15 | J9_1 | SMX Slow down (Attendant down) | | | | | | | | | | |
| | X16 | J9_2 | SSDZ Up terminal | | | | | | | | | | |
| | X17 | J9_3 | SXDZ Down terminal | | | | | | | | | | |
| | X18 | J9_4 | Undefined | | | | | | | | | | |
| | X19 | J9_5 | SKM Door open signal 1 | | | | | | | | | | |
| | X20 | J9_6 | SGM Door close signal 1 | | | | | | | | | | |
| | X21 | J9_7 | SKMW1 Door open limit 1 | | | | | | | | | | |
| | X22 | J9_8 | SGMW1 Door close limit 1 | | | | | | | | | | |
| J10 | X23 | J9_9 | STAB1 Door safety plate 1 | Input | Opto-Coupler | DC24V 7mA | 10mS | 100Hz | | | | | |
| | X24 | J9_10 | SDS Electronic Lock | | | | | | | | | | |
| | X25 | J10_1 | SCZ Overload signal | | | | | | | | | | |
| | X26 | J10_2 | SMZ Full load signal | | | | | | | | | | |
| | X27 | J10_3 | Undefined | | | | | | | | | | |
| | X28 | J10_4 | Under load anti-mischief | | | | | | | | | | |
| | X29 | J10_5 | SZH Attendant signal | | | | | | | | | | |
| | X30 | J10_6 | SZS Drive signal | | | | | | | | | | |
| | X31 | J10_7 | Brake switch | | | | | | | | | | |
| | X32 | J10_8 | Heat sensor switch | | | | | | | | | | |
| J11 | X33 | J10_9 | SKM2 Door open signal 2 | Power | Power | DC 24V 10A | | | | | | | |
| | X34 | J10_10 | SGM2 Door close signal 2 | | | | | | | | | | |
| | +24V1 | J11-1 | Input Public | | | | | | | | | | |
| | 24V_GND | J11-2, J11-3 | Power input GND | | | | | | | | | | |
| | +24V | J11-4 | Power input | | | | | | | | | | |
| | AG0 IN | J11-5 | Analog input | | | | | | Input | Analog | -10V~+10V | | |
| | GND1 | J11-6 | GND | | | | | | Ana In GND | | | | |
| 1H | J11-7 | Parallel/Group Control+ | Communi- cation | CAN | 80mA | | 25KH | | | | | | |
| 1L | J11-8 | Parallel/Group Control- | | | | | | | | | | | |

3.3.4. Wire size for Control Circuit Terminals

600V plastic insulated wire should be used. Choose suitable wire size based on Table 3.4

Table 3.4 Wire size for Control circuit terminals

| Terminal Function | Acceptable Wire size (mm ²) | Recommended wire size (mm ²) | Clamping Torque N.m | Special Requirement |
|-------------------|---|--|---------------------|---------------------|
| Input/ Output | 0.5~1 | 0.75 | 0.5~0.6 | |
| PG Car I/O | 0.15~0.5 | 0.3 | 0.5~0.6 | Twisted pair shield |
| CAN COMM | 0.75~1.5 | 0.75 (≤10 floors) 、 1.5 (>10 floors) | 0.5~0.6 | Twisted pair shield |

3.3.5. Control Circuit I/O interface and wiring

3.3.5.1 DIGITAL VALUE INPUT INTERFACE

The common terminal of board for digital value input interface is +24V, so it should be contactor input or common emitter input (0V common terminal) as shown in Fig 3.5 and Fig 3.6.

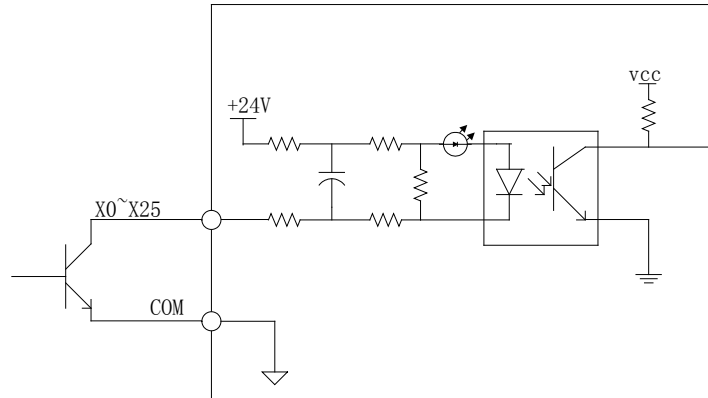

Figure 3.5 Common Emitter Input

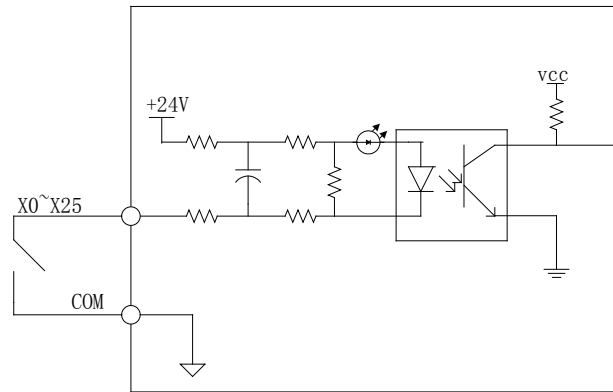

Figure 3.6 Contactor Switch Input

3.3.5.2 CAN COMM INTERFACE

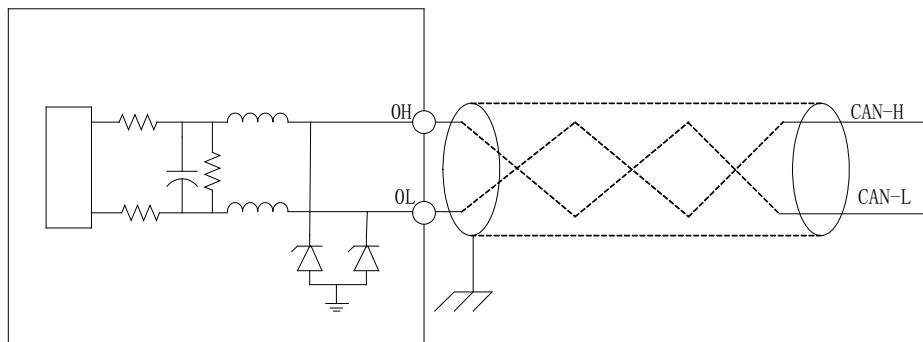

Figure 3.7 CAN COMM Interface and Connection

The controller, COP and HOP are connected through CAN bus. The reliability of CAN BUS communication is directly related to cable wiring. It is specifically required that shaft cable and traveling cable should be **twisted-pair shield cable**. The twisted-pair can stop the differential mode interference of the long wire while shield can isolate the electromagnetic interference caused during elevator running. The function and connection of the CAN communication interface is shown in the Fig 3.7.

3.3.5.3 ANALOG INPUT INTERFACE

The voltage range of analog input interface is -10~+10V, for selecting the load information provided by weighing device. As analog signal is easy to get interference, the wire of analog input terminal should be TWISTED-PAIR SHIELD CABLE. Its input and connection is shown in Fig 3.8.

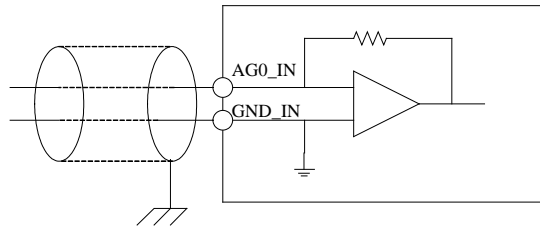

Figure 3.8 Analog Input & Connection

3.3.5.4 AC 100V INPUT INTERFACE

AC 110V input interface is for testing of Emergency stop/Door Drive. Its interface/connection is shown in Fig 3.9

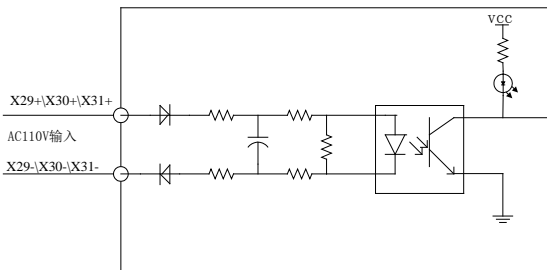

Figure 3.9 AC110V Input Interface & Connections

3.3.5.5 POWER SUPPLY INPUT INTERFACE

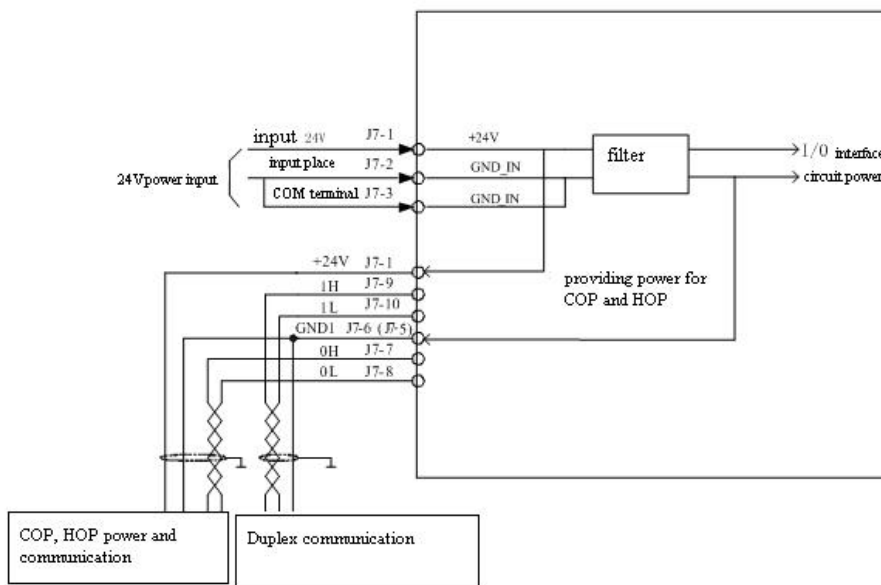

Figure 3.10 Power Supply Interface & Connections

3.4. PG Card Installation & Wiring

3.4.1. PG_V31 Interface Card

PG-V31 interface card can be used for both synchronous/asynchronous motors, with the function of pulse encoder speed feedback and frequency output.

The card is compatible for 12V OC output, push-pull output and 5V long wire drive pulse encode output, It can used with both synchronous machine encoder(A/B) and asynchronous machine encoder (A/B/Z/U/V/W). Please see Fig 3.11 below for detail.

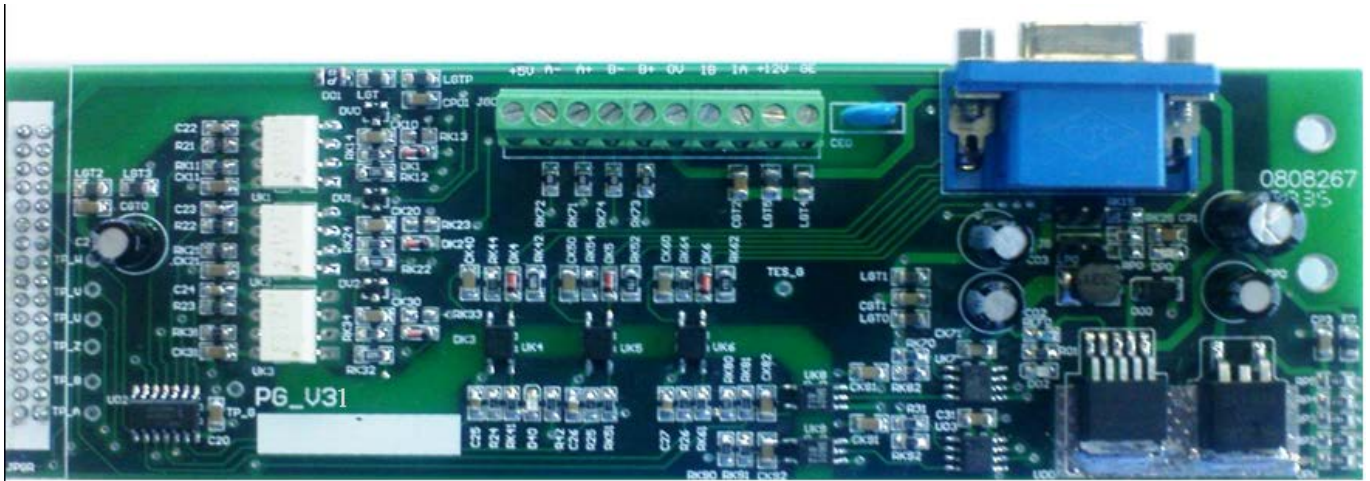

Figure 3.11 PG_V31 Card

3.4.2. Installation and Remove PG_V31

When installing PG-V31 card, first cut off the controller power supply, make sure that charge indicator LED on the controller is off. Then remove the controller and the front cover and install the PG-V31 card.

Installation procedures: first match the connector of the PG-V31 card (welding parts) towards the JPGR connector of the main control board. Match the other two installation hole toward the corresponded two nylon tube (pre-installed). Then keep the PG-V31 card horizontal and press the card stable until the connector and the nylon tube are installed closely with no gap in between.

Removing procedures: first cut off the controller power supply, make sure that the charge indicator LED on the controller is off. Then remove the controller and front cover, remove the terminal connection of PG-V31 card. Isolate the removed wire carefully, don't contact with other charged objects. Then remove the D-type connector, hold the embossed part of the nylon tube with needle point pliers, raise the PG card slowly until the embossed part is taken out. Follow the same procedures with the other nylon tube. Finally remove the PG card.

Precautions for installing and removing

1. Don't touch the chip with bare hand directly, to avoid the static charge damage the chip.
2. Choose suitable tool, such as screwdriver, needle point pliers and else.
3. Never damage the components of the card.
4. Never damage the components of the main control board.
5. While recovering the connection, please connect as per wire number and the requirements; make sure the connections are correct.
6. Please make sure the jumpers on the new card and the old card are same.

3.4.3. PG_V31 Terminal Definition & Function List

Table 3.5 PG—V31 Card Terminal Definition & Function

| Terminal Name | Terminal Mark | Location | Definition | Usage | Interface Technical Specification | | | |
|---------------|---------------|----------|---|------------------------------------|-----------------------------------|----------------|-------------|-----------|
| | | | | | Interface Type | Rated Capacity | On/Off Time | Max Speed |
| JG0 | +5V | JG0-1 | Power supply | 5V Power supply | Power output | +200mA/5V±5% | | |
| | A- | JG0-2 | Frequency signal differential output A- | synchronization frequency division | Differential output | ±50mA | | 500KHz |
| | A+ | JG0-3 | Frequency signal differential output A+ | synchronization frequency division | Differential output | ±50mA | | 500KHz |
| | B- | JG0-4 | Frequency signal differential output B- | synchronization frequency division | Differential output | ±50mA | | 500KHz |
| | B+ | JG0-5 | Frequency signal differential output B+ | synchronization frequency division | Differential output | ±50mA | | 500KHz |
| | OV | JG0-6 | Power supply Ground | Power supply Ground | Power supply GND | — | | |
| | IB | JG0-7 | OC/ push-pull type B phase input | Input signal B | OC/ push-pull input | -10mA/12V-15V | | 500KHz |
| | IA | JG0-8 | OC/ push-pull type A phase input | Input signal A | OC/ push-pull input | -10mA/12V-15V | | 500KHz |
| | +12V | JG0-9 | OC/push-pull type power supply | 12V power supply | Power output | +150mA/12V±5% | | |
| | GE | JG0-10 | Shield Ground | Shield Ground | | — | | |
| JG1 | +5V | JG1-1 | +5V | 5V power supply | Power output | +400mA/5V±5% | | |
| | U+ | JG1-2 | U+ | Differential signal U+ | Differential input | ±20mA/3.1-5V | | 500KHz |
| | Z+ | JG1-3 | Z+ | Differential signal Z+ | Differential input | ±20mA/3.1-5V | | 500KHz |
| | B+ | JG1-4 | B+ | Differential signal B+ | Differential input | ±20mA/3.1-5V | | 500KHz |
| | A+ | JG1-5 | A+ | Differential signal A+ | Differential input | ±20mA/3.1-5V | | 500KHz |
| | GND | JG1-6 | GND | 5V GND | Power supply GND | — | | |
| | U- | JG1-7 | U- | Differential signal U- | Differential input | ±20mA/3.1-5V | | 500KHz |
| | Z- | JG1-8 | Z- | Differential signal Z- | Differential input | ±20mA/3.1-5V | | 500KHz |
| | B- | JG1-9 | B- | Differential signal B- | Differential input | ±20mA/3.1-5V | | 500KHz |
| | A- | JG1-10 | A- | Differential signal A- | Differential input | ±20mA/3.1-5V | | 500KHz |
| | GND | JG1-11 | GND | 5V Ground | Power supply GND | — | | |
| | V+ | JG1-12 | V+ | Differential signal V+ | Differential input | ±20mA/3.1-5V | | 500KHz |
| | V- | JG1-13 | V- | Differential signal V- | Differential input | ±20mA/3.1-5V | | 500KHz |
| | W+ | JG1-14 | W+ | Differential signal W+ | Differential input | ±20mA/3.1-5V | | 500KHz |
| | W- | JG1-15 | W- | Differential signal W- | Differential input | ±20mA/3.1-5V | | 500KHz |



IMPORTANT

The parameter above given is for PG-V3w interface card work in the environment temperature of 0°C-70°C, if the temperature is higher than 70°C, PG interface card may not work normally or even damage.

3.4.4. PG_V31 Connection for 12V push-pull/OC output encoder (for Asynchronous Machine)

Connection of PG-V31 card and 12V push-pull/OC output encoder (for asynchronous machine) is shown in Fig 3.12



Jumper JA and JB should be shorted, connect the 12V/B/A/0V on the encoder to the PG card terminal +12V/IB/IA/0V (the terminal 7/8/9/10 of JG0) one-by-one.

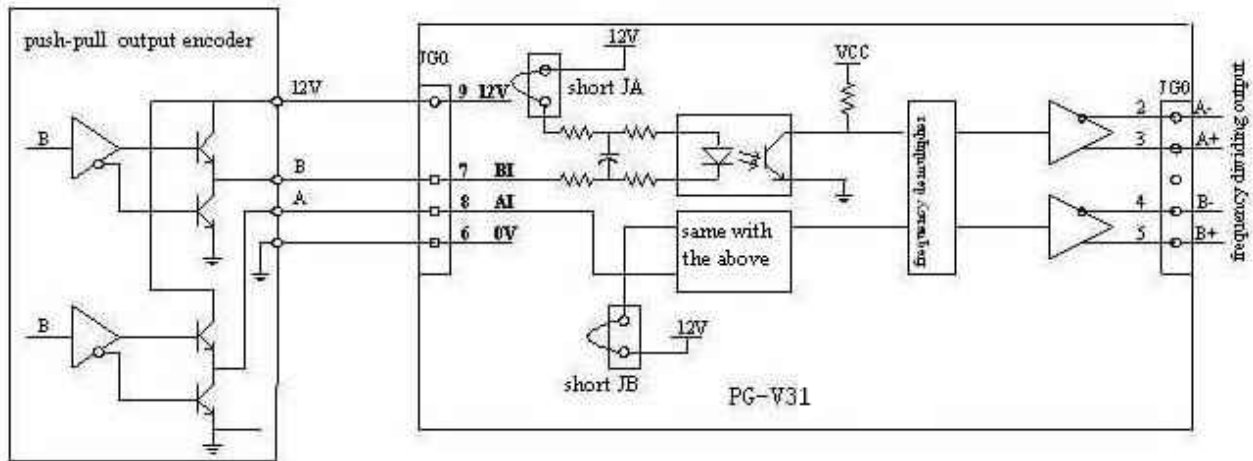

Figure 3.12 PG_V31 card connections with 12V push-pull/OC output encoder

3.4.5. PG_V31 card connection with 5V long cable drive output encoder (for Asynchronous Machine)

The connection of PG-V31 card and 5V long cable drive output encoder (for asynchronous machine) is shown in Fig 3.13.



Jumper JA and JB should be shorted (Factory setting for JA and JB jumper is off), then connect the 5V/B+/A+/B-/A-/0V of encoder to the +5V/B+/A+/B-/A-/GND of the D-type connection on terminal JG1 (the related pin of 1/4/5/9/10/6 of JG1 for D-type connection part). Make sure the wiring connection is correct, then connect plug and lock well.



图 3.13 PG_V31 connection with 5V long cable drive output encoder (for asynchronous machine)

3.4.6. PG_V31 card connection with 5V long cable drive output encoder (for Synchronous Machine)

The connection of PG-V31 card and 5V long cable drive output encoder (for synchronous machine) is shown in Fig 3.14

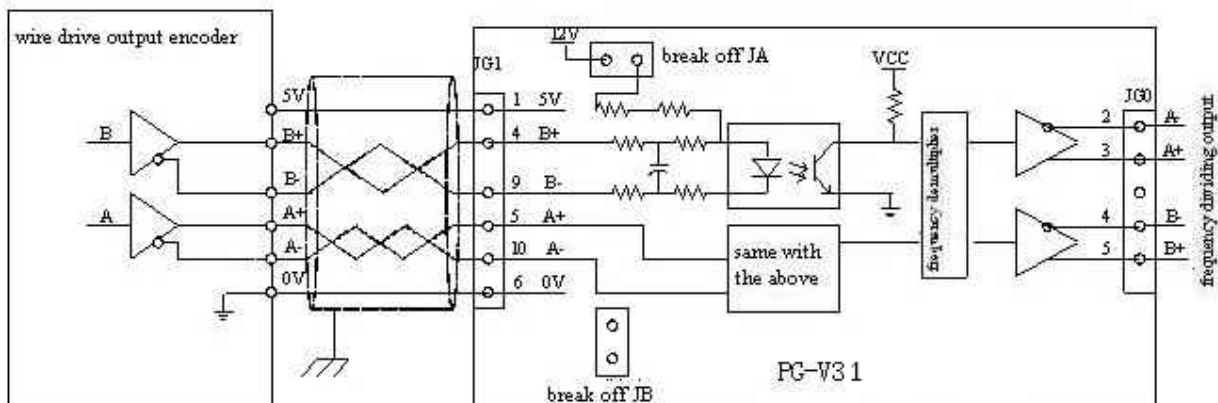

Jumper JA and JB should be disconnected (Factory setting for JA and JB wire jumper is off), then connect the 5V/0V/A+/A-/B+/B-/Z+/Z-/U+/U-/V+/V-/W+/W- of encoder to the +5V/GND/A+/A-/B+/B-/Z+/Z-/U+/U-/V+/V-/W+/W- of the D-type connection on terminal JG1 (the related pin of 1/6/5/10/4/9/3/8/2/7/12/13/14/15 of JG1 for D-type connection part). Make sure the wiring connection is correct, then connect plug and lock well.

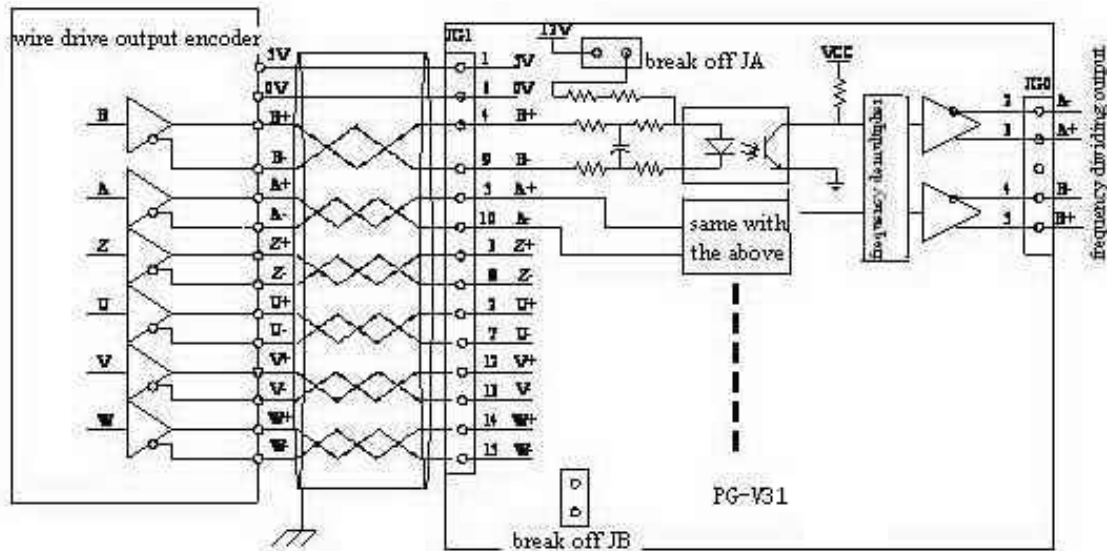

Figure 3.14 PG_V31 connection with 5V long cable drive output encoder (for synchronous machine)

3.4.7. Precautions for using PG_V31 card

For the 15 pin differential output encoder interface of the PG-V31 card and the OC/push-pull output encoder interface, the input pulse signal frequency is required to be no more than 500 KHz, the parameter of the input and output signal current and voltage cannot exceed the range given in the table 3.5 above.

If the parameter of the input and output signal current and voltage exceed the given range, the PG interface card and encoder may not work abnormally or even get damaged

Manufacturer suggests that once the external circuit condition is not well, to avoid PG card interference or getting damaged, please do not power up other circuits with the PG-V31 interface card +5V power supply except the encoder.

Never connect the PG-V31 interface card to OC/push-pull output encoder interface and the differential output encoder interface at the same time. Otherwise, the encoder and the PG—V31 card may be damaged.

When using the differential output encoder interface, it is necessary to make one D type plug with 3 line 15 pin corresponding with the “JG1” connector of the PG-V31 interface card. Also, **DO NOT** connect jumper “JA” and “JB”. When using OC/push-pull output encoder interface, the signal interface in the “JG0” terminal can be connected directly, and the jumper “JA” and “JB” **MUST BE** connected. The position of “JA” and “JB” doesn’t affect the use of the frequency signal differential output function.

Please note that user shall take responsibility for the consequence caused by the reasons above.

3.4.8. SPG_V33 Interface Card

SPG-V33 interface card is shown in the Fig 3.15



Figure 3.15 SPG_V33 Card

3.4.9. SPG_V33 Interface Card Terminal Definition and Function List

Table 3.6 SPG_V33 Terminal Definition & Function (D-input/output refers to Differential input/output)

| Terminal Name | Terminal Mark | Location | Definition | Usage | Interface Technical Specification | | | |
|---|---------------|-----------|--------------------------|-------------------------|-----------------------------------|--|-------------|-----------|
| | | | | | Interface Type | Rated Capacity | On/Off Time | Max Speed |
| JENDAT (For frequency dividing signal) | +5V | JENDAT -1 | Power Supply | 5V power supply | Power output | +500mA/5V±2.5% Voltage ripple <50mV | | |
| | B- | JENDAT -2 | D-output B- | Sync-frequency division | D-output | 5V/±50mA | | 250KHZ |
| | B+ | JENDAT -3 | D-output B+ | Sync-frequency division | D-output | 5V/±50mA | | 250KHZ |
| | A- | JENDAT -4 | D-output A- | Sync-frequency division | D-output | 5V/±50mA | | 250KHZ |
| | A+ | JENDAT -5 | D-output A+ | Sync-frequency division | D-output | 5V/±50mA | | 250KHZ |
| | GND | JENDAT -6 | Power Ground | Power Ground | PGND | | | |
| | GND_E | JENDAT -7 | Encoder shield cable GND | | | | | |
| | GND_E | JENDAT -8 | Encoder shield cable GND | | | | | |
| JG1 | B- | JG1-1 | B- | Differential signal B- | Differential input | | | 40KHz |
| | * | JG1-2 | — | — | — | | | |
| | R+ | JG1-3 | R+ | Differential signal R+ | D-input | | | 40KHz |
| | R- | JG1-4 | R- | Differential signal R- | D-input | | | 40KHz |
| | A+ | JG1-5 | A+ | Differential signal A+ | D-input | | | 40KHz |
| | A- | JG1-6 | A- | Differential signal A- | D-input | | | 40KHz |
| | 0V | JG1-7 | GND | 5V Ground | PGND | | | |
| | B+ | JG1-8 | B+ | Differential signal B+ | D-input | | | 40KHz |
| | 5V | JG1-9 | +5V | 5V power | Power output | +500mA/5V±2.5% Voltage ripple <50mV | | |
| | C- | JG1-10 | C- | Differential signal C- | D-input | | | 40KHz |
| | C+ | JG1-11 | C+ | Differential signal C+ | D-input | | | 40KHz |
| | D+ | JG1-12 | D+ | Differential signal D+ | D-input | | | 40KHz |
| | D- | JG1-13 | D- | Differential signal D- | D-input | | | 40KHz |
| | * | JG1-14 | — | — | — | | | |
| | * | JG1-15 | — | — | — | | | |

3.4.10. SPG_V33 Interface Card Circuit

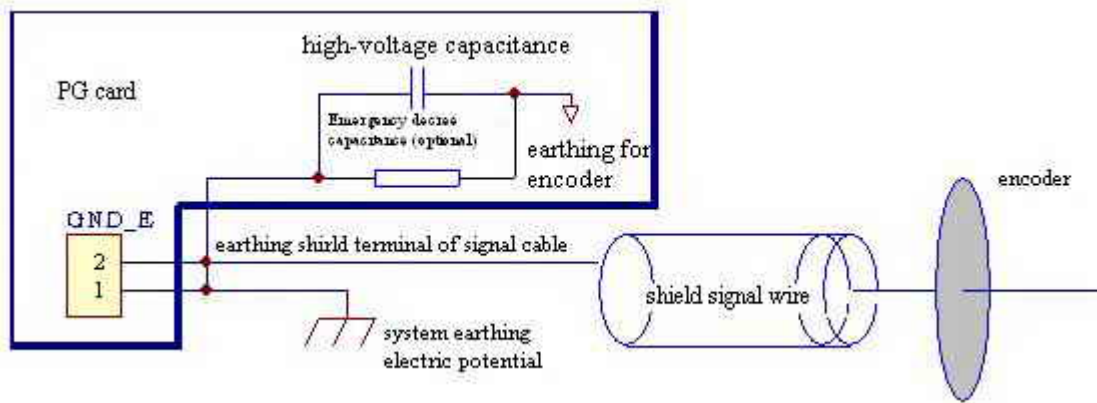

Figure 3.16 SPG_V33 Card



The resistor for ground terminal GND_E is not essential component. There might be different requirement between different versions.

3.4.11. Precautions for using SPG_V33

1. Sine/cosine PG card can provide power output of $5V \pm 2.5\%$ /500mA for encoder. If the current required exceeds the PG card rated value, it may damage the PG card or encoder.
2. The cut-off frequency of the analog input signal is requested to be lower than 40KHz. This is decided by filter circuit. If the input signal bandwidth exceeds this range, PG card cannot guarantee to analyze the signal correctly and the driver may not work properly.
3. If use the frequency output function that PG card provided, make sure that the current in frequency dividing interface is within rated level to avoid any unwanted circuit protection mechanism. Also, the maximum frequency dividing output rate is 250KB/S; beyond such limit of the speed rate may cause frequency dividing signal not output properly.
4. PG card can set two different gains for A, B, C, D signal. A and B signal is set through jumper "SGA" and "SGB". Generally, "SGA" and "SGB" are not shorted and the gain is set as smaller value. If the signal cable of the encoder at site is longer than 7 meters, it is suggested to short the "SGA" and "SGB" to set the gain as larger value, which can compensate the signal attenuation caused by the increased line impedance. In order to get signal with larger gain value to minimize the effect of different conductor characteristics, please short "SGA" and "SGB" directly. Also, it is suggested to compare the signal quality without load compensation, if the effect of shorting and un-shortening "SGA" and "SGB" is same, it is better to short "SGA" and "SGB". Also, please note to short or open "SGA" and "SGB" at the same time, otherwise PG card will not work properly; C and D signal is set through the status of jumper "SGC" "SGD", procedures are the same with A,B.
5. The two ground terminal of GND_E is connected inside. At site, one terminal is required to connect to the system GND wires, and the GND resistance should be minimized with independent ground connection point. The other terminal is connected to the shielding layer of the signal cable for the sine/cosine encoder. For the shielding layer of the signal cable, it is suggested that two terminals are grounded at both sides or at the end terminal of GND_E side. As the output signal of the sine/cosine encoder is small analog signal which is easier to get interference, it is better to use the recommended signal cable with complete shield layer, lower transfer impedance and wire twin twisted. Inappropriate ground connection or use unsuitable signal transfer cable may result in system not working properly.

6. Older version SPG_V33 has the function of locate encoder position through C, D signal (The UPC of PG card on the back is 20106_**_01050000_*****_**_***_*****). If want to use this function, please make sure the jumper S_CD is shorted before power on; New version SPG_V33 has the function of locate encoder position through C, D signal (The UPC of PG card on the back is 20106_**_01060000_*****_**_***_*****), the function of encoder cable break testing and starting with no-load compensation. If want to use this function, please make sure the jumper S_CD is disconnected before power on.
7. Jumper S_XF is kept for future adjustments, please keep it disconnected.

3.5. Precautions with Wiring

1. Before connection, please pay attention to the precautions mentioned in chapter 1.2, especially the “warning” and “caution” part.
2. Before connection, make sure that the power supply is off.
3. Please ask professional engineers with training and authorization for the wiring.
4. The wire size and clamping torque should follow the regulation of Table 3.2 and Table 3.4
5. To increase wiring convenience and reliability, it is better to use round crimp type terminal (for main circuit) and club-shaped terminal (for control circuit).
6. Wire the control circuit/main circuit/power supply separately.
7. CAN communication cable、encoder cable、encoder frequency output cable and analog input cable should use TWISTED-PAIR SHIELD CABLE.
8. Please ground the cable shield wire correctly, and maximize the contact area.
9. Make sure the length of signal cable for PG/encoder is within 30m, minimize the length.
10. Make sure the cable between controller and machine is within 100m, minimize the length.
11. Make sure the brake resistor is connected between B1 and B2.
12. Make sure the connection of ground terminal GE is secure, do not share the ground cable with other devices such as welding machines or power tools. Minimize length and dimension of ground cable and ground at one point.
13. After wiring, make sure check the following:
 - a. Correctness and reliability of connection.
 - b. Whether there is leftover, such as wire, screw and metal filing
 - c. Whether the connection of the screw, the terminals and the connection parts is loose.
 - d. Whether the bare conductor of terminals is connected with other terminals.

Chapter 4: Operator

BL3—U series elevator integrated controller is equipped with LCD digital operator OP-V6. It is a special tool for commissioning and maintenance of control system. It provides a nice and easy human-machine interface with both Chinese and English on display.

4.1. Key, display and function of Operator

The digital operator OP-V6 has the main LCD screen with resolution of 128×64 LCD, 5 LED and 11 function buttons.

Please see figure 4.1 below for detail.

4.1.1. Operator LED Display

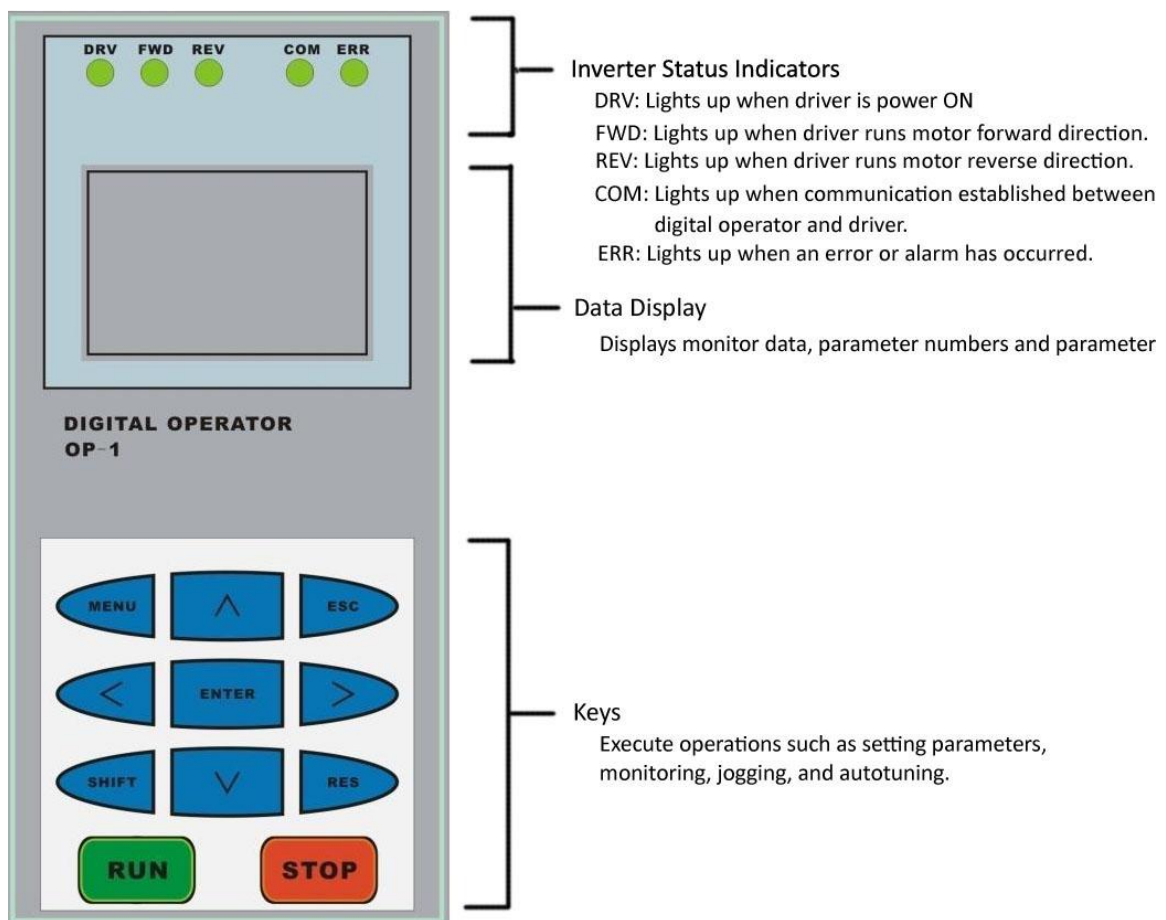













Figure 4.1 Digital Operator Display and button

4.1.2. Operator Keys

Table 4.2 Operator Keys names and functions

| Keys | Name | Function Description |
|---|-------------|---|
|  | [RUN] Key | Run the controller in keypad control mode; button is disabled in program control mode. Enable/disable is set through parameters. |
|  | [STOP] Key | Stop the controller in keypad control mode; button is disabled in program control mode. Enable/disable is set through parameters. |
|  | [MENU] Key | Return to main menu on any screen. |
|  | [SHIFT] key | Enable the 2 nd function of other keys. |
|  | [RESET] Key | Enter the digit setting option for certain parameters. |
|  | [UP] Key | Scroll up menu options or edit figures in certain setting page. 2 nd function: Scroll up 10 options. |
|  | [DOWN] Key | Scroll down menu options or edit figures in certain setting page. 2 nd function: Scroll down 10 options. |
|  | [LEFT] Key | For parameter setting, choose the left digit for editing. |
|  | [RIGHT] Key | For parameter setting, choose the right digit for editing. |
|  | [ENTER] Key | Enter the next level sub-menu on main screen; Input set value on parameter setting; Give command; Check fault/warning information. |
|  | [ESC] Key | Return the previous level menu. |

4.1.3. LCD Display

Controller enters the main interface after power on. The main interface is shown in Fig 4.2

The main interface displays the main information of the elevator in present status, including floor number, elevator speed, running direction, door lock status, running model, fault code and else. On the main interface, the above information is live updated.

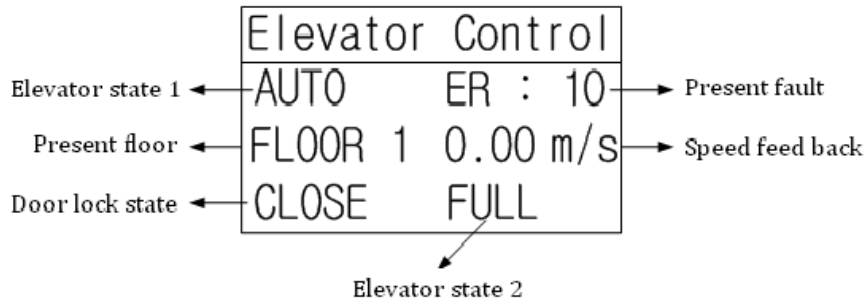

Figure 4.2 Main interface on digital operator

The instructions for the information shown in the Digital operator LCD display interface are as following:

1. The status of the elevator display1:

| | | |
|------|------|------|
| INSP | MANU | AUTO |
| FIRE | STOP | USER |

2. Present floor display:

Display the floor number that the elevator is at.

3. Door lock status:

CLOSE/OPEN: Door inter-lock circuit closed/opened.

4. The status of the elevator display 2:

| | |
|--------|----------------|
| FULL: | full load |
| OVER: | overload |
| GROUP: | group control |
| TWINS: | Duplex control |

5. Present error:

ERR: XX display the present Error code.

4.1.4. Function of Operator

The function of digital operator is as follows:

1. LCD display with English and Chinese
2. Setting log in level and corresponded password.
3. Adjusting the settings of quick menu
4. Monitor the status of the elevator and the controller.
5. Parameter check, setting and save.
6. Hoistway learning
7. Motor parameter learning
8. Weighing data learning
9. System clock setting
10. Error history log record and check.
11. Parameter copy, upload and download.
12. Restore to factory setting.

4.1.5. Installation and Connection of Operation

The installation and dismantle of the enclosed digital operator please follow **page 2 to 9 in the chapter 2.7.5**

The connection for the digital operator of the opening controller is as follows: remove the front cover of the controller, connect one side of the special communication cable to digital operator, and connect the other side to the J232_T connection on the main board. Make sure the connection is tight; install the front cover of the controller.

1. The installation, dismantle, insert and remove of the digital operator can be carried out when the controller is power-on. That is to say, hot plug is accepted by the digital controller.



2. Please install, dismantle, insert and remove the digital operator carefully to avoid unwanted damage of the digital operator.

3. Please save the removed digital operator and communication cable well, DO NOT press, damage the operator or put it in extreme environment.

4. Please DO NOT use the self-made (> 3m) communication cable.

4.2. Structure flowchart of Operator menu

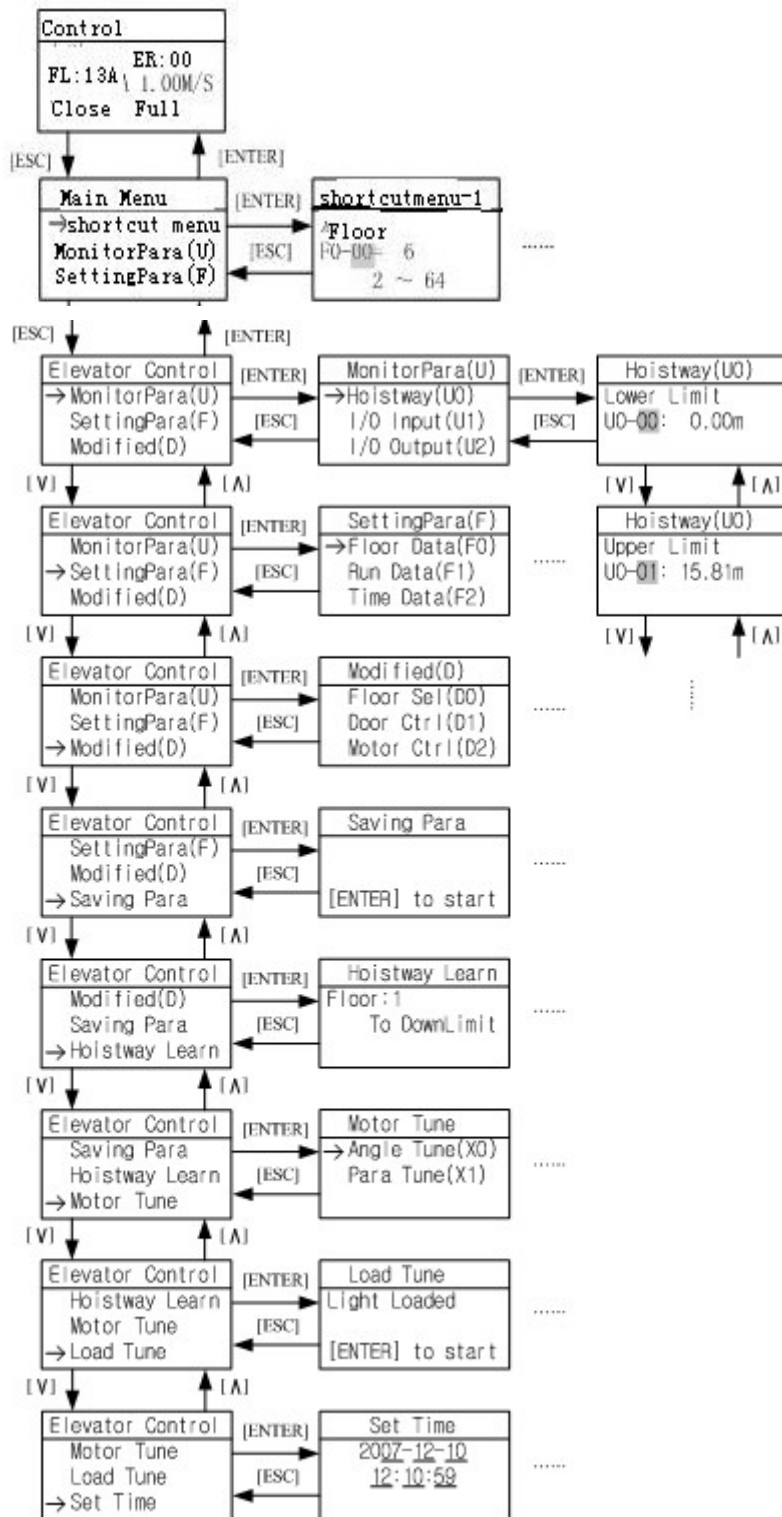

Figure 4.3 Structure flowchart of Operator menu

4.3. Parameter Setting

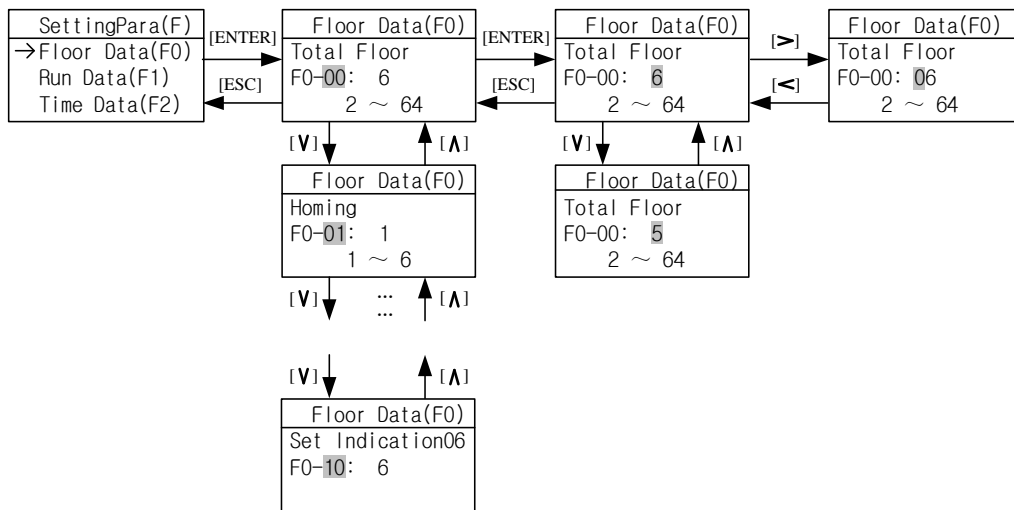

Figure 4.4 Parameter setting

In the interface of parameter menu: Press [ENTER] key to enter the interface. (First, it should input the correct user password in the environment setting menu, otherwise, pressing the [ENTER] key will enter the interface of user password setting. So please pay attention to distinguish the factory password and user password. If you want to input the factory password, please press the [ESC] key, returning to previous menu, then press the [DOWN] key to change the prompt to “input the factory password”, after that press the [ENTER] key, entering to the interface of the inputting factory password). Press the [UP] or [DOWN] key to check all the parameters. Please press the [ENTER] key to enter the interface of parameter menu. Please press [LEFT] or [RIGHT] key to move the arrow to left or right. Press the [UP] or [DOWN] to increase or decrease the value that the arrow point at. After setting the value, please press the [ENTER] key to save the parameter.

Some parameter values are combination values of the status. Their setting cannot follow the above flowchart directly and should follow the Tooltip in the parameter changing interface. Press [RES] key to enter the bit parameter setting interface to set the status value as per the bit. After enter the bit parameter setting interface, press [UP] or [DOWN] key to check the status of the present bit. When the status of the present bit need to be changed, press [ENTER] key to enter the status change interface. In the status change interface, press [UP] or [DOWN] key to check the status of the present bit, press the [ENTER] key to save the status of the present bit, press [ESC] key to return the Previous Menu

The flowchart of setting of bit parameters is shown in Fig 4.5

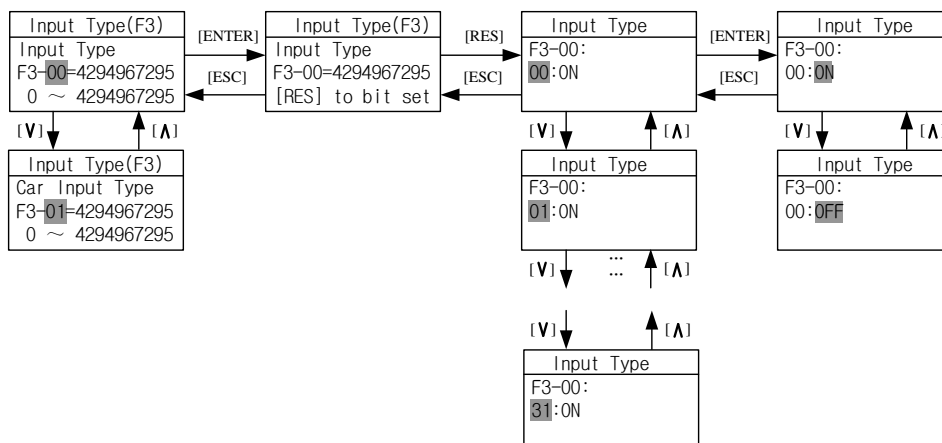

Figure 4.5 Setting bit Parameters

4.4. Commissioning Parameters

In commissioning interface: Move the arrow by pressing [UP] key or [DOWN] key to carry out the operation, press [ENTER] to enter the selected interface.

In floor selection interface: Press [UP] key or [DOWN] key to check the car call status in present floor. If need to set car call on current floor, press [ENTER] key in the interface to save the car call information. In the interface, the information follow “F:” is the present floor the elevator car at.

Floor selection flowchart is shown in Fig 4.6

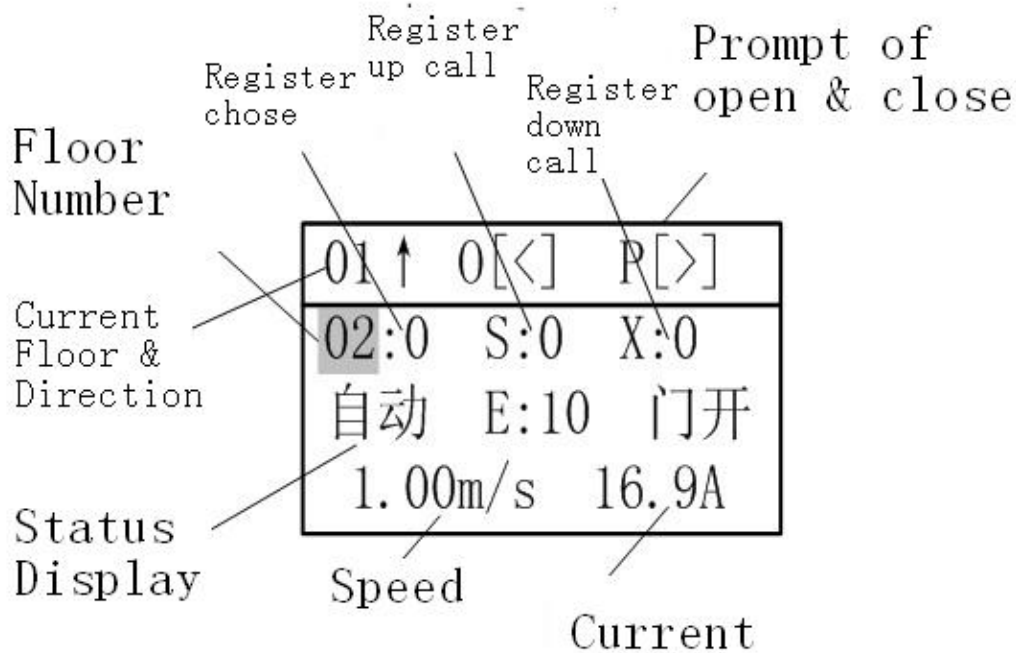

Figure 4.6 Floor selection

In the interface of door control: Press [LEFT] key in the interface to carry out the command “opening front door”. Press [RIGHT] key to carry out the command “close front door”. Press [UP] key to carry out the command “open rear door”. Press [DOWN] key to carry out the command “close rear door”, Press [RES] key to cancel all the commands.

Door open and close flowchart is shown in Fig 4.7

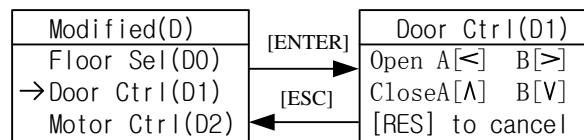

Figure 4.7 Door Control interface

In Motor Control interface: Press [UP]/ [DOWN] key to select the running mode is continuous running or JOG. In the mode of continuous running, first press [RUN] key to start motor, press [UP]/ [DOWN] key to increase/decrease the motor given speed. The motor given speed can be negative (negative speed means motor reverse run), press [ENTER] key to save the given speed. Press [STOP] key to stop the motor. In the mode of JOG, press [UP]/ [DOWN] key to increase/decrease the JOG operation frequency, after press the [ENTER] to save the setting, and then press the [RUN] key to start, and press the [STOP] to stop the operation.

The flowchart for operator to control the motor running is shown below in the Fig 4.8.

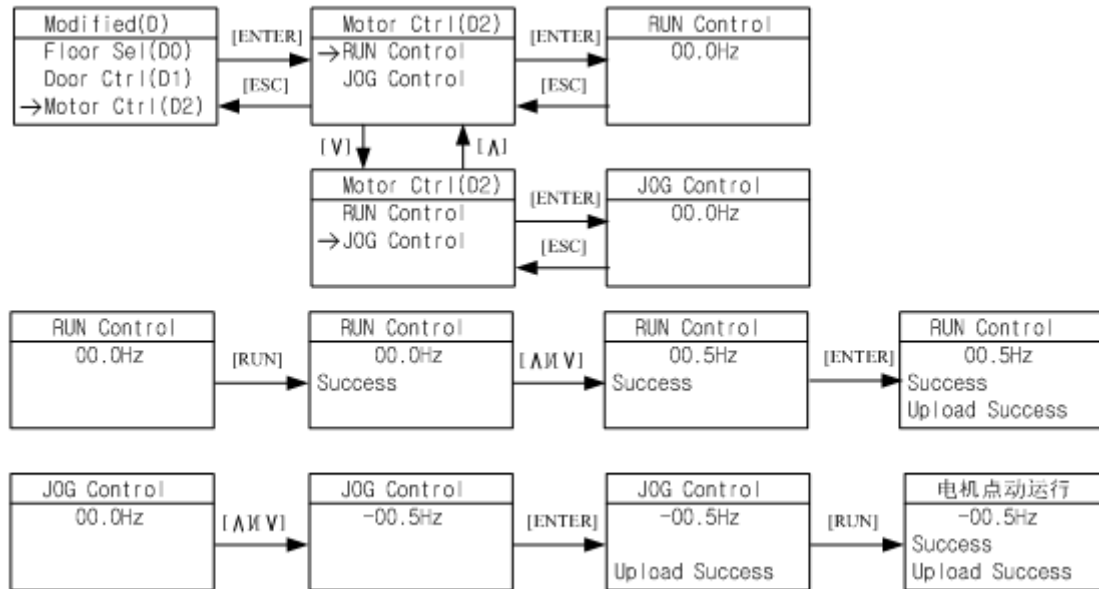

Figure 4.8 Flowchart for operator to control motor running

In interface of call testing: Press [UP]/ [DOWN] key to check the connections for all floors. Normally, it displays running success, otherwise it shows fails. Press [ESC] key to return to the Previous Menu.

The flowchart for call testing is shown in Fig 4.9

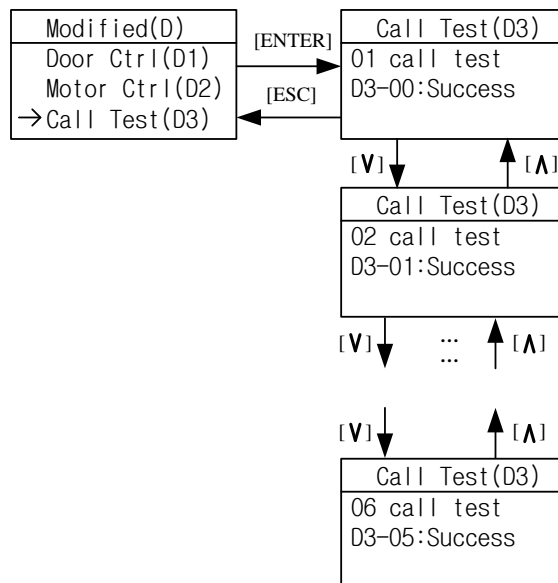

Figure 4.9 Elevator Call testing Interface

The interface of communication testing is shown in the Fig 4.10

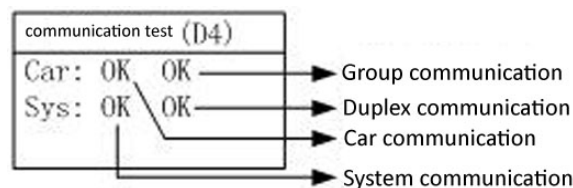

Figure 4.10 Communication Testing Interface

The display of the Car Control Communication is as follows:

- OK communication good
- ER Controller receiving data error (please check communication connection & car control board), when there appears a figure, it refers to the times of error on car control board communication.

System communication display

- OK communication good
- ET the controller sending data error (please check landing call communication connection), when there appears a figure, it refers to the times of error on system communication.

Group control communication

- OK Group control system communication good
- ER Group control system communication abnormal (When choose this option)

Duplex control communication

- OK Duplex control system communication good
- ET/ER Duplex control system communication abnormal (When choose this option)

4.5. Save Parameter

In the interface of saving parameter, press the [ENTER] to save all the parameters in the F menu. During saving process, LCD will display "Waiting"; after saving, it will display "Success" or "Failure". The flowchart of saving parameter is shown in the Fig 4.11

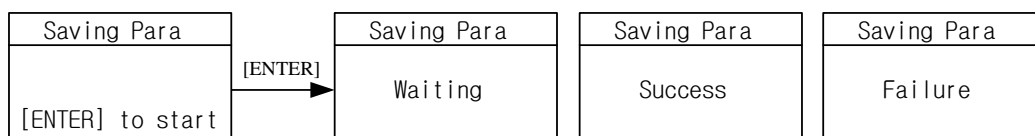
**Figure 4.11 Saving Parameter**

4.6. Hoistway Learning

In hoistway learning interface: when status display "To Down limit", the hoistway learning cannot start directly. The elevator should manual run to the down limit position first, and "To Down limit" status disappear, the screen will display "[ENTER] to start", press the [ENTER] key to start hoistway learning. During the learning process, the interface will display the current learning floor and display the status of "Waiting", when the hoistway learning is completed, the status will display "Success", when there are errors during the hoistway learning, the status will display "ERR" and display error code. Press [ESC] key to return the Previous Menu.

The flowchart of the hoistway learning is shown in the Fig 4.12.

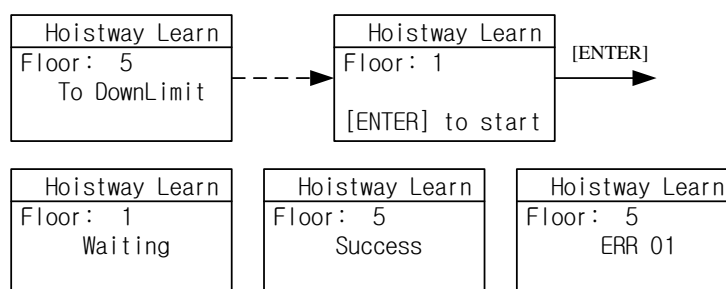
**Figure 4.12 Hoistway Learning**

4.7. Motor Auto-tuning

Motor Auto-tuning includes two parts: Motor angle tuning and motor parameter tuning. In the interface of Motor Tune: Press [UP] or [DOWN] key to move the arrow to select related tuning information; Press [ENTER] key to enter the pointed tuning interface.

In the interface of Motor Angle Tuning and Motor Parameter Tuning, press [ENTER] to start turning. During tuning, the operator display “waiting”; after tuning, it will display “success”. During tuning, if there is error, the tuning process will be terminated, and LCD will display “Tune End”, and the status is “error”, with error code followed.



Note: Before auto-tuning process, make sure to set the parameters in the F5 menu first.

Make sure motor has no load, first carry out motor parameter tuning, then carry out the motor angle tuning. Press [ESC] key to return to the previous menu. The flowchart of the motor learning is shown in Fig 4.13

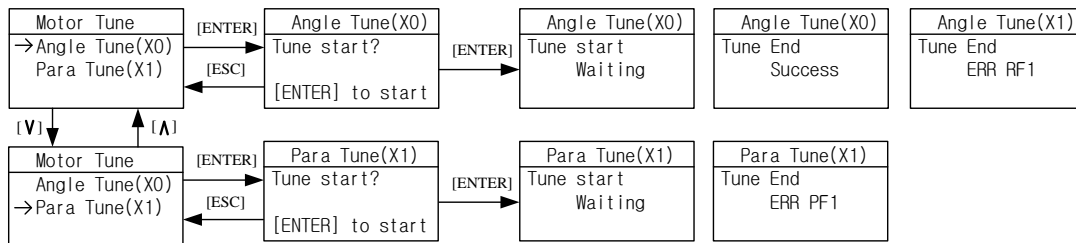

Figure 4.13 Motor Auto-Tuning process

4.8. Motor Load Tuning

Motor Load Tuning also includes two parts: Light loaded tuning and Full-loaded tuning.

In the interface of load tuning: Press [UP] or [DOWN] move the arrow to select related tuning information; press [ENTER] key to enter the pointed tuning interface.

In light-loaded tuning or full-loaded tuning interface: Press [ENTER] to start tuning process, the operator display the present status. Press [ESC] key to return to the Previous Menu.

The flowing chart of weighing learning is shown in 4.14.

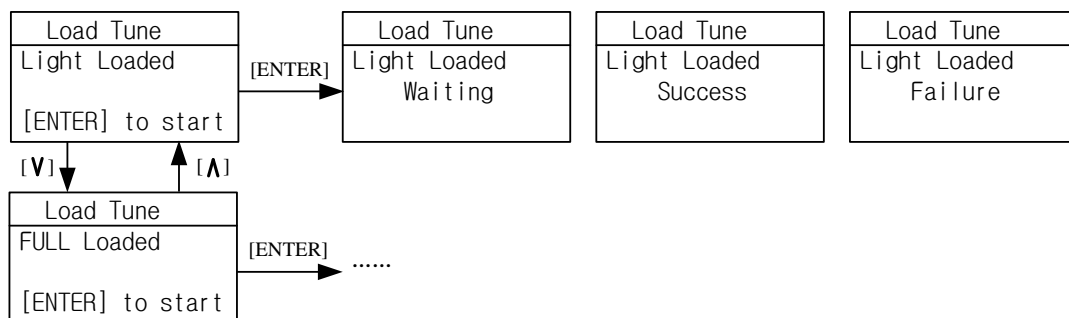

Figure 4.14 Motor Load Tuning Process

4.9. Time Setting

In the interface of time setting, the last two digit of “Year”, “month”, “day”, “hour”, “Minute” and “second” are editable, press [LEFT] or [RIGHT] to move the arrow to the right place. Press [UP] or [DOWN] key to change the pointed value. After setting: Press the [ENTER] key to save. Press [ESC] key to return the Previous Menu.

The flowchart of time setting is shown in the Fig 4.15

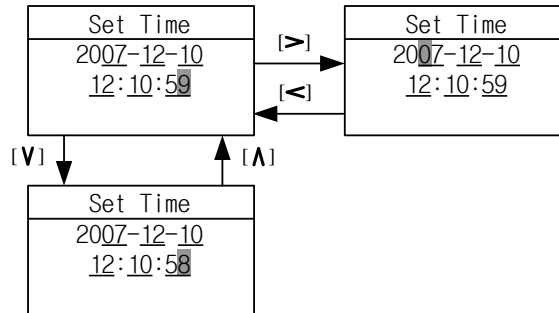

Figure 4.15 Time Setting

4.10. Fault Record Check

In the interface of Fault Record: Press [UP] or [DOWN] key to check the elevator and controller fault record. Press [ENTER] to enter the selected fault record, press [UP] or [DOWN] key to check the latest 30 fault history record.

Each elevator fault record includes error code, time, elevator status at fault (Floor number, running direction, running speed, I/O state), and related information. This helps to find the root cause of the elevator fault and guide the elevator maintenance.

Each controller fault record includes error code, time, elevator status at fault and other important data (Running speed, line/BUS voltage and current). This helps to find the root cause of the controller fault and guide the elevator maintenance.

The flowchart of the fault record check is shown in the Fig 4.16

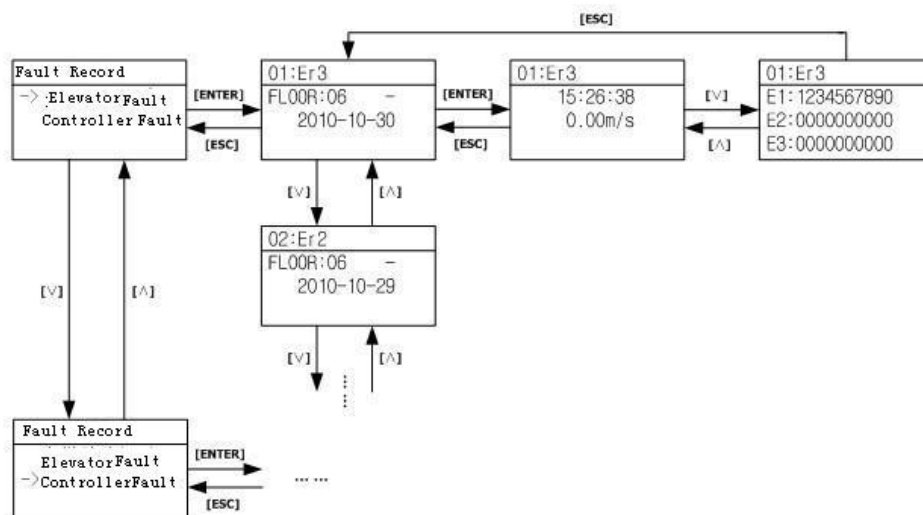

Figure 4.16 Fault Record Check

Press [ESC] key to return to the Previous Menu.

4.11. Environment Initialization

In environment initialization interface, the display language, the parameter visit grade, input password and the shortcut menu of the operator can be set.

The flowchart for environment initialization is shown in the Fig 4.17.

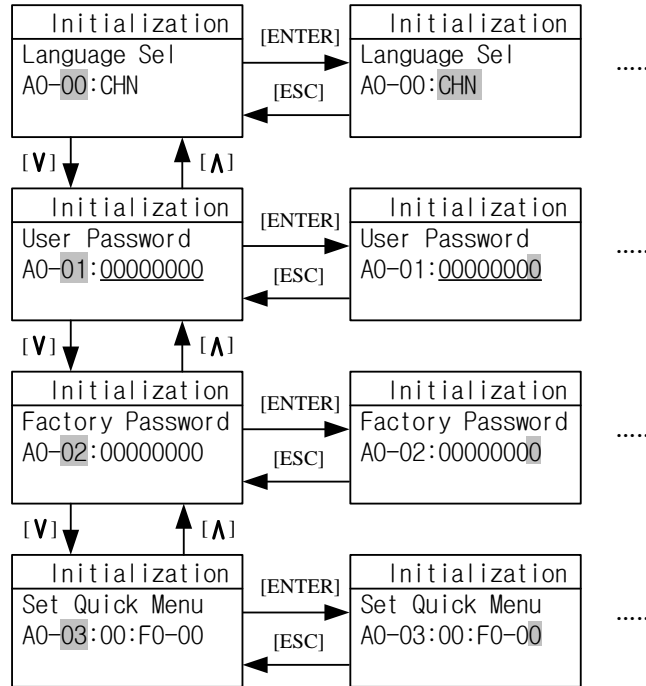

Figure 4.17 Environment Initialization

Language Selection

The flowchart for the language selection is shown in the Fig 4.18.

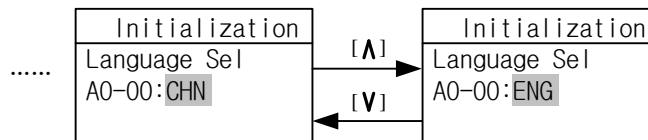

Figure 4.18 Language Selection

Press [UP] or [DOWN] to select language, and press [ENTER] key to save the selection.

User password input and setting

In the interface of password, press the [LEFT] or [RIGHT] key to move the arrow to the pointed position, press [UP] or [DOWN] key to increase or decrease the pointed value, press the [ENTER] key to input the password. When password input is incorrect, “invalid password” will be displayed, and the password cannot be changed at this time. When the password input is correct, “Password OK” will be displayed, next press [ENTER] first then press [RES] key to enter the password setting interface and reset the password. Resetting password is similar to input password. Finally press the [ENTER] key to save the new password.

The flowchart of the password input and change is shown in the Fig 4.19.

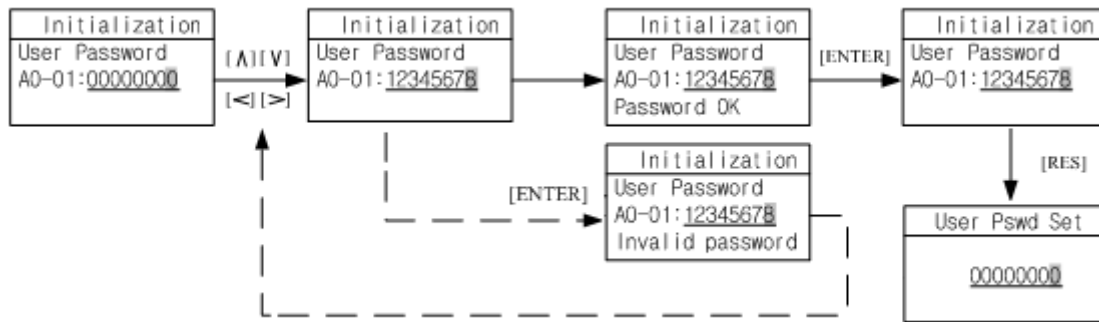

Figure 4.19 User Level Password Input/Change

Factory level password Input and Setting

The flow chart of the factory level password input and setting refers to the user level password input and setting.

Quick Menu Setting

Setting quick menu is to simplify the parameter setting and commissioning of the elevator through copying the necessary and basic elevator parameter and normal commissioning parameters to the shortcut menu. With this mechanism, only setting and modifying the parameter for the quick menu can finish the elevator running and commissioning. This avoids carrying out the parameter setting and modifying through several menus and simplifies the course of the parameter setting and commissioning.

All controllers are pre-set with default quick menu. Normally user does not need to modify this.

Set the view interface in quick menu, press [UP]/[DOWN] key to view the setting shortcut menu number, press [ENTER] key to enter editing page, press [LEFT]/[RIGHT] / [UP]/[DOWN] key to move the arrow and modify the value of every single option in the quick menu. After modifying: Press [ENTER] key to save the setting. And the system will jump to the next Set Quick Menu interface.

The flowchart for setting of the quick menu is shown in Fig 4.20

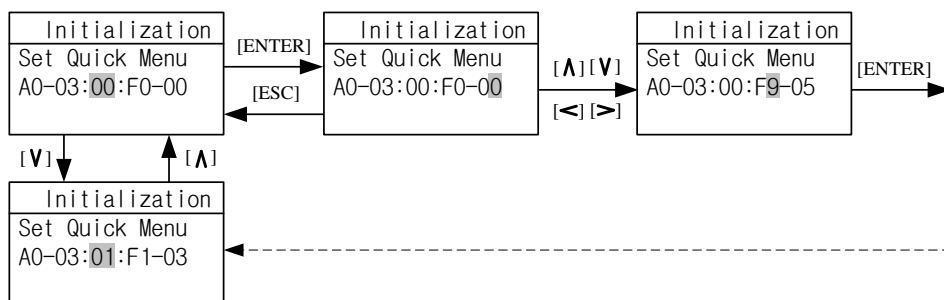

Figure 4.20 Quick Menu Setting

Press [ESC] key to return to the previous menu.

4.12. Parameter Copy

The function parameter copy is to simplify the parameter setting and commissioning process, especially for multiple elevators with same configurations. After finishing the parameter setting and commissioning of one elevator, this function can copy all the parameters (Saved in the digital operator memory), take the digital operator and connect to other elevators, copy all the parameters to the controller, check parameters, and the elevator can run normally.

In the interface of parameter copy: Press [UP] or [DOWN] key to move the arrow to carry on the necessary operation, press the [ENTER] key to start operation.

The flowchart of parameter copy is shown in Fig 4.21.

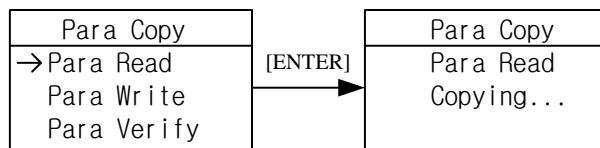

Figure 4.21 Parameter Copy

After copy operation, LCD display is shown below in Fig 4.22.

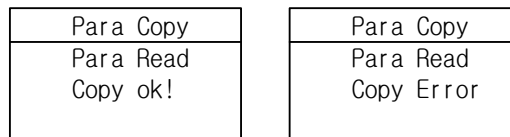

Figure 4.22 Parameter Copy Finish

Press [ESC] key to return to the previous menu.

4.13. Restore to Factory Setting

If necessary, the controller can be restored to the factory (default) setting. Press the [ENTER] key to restore the factory setting, the interface will display the status and the result.

The flow chart of restore the factory setting is shown in the Fig 4.23.

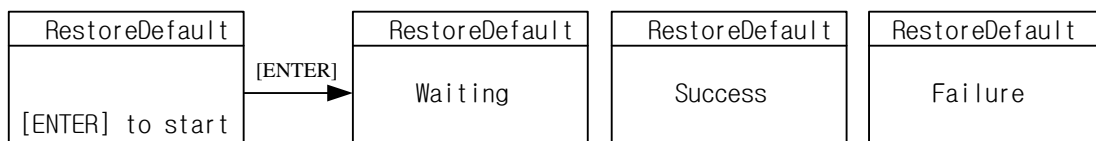

Figure 4.23 Restore to Factory Setting

Press [ESC] key to return the previous menu.

4.14. Blue-Light Traction machine Parameter Input

When using Blue-Light Integrated Controller, if the traction machine is also made by Blue-Light, you only need to input the machine model number and encoder information on the machine name plate to finish the parameter setting of the machine.

The interface of the Blue-Light machine input is showing in figure 4.24(a). The input content has three parts, separated by “.”. The first part is the model number (separated in 4 digits), the middle part is encoder resolution information, the last part is the PG model. The detail information is showing in figure 4.24(b)

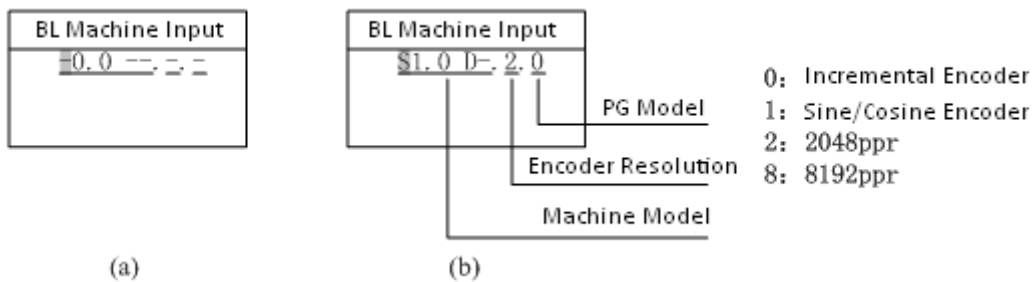

Figure 4.24 Blue-Light Machine Input

Use [UP] or [DOWN] key to set the content of the pointed area, then press the [ENTER] key to confirm. The cursor is then moved to next bit. If the pointed area is not set, the cursor will not move even you press the [ENTER] key (Except the 4th number of the machine model, e.g. S1.0D- as the last number is empty, you can press the [ENTER] key directly to set the next bit).

The flow chart of the Blue-Light machine input is shown below in figure 4.25 (S0.75D as an example)

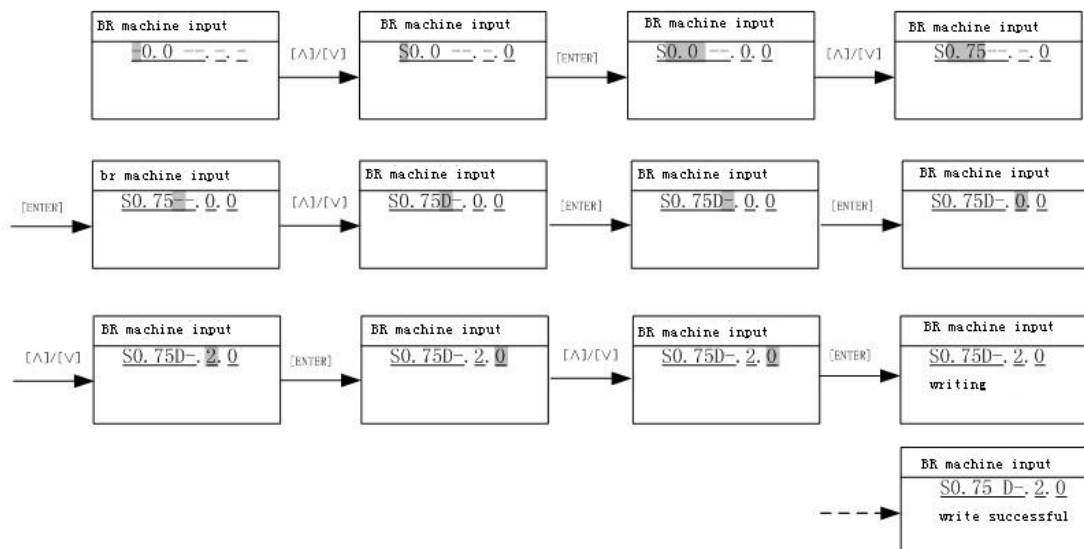

Figure 4.25 Blue-Light Machine Input Flow Chart

Chapter 5: Parameters

5.1. Parameters Function Classifications

Table 5.1 Parameter Functions List

| Function Symbol | U | F | A | D |
|-----------------|-----------------------|------------------|----------------------------|--------------------------|
| Function Name | Monitoring Parameters | Setup Parameters | Environment Initialization | Commissioning Parameters |

5.2. Parameters Hierarchical Structure

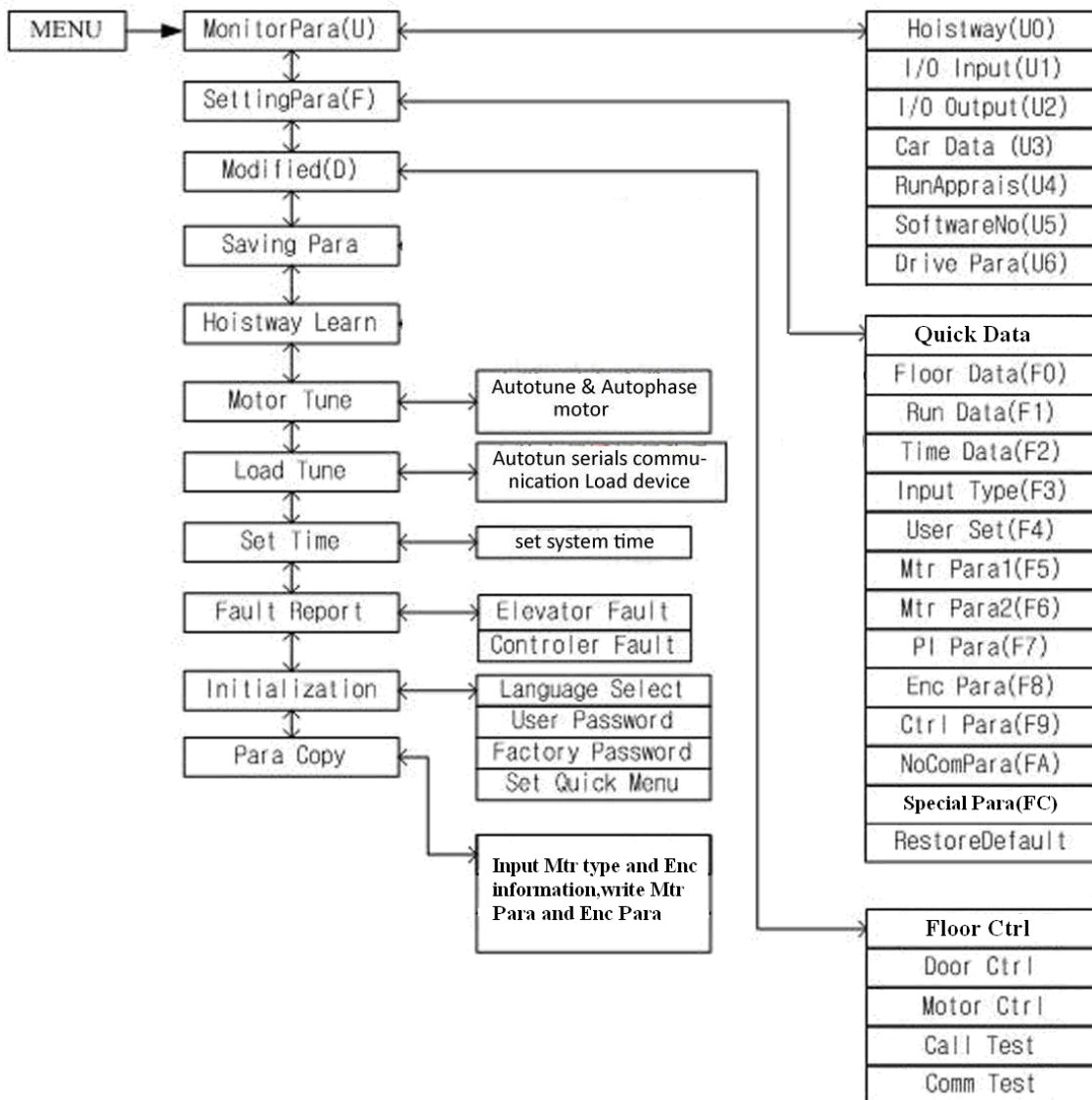

Figure 5.1 Controller Parameters Hierarchical Structure

5.3. Monitoring Parameters

5.3.1. Hoistway Location (U0)

Hoistway location parameters refer to the hoistway switches position (top/bottom terminal/limit switches) and calibration data on each floor recorded in the controller after hoistway learning process, and the unit is m (meter). If need to calculate the distance between two floors, simply minus the calibration data on these two floors.

After hoistway learning, please check the floor calibration, if the calibration value is higher than expected, it is possible that elevator's rated speed setup is higher than the actual value or elevator encoder pulse setup is smaller than the actual pulse. If the calibration value is too low, it is possible that elevator rated speed setup is lower than the actual value or its encoder pulse setup is larger than the actual pulse.

Hoistway location parameter's number, description and content are shown below in table 5.2

Table 5.2 U0 Monitoring Parameter List

| Para No. | Display (In Chinese) | Content | Range | Unit | Ref Page |
|-----------------------|---------------------------------------|---|-------|------|----------|
| | Display (In English) | | | | |
| U0-00 | 下限位刻度 | The location of bottom limit in hoistway. Data will be recorded after finishing hoistway learning | -- | m | -- |
| | Lower Limit | | | | |
| U0-01 | 上限位刻度 | The location of top limit in hoistway. Data will be recorded after finishing hoistway learning。 | -- | m | -- |
| | Upper Limit | | | | |
| U0-02 | 下端站 1 刻度 | Location of bottom terminal switch 1 in hoistway. Data will be recorded after finishing hoistway learning | -- | m | -- |
| | Lower Slowdown 1 | | | | |
| U0-03 | 下端站 2 刻度 | DO NOT HAVE BOTTOM TERMINAL 2 | -- | m | -- |
| | Lower Slowdown 2 | | | | |
| U0-04 | 上端站 1 刻度 | Location of top terminal switch 1 in hoistway. Data will be recorded after finishing hoistway learning | -- | m | -- |
| | Upper Slowdown 1 | | | | |
| U0-05 | 上端站 2 刻度 | DO NOT HAVE TOP TERMINAL 2 | -- | m | -- |
| | Upper Slowdown 2 | | | | |
| U0-06 ... U0-69 | 1 层刻度 ... 64 层刻度 Floor Data 1...64 | The location of floor 1-64 switches in hoistway. Data will be recorded after finishing hoistway learning | -- | m | -- |

5.3.2. Monitoring Parameter for I/O Status, Cabin Signal & Interference Appraisal (U1-U5)

Table 5.3 U1~U5 Monitoring Parameter List

| Para No. | Display (In Chinese) | Content | Range | Unit | Ref Page |
|----------|----------------------|--|-------|-------|----------|
| | Display (In English) | | | | |
| U1-00 | 输入状态 | Controller input data show in decimal type. It will be turned into binary type to show the logical status of the input port. | -- | -- | 3-6 |
| | Input Data | | | | |
| U1-01 | 输入状态指示 | Input port data show in binary type .Each data correspond to logical status of one input port. | -- | -- | 3-6 |
| | Input Bin | | | | |
| U1-02 | 输入状态评价 | Each line correspond to one input port, "On/Off" states the current port status, the following "n" value states the signal appraisal to input level. Value from "10" to "0" refers to interference condition from good (less interference) to bad (large interference) | -- | -- | 3-6 |
| | Input App | | | | |
| U2-00 | 输出状态 | Display the output port Y0-Y15 current status. The valid output port has the corresponded indication. Port without output (invalid) will be hidden. | -- | -- | 3-7 |
| | Output Data | | | | |
| U3-00 | 轿厢信号 | Display car input signal status. The valid input port has the corresponded indication. Port without input (invalid) will be hidden. | -- | -- | 5-5 |
| | Car Input Data | | | | |
| U4-00 | 运行次数 | Show the elevator accumulated running times. Adopts 10 digital decimal figures as indication | -- | Times | -- |
| | Run Times | | | | |
| U4-01 | 运行时间 | Show the elevator accumulated running hour. Adopts 10 digital decimal figures as indication. | -- | Hour | -- |
| | Run Hours | | | | |
| U4-04 | 并联通讯 1 | Signal send appraisal for Duplex and group control. Large number means communication send more mistakes. | -- | -- | -- |
| | SendApp1 | | | | |
| U4-05 | 并联通讯 2 | Signal receive appraisal for Duplex and group control. Large number means communication receive more mistakes. | -- | -- | -- |
| | ReceiveApp2 | | | | |
| U4-06 | 电磁干扰评价 | Appraise the value of interference strength at site. The big value refers to strong interference,"0" states no interference and good GND condition. | -- | -- | -- |
| | Interfer Apprais | | | | |
| U4-07 | 编码器评价 | The interference degree of encoder signal. When elevator runs steady, large value states the encoder signal weak with heavy interference. | -- | -- | -- |
| | Encoder Apprais | | | | |

Table 5.3 U1~U5 Monitoring Parameters List (Cont'd)

| Para No. | Display (In Chinese) | Content | Range | Unit | Ref Page |
|----------|----------------------|--|-------|------|----------|
| | Display (In English) | | | | |
| U4-09 | 锁梯计数 | The current elevator stop timer | -- | -- | -- |
| | Lock Timer | | | | |
| U5-00 | 控制软件版本 | Show the elevator control software information. Provide the current software version for factory maintenance and software upgrading. | -- | -- | -- |
| | CtrlSoftWare NO | | | | |
| U5-01 | 驱动软件版本 | Show the drive control software information. Provide the current software version for factory maintenance and software upgrading. | -- | -- | -- |
| | DriveCodeVer | | | | |
| U5-02 | 底层驱动版本 | Show base drive control software information. Provide the current software version for factory maintenance and software upgrading. | -- | -- | -- |
| | CpldEdition | | | | |



For the meaning of input status U1-01 AND output status U2-00, please refer to the control terminal definition **Table 3.3**. Cabin signal symbol definition and content is shown in **Table 5.4**.

Table 5.4 U3-00 Signal & Actual Input Comparison

| Actual Input | Signal Display | Content |
|--------------|----------------|--|
| X32 | C00 | Heat sensor Input |
| X33 | C01 | Door open Input 2 |
| X34 | C02 | Door close input 2 |
| X35 | C03 | Door interlock coil Input |
| I0 | C04 | Door open delay Input |
| I1 | C05 | Full/Single Collective: Car call 1/1 |
| I2 | C06 | Full/Single Collective: Car call 2/2 |
| I3 | C07 | Full/Single Collective: Car call 3/3 |
| I4 | C08 | Full/Single Collective: Car call 4/4 |
| I5 | C09 | Full/Single Collective: Car call 5/5 |
| I6 | C10 | Full/Single Collective: Car call 6/6 |
| I7 | C11 | Full/Single Collective: Car call 7/7 |
| I8 | C12 | Full/Single Collective: Landing call up 1/ Car call 8 |
| I9 | C13 | Full/Single Collective: Landing call up 2/ Car call 9 |
| I10 | C14 | Full/Single Collective: Landing call up 3/ Landing call 1 |
| I11 | C15 | Full/Single Collective: Landing call up 4/ Landing call 2 |
| I12 | C16 | Full/Single Collective: Landing call up 5/ Landing call 3 |
| I13 | C17 | Full/Single Collective: Landing call up 6/ Landing call 4 |
| I14 | C18 | Full/Single Collective: Landing call down 2/ Landing call 5 |
| I15 | C19 | Full/Single Collective: Landing call down 3/ Landing call 6 |
| I16 | C20 | Full/Single Collective: Landing call down 4/ Landing call 7 |
| I17 | C21 | Full/Single Collective: Landing call down 5/ Landing call 8 |
| I18 | C22 | Full/Single Collective: Landing call down 6/ Landing call 9 |
| I19 | C23 | Full/Single Collective: Landing call down 7/ Landing call 10 |

5.3.3. Drive Monitoring Parameters

Table 5.5 U6 Drive Monitoring Parameters List

| Para No. | Display (In Chinese) | Content | Range | Unit | Ref Page |
|----------|----------------------|------------------------------------|-------|------|----------|
| | Display (In English) | | | | |
| U6-00 | 功率等级 | Rated power class | -- | kW | -- |
| | Power | | | | |
| U6-01 | 给定转速 | Reference Speed | -- | RPM | -- |
| | Ref Speed | | | | |
| U6-02 | 反馈转速 | Feedback Speed | -- | RPM | -- |
| | Feedback Speed | | | | |
| U6-03 | 称重值 | The current load in % of full load | -- | % | -- |
| | Load | | | | |
| U6-04 | 直流母线电压 | DC BUS voltage | -- | V | -- |
| | DC Voltage | | | | |
| U6-05 | 输出电流 | Output Current | -- | A | -- |
| | Output Current | | | | |
| U6-06 | 变频器内部温度 | Drive internal temperature | -- | °C | -- |
| | Temperature | | | | |
| U6-07 | 输出转矩 | Output Torque | -- | N·M | -- |
| | Output Torque | | | | |

5.4. Parameters setup Function Instruction

5.4.1. Building Setup Parameters (F0)

Table 5.6 Building Setup Parameters List

| Para No. | Display (In Chinese) | Content | Range | Factory Setting | Unit | Live Change | Ref Page |
|-----------------------|-----------------------------------|--|----------------|-----------------|------|-------------|----------|
| | Display (In English) | | | | | | |
| F0-00 | 总楼层 | Total floor number (same as door zone plate number) | 2~64 | 6 | -- | N | -- |
| | Total Floor | | | | | | |
| F0-01 | 基站层 | Without landing/car call elevator will return this floor. | 1~ Total floor | 1 | -- | N | 6-8 |
| | Homing Floor | | | | | | |
| F0-02 | 消防层 | At fire-linkage circuit close, elevator enter fire mode and return to this floor automatically. | 1~ Total floor | 1 | -- | N | 6-9 |
| | Fire Floor | | | | | | |
| F0-03 | 锁梯层 | When close electric lock in the process of running, elevator return to this floor and stop. | 1~ Total floor | 1 | -- | N | 6-8 |
| | Parking Floor | | | | | | |
| F0-04 | 显示输出编码选择 | Set floor display coding. 0: 7-segment; 1: BCD code; 2: Grey code; 3: point to point; 4: Decimal. | 0~ 63 | 0 | -- | N | -- |
| | VIP Floor | | | | | | |
| F0-05 ... F0-68 | 1~64 层显示设置 Set Indication 1~64 | Set indication 1-64, customized character/figure display available | --- --- | 1 ... 64 | -- | N | 6-13 |



“N” states the parameter cannot be changed in the process of running. “Y” states the parameter can be changed in the process of running. It has same meaning in the following table.

5.4.2. Parameters for Running Setup (F1)

Table 5.7 Running Setup Parameters List

| Para No. | Display (In Chinese) | Content | Range | Factory Setting | Unit | Live Chang | Ref Page |
|----------|----------------------|--|------------------|-----------------|------|------------|-----------------|
| | Display (In English) | | | | | | |
| F1-00 | 电梯额定速度 | Elevator speed at motor rated speed. Calculate through motor rated rev, traction ratio, deceleration ratio and traction sheave diameter. | 0~4.0 | 1.6 | m/s | N | 6-1 |
| | Car Speed | | | | | | |
| F1-01 | 折算转速 | Motor speed at elevator rated speed (Calculated) | 1~9999 | 1450 | RPM | N | 6-1 |
| | Motor Speed | | | | | | |
| F1-03 | 检修运行速度 | Car running speed at inspection cannot exceed 0.6m/s based on relevant standards and regulations | 0~0.6 | 0.3 | m/s | Y | 6-1 |
| | Insp Speed | | | | | | |
| F1-04 | 启动平滑速度 | For large resistance at motor start, the starting speed can have smooth increase. The start smooth speed is invalid if set to "0". | 0~0.2 | 0.00 | m/s | Y | -- |
| | Start Speed | | | | | | |
| F1-05 | 自救运行速度 | When elevator park outside door zone due to fault, if satisfy running condition, the elevator can level to door zone with this speed. | 0.01 ~ 0.6 | 0.3 | m/s | Y | 6-1 |
| | Leveling Speed | | | | | | |
| F1-06 | 单层运行速度 | Steady speed on the lowest speed curve. | 0~1.0 | 0.5 | m/s | N | 6-2 |
| | Least Speed | | | | | | |
| F1-07 | 提前开门速度 | NO SUCH FUNCTION | 0~0.3 | 0.15 | m/s | N | Appendix 2 -III |
| | Open Door Speed | | | | | | |
| F1-08 | 再平层保护速度 | NO SUCH FUNCTION | 0~0.3 | 0.3 | m/s | N | Appendix 2 -III |
| | Relevelst Speed | | | | | | |
| F1-09 | 再平层运行速度 | NO SUCH FUNCTION | 0~0.10 | 0.05 | m/s | N | Appendix 2 -III |
| | Relevelrun Speed | | | | | | |



IMPORTANT

When elevator rated speed/ Single floor running speed is lower than 0.5m/sec, please properly decrease the acceleration B1, deceleration B2; otherwise it will affect the system calculation of current speed. When user modifies the two speed value out of limit, system will reset to the data before modification.

Table 5.8 Running Setup Parameters List (Cont'd)

| Para No. | Display (In Chinese) | Content | Range | Factory Setting | Unit | Live Chang | Ref Page |
|----------|----------------------|---|---------|-----------------|------------------|------------|----------|
| | Display (In English) | | | | | | |
| F1-10 | 加速斜率 B1 | B1 refers to the acceleration speed curve changing rate, smaller value means elevator start with smooth and gentle increase of speed. | 0.1~1.0 | 0.7 | m/s ² | N | 6-2 |
| | Acceleration B1 | | | | | | |
| F1-11 | 减速斜率 B2 | B2 refers to the deceleration speed curve changing rate, smaller value means elevator brake with smooth and gentle decrease of speed. | 0.1~1.0 | 0.7 | m/s ² | N | 6-2 |
| | Deceleration B2 | | | | | | |
| F1-12 | S 曲线 P1 | P1: Acceleration speed increase rate at beginning of elevator start; smaller value means beginning of elevator start with slow and steady movement. | 0.1~1.0 | 0.6 | m/s ³ | N | 6-2 |
| | S Curve P1 | | | | | | |
| F1-13 | S 曲线 P2 | P2: Acceleration speed decrease rate at end of elevator start; smaller value means end of elevator start with slow and steady movement. | 0.1~1.0 | 0.6 | m/s ³ | N | 6-2 |
| | S Curve P2 | | | | | | |
| F1-14 | S 曲线 P3 | P3: Deceleration speed increase rate at beginning of elevator brake; smaller value means beginning of elevator brake with slow and steady movement. | 0.1~1.0 | 0.6 | m/s ³ | N | 6-2 |
| | S Curve P3 | | | | | | |
| F1-15 | S 曲线 P4 | P4: Deceleration speed decrease rate at end of elevator brake; smaller value means end of elevator brake with slow and steady movement. | 0.1~1.0 | 0.6 | m/s ³ | N | 6-2 |
| | S Curve P4 | | | | | | |
| F1-16 | 零速阈值 | Motor speed less than set value, system considers elevator speed as zero and output brake signal. | 0~10 | 1 | RPM | Y | 6-4 |
| | Zero Speed | | | | | | |
| F1-17 | 平层调整 | Adjust differences of up/down leveling | 0~100 | 50 | mm | N | 6-13 |
| | Leveling Adj | | | | | | |
| F1-18 | 称重调整 | Normally used in synchronous machine system, compensate elevator load based on steel rope weight difference on each floor. | 0~20 | 0 | -- | Y | 6-12 |
| | Load Adj | | | | | | |



IMPORTANT

Acceleration B1, deceleration B2, S curve P1, P2, P3, P4 work together to determine the final speed curve and its trend. These parameters have internal relation with each other and are not allow to change at will. When the modified value is out of limit, the value will recover to the previous data.

Table 5.9 Running Setup Parameters List (Cont'd)

| Para No. | Display (In Chinese) | Content | Range | Factory Setting | Unit | Live Chang | Ref Page |
|----------|----------------------|--|--------|-----------------|------|------------|-------------|
| | Display (In English) | | | | | | |
| F1-21 | 驱动模式 | Selection of driving mode ,when setting "1", attendant/VIP mode close door manually; when setting "3", elevator automatically do test run ,other value is invalid. | 0~9 | 0 | -- | N | -- |
| | Drive Mode | | | | | | |
| F1-22 | 贯通门方式 | Setup rear door mode, based on customer requirements, set from mode"0" to"5". | 0~5 | 0 | -- | N | 6-9 6-10 |
| | Two Door Mode | | | | | | |
| F1-23 | 消防方式 | Three Fire modes: 1.Mode"0": Elevator run fire-mode after returning to fire floor; 2.Mode "1": Elevator stop running after returning to fire floor; 3. Mode "2": After elevator return to fire floor, depend on fire switch to run/stop in fire mode. | 0~2 | 0 | -- | N | 6-9 |
| | Fire Mode | | | | | | |
| F1-24 | 并联梯号 | Set "YES" in duplex enable. Set elevator number 0-1 in duplex; 0-7 in group control. | 0~7 | 0 | -- | N | 6-12 |
| | Parallel No. | | | | | | |
| F1-25 | 并联使能 | Elevator duplex control: 1: On 0:OFF | 0/1 | 0 | -- | Y | 6-12 |
| | Twins Control | | | | | | |
| F1-26 | 群控使能 | Elevator group control: 1:ON 0:OFF | 0/1 | 0 | -- | Y | 6-12 |
| | Group Control | | | | | | |
| F1-27 | 远程监控使能 | Remote Monitoring System: 1: On 0: Off | 0/1 | 0 | -- | Y | -- |
| | Far Monitor | | | | | | |
| F1-28 | 自动开关梯使能 | Auto parking: 1:ON 0:OFF | 0/1 | 0 | -- | Y | 6-8 |
| | Auto Parking | | | | | | |
| F1-29 | 称重使能 | Load Weighing: 1:ON 0: OFF | 0/1 | 0 | -- | Y | 6-12 |
| | Load Enable | | | | | | |
| F1-30 | 开门延长使能 | Door open/close delay: 1:ON 0:OFF | 0/1 | 0 | -- | Y | 6-8 |
| | Open Delay Able | | | | | | |
| F1-31 | 闸臂反馈使能 | Test brake feedback signal: 1: open 2: close | 0/1 | 0 | -- | Y | 6-4 |
| | Brake Feedback | | | | | | |
| F1-32 | 解梯密码 | NOT VALID | 0~9999 | 0 | -- | N | -- |
| | Rerun Password | | | | | | |

5.4.3. Time Setup Parameters (F2)

Table 5.10 Time Setup Parameters List

| Para No. | Display (In Chinese) | Content | Range | Factory Setting | Unit | Live Chang | Ref Page |
|----------|----------------------|--|-----------|-----------------|------|------------|----------|
| | Display (In English) | | | | | | |
| F2-00 | 提前开闸时间 | Brake open first then run elevator speed curve. This is to improve the elevator start comfort and match control system with different machine brake on time. | 0.00~9.99 | 0.50 | s | Y | 6-4 |
| | Brake ON Time | | | | | | |
| F2-01 | 抱闸时间 | Brake close first then disable elevator run. This is to improve elevator stop comfort and avoid slip at elevator stop. | 0.00~9.99 | 0.50 | s | Y | 6-4 |
| | Brake OFF Time | | | | | | |
| F2-02 | 检修抱闸时间 | The time delay in inspection mode before brake close. | 0.00~9.99 | 0.05 | s | Y | 6-4 |
| | Insp Brake Time | | | | | | |
| F2-04 | 零速时间 | The time delay when system detects elevator stop. Adjust this parameter to close brake after elevator reach 0 speed completely, increase elevator stop comfort. | 0~9.99 | 0.30 | s | Y | 6-4 |
| | Zero Time | | | | | | |
| F2-05 | 开门保持时间 | In Auto mode, elevator automatically open door when stopping at one floor, door will automatically close after set time. | 0~999 | 3 | s | Y | 6-7 |
| | Open Door Time | | | | | | |
| F2-06 | 开门延长时间 | Enable door open delay function, press open delay button, door open time will be delayed. | 0~999 | 30 | s | Y | 6-7 |
| | Open Delay Time | | | | | | |
| F2-07 | 返基站时间 | The waiting time before elevator return to homing floor without landing/car call, Set value to "0" to disable this function. | 0~999 | 60 | s | Y | 6-8 |
| | Homing Time | | | | | | |
| F2-08 | 开关门保持时间 | 1. The door open/close command run time; 2. Door open/close relay run time for door drive without open/close limit switch. 3. For door drive with open/close limit switch, this run time should be 1s longer than the door actual open/close time. | 0~999 | 5 | s | Y | 6-7 |
| | Door Run Time | | | | | | |

Table 5.10 Time setup Parameters List (Cont'd)

| Para No. | Display (In Chinese) | Content | Range | Factory Setting | Unit | Live Chang | Ref Page |
|----------|----------------------|---|-----------------------|-----------------|------|------------|----------|
| | Display (In English) | | | | | | |
| F2-09 | 到站信号延时 | After elevator change speed to target floor, landing signal is delayed by set time, arrival gong /voice synthesizers are also delayed by set time. | 0.00~9.99 | 0.15 | s | Y | -- |
| | Beep Delay Time | | | | | | |
| F2-10 | 使能延时 | Drive enable signal given/drop is delayed by set time after drive direction signal is given/drop. During this time, drive output current is decreased to reduce current noise. | 0.00~9.99 | 0 | s | Y | 6-4 |
| | Enable Delay | | | | | | |
| F2-11 | 关照明延时 | In Auto mode, if have no car/landing call during set time, system will cut car light power from COP. | 0~999 | 15 | min | Y | -- |
| | Lamp Off Time | | | | | | |
| F2-12 | 运行超时时间 | To prevent wire rope slipping or elevator car stuck, time from elevator running to stop is limited to set value. If elevator is running longer than set value, system stops immediately and enter protection mode. Need to re-start the system in order to exit from such mode. | 0~999 | 45 | s | Y | -- |
| | Over Time | | | | | | |
| F2-13 | 启动平滑时间 | The time to keep elevator start smooth. | 0.00~9.99 | 0 | s | Y | 6-4 |
| | SmoothStart Time | | | | | | |
| F2-14 | 自动开梯时间 | System will automatically start the elevator (Electric lock: ON) at set time. | 00:00 ... 23:59 | 00:00 | 时:分 | Y | 6-8 |
| F2-15 | Start Time | | | | | | |
| F2-16 | 自动关梯时间 | System will automatically stop the elevator (Electric lock: OFF) at set time. This function is disabled if same start/stop time. | 00:00 ... 23:59 | 00:00 | 时:分 | Y | 6-8 |
| F2-17 | Stop Time | | | | | | |
| F2-18 | 不停层开时间 | System will run bypass the set floor start from this time. | 00:00 ... 23:59 | 00:00 | 时:分 | Y | |
| F2-19 | Start Time1 | | | | | | |
| F2-20 | 不停层关时间 | System will run bypass the set floor start until this time. | 00:00 ... 23:59 | 00:00 | 时:分 | Y | |
| F2-21 | Stop Time1 | | | | | | |



The elevator automatic switch: F2-14, F2-15 F2-16, F2-17 were set separately as per hours and minutes. Please follow the operator indication for this setting.

5.4.4. Input type setup Parameters (F3)

Table 5.11 Input Type Setup Parameters List

| Para No. | Display (In Chinese) | Content | Range | Factory Setting | Live Chang | Ref Page |
|----------|----------------------|--|----------------------|-----------------|------------|--------------|
| | Display (In English) | | | | | |
| F3-00 | 主板输入类型 | Setting the input type on main control panel. Each bit corresponds to one terminal. Set default level of main board input port. ON: Close enable, OFF: Open enable. | 0~ 42949672 95 | 3974102 631 | N | 6-10 6-11 |
| | Input Type | | | | | |
| F3-01 | 轿厢输入类型 | Setting the input type of cabin. Each bit corresponds to one terminal. ON: Close enable, OFF: Open enable. Point correspond to X32-X35, I0-I19. | 0~ 42949672 95 | 4294573 839 | N | 6-10 6-11 |
| | Car Input Type | | | | | |
| F3-02 | 输入功能 1 | X12 Input Function Selection | 0~32 | 12 | N | |
| | Input select 1 | | | | | |
| F3-03 | 输入功能 2 | X18 Input Function Selection | 0~32 | 18 | N | |
| | Input select 2 | | | | | |
| F3-04 | 输入功能 3 | X27 Input Function Selection | 0~32 | 27 | N | |
| | Input select 3 | | | | | |
| F3-05 | 输入功能 4 | NO SUCH FUNCTION | 0~32 | 24 | N | |
| | Input select 4 | | | | | |
| F3-06 | 输入功能 5 | NO SUCH FUNCTION | 0~32 | 25 | N | |
| | Input select 5 | | | | | |
| F3-07 | 输出功能 1 | NO SUCH FUNCTION | 0~32 | 0 | N | |
| | output select 1 | | | | | |
| F3-08 | 输出功能 2 | NO SUCH FUNCTION | 0~32 | 11 | N | |
| | output select 2 | | | | | |
| F3-09 | 输出功能 3 | NO SUCH FUNCTION | 0~32 | 12 | N | |
| | output select 3 | | | | | |



When using X22 and X23 as multifunctional input port, please make sure the re-leveling device is NOT used.

5.4.5. Service Setup Parameters (F4)

Table 5.12 Service Setup Parameters List

| Para No. | Display (In Chinese) | Content | Range | Factory Setting | Live Chang | Ref Page |
|----------|----------------------|---|----------------------|----------------------------|------------|----------|
| | Display (In English) | | | | | |
| F4-00 | 不停层设置 1 | Set elevator stop/bypass at floor corresponds to each bit. (1-32 floors) | 0~ 429496729 5 | 4294967 295 | Y | 6-12 |
| | Set Stop Floor1 | | | | | |
| F4-01 | 不停层设置 2 | Set elevator stop/bypass at floor corresponds to each bit. (33-64floors) | 0~ 429496729 5 | 4294967 295 | Y | 6-12 |
| | Set Stop Floor2 | | | | | |
| F4-02 | 分时不停层 1 | Set elevator stop/bypass at floor corresponds to each bit at the set time. (1-32 floors) | 0~ 429496729 5 | 0 | Y | 6-12 |
| | TIM Stop Floor1 | | | | | |
| F4-03 | 分时不停层 2 | Set elevator stop/bypass at floor corresponds to each bit at the set time. (33-64 floor) | 0~ 429496729 5 | 0 | Y | 6-12 |
| | TIM Stop Floor2 | | | | | |
| F4-04 | 前门设置 1 | Set elevator front door enable /disable at floor corresponds to each bit (ON/OFF: Front door enable /disable at this floor) | 0~ 429496729 5 | 4294967 295(1~ 32 层) | Y | 6-10 |
| | Door Select A1 | | | | | |
| F4-05 | 后门设置 1 | Set elevator rear door enable /disable at floor corresponds to each bit (ON/OFF: Rear door enable /disable at this floor) | 0~ 429496729 5 | 4294967 295(1~ 32 层) | Y | 6-10 |
| | Door Select B1 | | | | | |
| F4-06 | 特殊功能选择 | Set elevator functions enable /disable at floor corresponds to each bit. (ON: Enable, OFF: Disable) | 0~ 429496729 5 | 4 | Y | 6-13 |
| | Function Select | | | | | |
| F4-07 | 特殊功能选择 2 | Set elevator functions enable /disable at floor corresponds to each bit. (ON: Enable, OFF: Disable) | 0~ 429496729 5 | 0 | Y | 6-13 |
| | Function Select 2 | | | | | |

5.4.6. Motor Setup Parameters (F5-F6)

Table 5.13 Motor Setup Parameters List

| Para No. | Display (In Chinese) | Content | Range | Factory Setting | Unit | Live Chang | Ref Page |
|----------|----------------------|---|------------------------|-----------------|------|------------|----------|
| | Display (In English) | | | | | | |
| F5-00 | 电机类型 | Set motor type (0:sync- outer rotor, 1:async machine, 2:sync-inner rotor) | 0~2 | 0 | -- | N | 6-14 |
| | Motor Type | | | | | | |
| F5-01 | 电机极数 | Moto poles (Nameplate) | 1~99 | 20 | -- | N | 6-14 |
| | Poles | | | | | | |
| F5-02 | 电机同步频率 | Motor synchronous frequency (Nameplate) | 0.001~99.99 | 16 | Hz | N | 6-14 |
| | Sync Freq | | | | | | |
| F5-03 | 电机额定功率 | Motor rated power (Nameplate) | 1~50 | 6.7 | kW | N | 6-14 |
| | Rated Power | | | | | | |
| F5-04 | 电机额定转速 | Motor rated speed (Nameplate) | 1~1999 | 96 | RPM | N | 6-14 |
| | Rated Speed | | | | | | |
| F5-05 | 反电动势 | Motor counter-EMF (Nameplate) | 1~380 | 280 | V | N | 6-14 |
| | V IN | | | | | | |
| F5-06 | 电机相电感 | Motor phase inductance set. (Auto-tuning/ manual input) | Auto-tuning /Nameplate | | mH | N | 6-14 |
| | L_phase | | | | | | |
| F5-07 | 电机相电阻 | Motor phase resistance set. (Auto-tuning/ manual input) | Auto-tuning /Nameplate | | Ω | N | 6-14 |
| | R_phase | | | | | | |
| F5-08 | 电机额定电流 | Motor rated current. (Nameplate) | 0~99.999 | | A | N | 6-14 |
| | Rated FLA | | | | | | |
| F5-09 | 空载电流 | For asynchronous machine, no-load excitation current. | 0.1~50 | 0 | A | N | 6-14 |
| | NO-Load Current | | | | | | |
| F5-10 | 滑差 | For asynchronous machine rated slip. (Nameplate) | 0.1~10 | 1.3 | HZ | N | 6-14 |
| | Rated Slip | | | | | | |
| F6-00 | 载波频率 | Set controller carrier frequency. | 6~15 | 8 | kHz | N | -- |
| | Carrier Freq | | | | | | |
| F6-02 | 速度压缩比 | Speed Zoom (Reduce elevator actual running speed) | 0~100 | 100 | % | Y | 6-14 |
| | SpeedZoom | | | | | | |
| F6-03 | 运行方向选择 | Select motor running direction (0/1: Motor rotates anti-clockwise, car move down/up). | 0/1 | 0 | -- | -- | 6-14 |
| | DirSel | | | | | | |
| F6-04 | 速度环比例 | Speed loop proportional gain. (Valid for complete curve if not used in multiple PI.) | 0~65535 | 700 | -- | -- | 6-15 |
| | Kp | | | | | | |
| F6-05 | 速度环积分 | Speed loop integral gain. (Valid for the complete curve if not used in multiple PI.) | 0~65535 | 260 | -- | -- | 6-15 |
| | KI | | | | | | |

5.4.7. Multiple PI Setup Parameters (F7)

Table 5.14 Multiple PI Setup Parameters List

| Para No. | Display (In Chinese) | Content | Range | Factory Setting | Unit | Live Chang | Ref Page |
|----------|----------------------|--|------------------|-----------------|------|------------|----------|
| | Display (In English) | | | | | | |
| F7-00 | 多段 PI 使能 | Multiple PI parameters 1: Enable; 0: Disable | 0/1 | 0 | -- | N | 6-15 |
| | PIMulEnable | | | | | | 6-16 |
| F7-01 | PI 作用范围 1 | PI available range 1 (Start -middle speed running PI switch frequency) | 0~ Rated freq | 0 | Hz | Y | 6-15 |
| | PI1 Range | | | | | | 6-16 |
| F7-02 | PI 作用范围 2 | PI available range 2 (middle -high speed running PI switch frequency) | 0~ Rated freq | 0 | Hz | Y | 6-15 |
| | PI2 Range | | | | | | 6-16 |
| F7-04 | PI 作用范围 4 | PI available range 4 | 0~ Rated freq | 0 | Hz | Y | 6-15 |
| | PI3 Range | | | | | | 6-16 |
| F7-05 | 比例增益 1 | PI available range 1 proportional gain | 0~2000 | 700 | -- | Y | 6-15 |
| | Kp1 | | | | | | 6-16 |
| F7-06 | 积分增益 1 | PI available range 1 integral gain | 0~2000 | 260 | -- | Y | 6-15 |
| | Kx1 | | | | | | 6-16 |
| F7-07 | 比例增益 2 | PI available range 2 proportional gain | 0~2000 | 0 | -- | Y | 6-15 |
| | Kp2 | | | | | | 6-16 |
| F7-08 | 积分增益 2 | PI available range 2 integral gain | 0~2000 | 0 | -- | Y | 6-15 |
| | Kx2 | | | | | | 6-16 |
| F7-11 | 减速段比例 | PI available range 4 proportional gain | 0~2000 | 700 | -- | Y | 6-15 |
| | Kp3 | | | | | | 6-16 |
| F7-12 | 减速段积分 | PI available range 4 integral gain | 0~2000 | 260 | -- | Y | 6-15 |
| | Kx3 | | | | | | 6-16 |

5.4.8. Encoder Setup Parameters (F8)

Table 5.15 Encoder Setup Parameters List

| Para No. | Display (In Chinese) | Content | Range | Factory Setting | Unit | Live Chang | Ref Page |
|----------|----------------------|---|----------|-----------------|------|------------|----------|
| | Display (In English) | | | | | | |
| F8-00 | 编码器线数 | The encoder pulse count per-revolution. | 100~8192 | 8192 | -- | N | 6-18 |
| | Encoder PPR | | | | | | |
| F8-02 | PG 类型 | PG card type (0: Incremental encoder, 1: Sine/Cosine encoder) | 0/1 | 0 | -- | N | 6-18 |
| | PGType | | | | | | |

5.4.9. Control Setup Parameters (F9)

Table 5.16 Control Setup Parameters List

| Para No. | Display (In Chinese) | Content | Range | Factory Setting | Unit | Live Chang | Ref Page |
|----------|----------------------|--|----------|-----------------|------|------------|----------|
| | Display (In English) | | | | | | |
| F9-00 | 最大补偿力矩 | Maximum torque compensation (torque required to compensate at no load, 100% correspond to machine rated torque.) | 0~100% | 0 | % | N | 6-17 |
| | Max Torq Comp | | | | | | |
| F9-01 | 速度来源选择 | Speed given source selection: 0: Simulation; 1: Multi-segment 2: Internal; 3: Operator | 0~3 | 2 | | N | 6-14 |
| | SPDSourceSel | | | | | | |
| F9-03 | 超差范围设定 | Speed Deviation Set (100% correspond to machine rated speed.) | 0~100 | 5 | % | Y | -- |
| | Spderr Set | | | | | | |
| F9-11 | 补偿使能 | Load Compensation: 1 enable; 0 Unable | 0/1 | 1 | -- | N | 6-17 |
| | Load Comp Enable | | | | | | |
| F9-13 | 称重来源 | Weighing source (0:SJT weighing, 1:-10-10V weighing, 2:0-10V weighing) | 0/1/2 | 0 | -- | N | 6-17 |
| | Load Source Sel | | | | | | |
| F9-19 | 顺时针补偿偏置 | Up direction (clockwise) Compensation Bias | -100~100 | 0 | -- | Y | -- |
| | UP Comp Bias | | | | | | |
| F9-20 | 逆时针补偿偏置 | Down direction (anti-clockwise) Compensation Bias | -100~100 | 0 | -- | Y | -- |
| | DOWN Comp Bias | | | | | | |
| F9-21 | 满载补偿比例 | Full load compensation proportion | 0~200 | 100 | -- | Y | -- |
| | FULL Comp Pro | | | | | | |

5.4.10. No-load Compensation Setup Parameters (FA)

Table 5.17 No-load Compensation Setup Parameters List

| Para No. | Display (In Chinese) | Content | Range | Factory Setting | Unit | Live Chang | Ref Page |
|----------|----------------------|--|---------|-----------------|------|------------|----------|
| | Display (In English) | | | | | | |
| FA-00 | 启动段比例增益 | Start-up proportional gain with no compensation. | 0~50000 | 30 | -- | N | 6-19 |
| | StratKP | | | | | | |
| FA-01 | 启动段积分增益 | Start-up integral gain with no compensation | 0~50000 | 750 | -- | N | 6-19 |
| | StratKI | | | | | | |
| FA-08 | 无补偿比例 1 | No compensation effect proportional gain 1 | 1~6500 | 3600 | -- | N | 6-19 |
| | PLKP1 | | | | | | |
| FA-09 | 无补偿作用时间 | No compensation effect time | 1~1000 | 900 | ms | N | 6-19 |
| | PLTime | | | | | | |
| FA-11 | 无补偿比例 2 | No compensation effect proportional gain 2 | 0~50000 | 800 | -- | N | 6-19 |
| | PLKP2 | | | | | | |
| FA-12 | 无补偿比例系数 | No compensation effect proportional factor | 0~50000 | 125 | -- | N | 6-19 |
| | PLKPMOD | | | | | | |

5.4.11. Special Parameters (FC)

Special parameters (FC) are mapping a part of factory parameters (FX) in customer level; users can access this part information by user level password. In these parameters, FC-00~FC-06 can only be viewed but not editable, while other parameters can be changed. Special parameters (FC) number, description and content are shown below in table 5.18.

Table 5.18 Special Parameters List

| Para No. | Display (In Chinese) | Content | Range | Factory Setting | Unit | Live Chang | Ref Page |
|----------|----------------------|---|---------|-----------------|------|------------|----------|
| | Display (In English) | | | | | | |
| FC-00 | Z 脉冲数 | Result of motor angle tuning, same as FX-00. | 0~3277 | -- | -- | N | -- |
| | Zpulse_Init | | | | | | |
| FC-07 | 电流环比例 | Current ring proportional (FX-07), MODIFY WITH CAUTION! | 0~65535 | 2000 | -- | N | -- |
| | Kplreg | | | | | | |
| FC-08 | 电流环积分 | Current ring integral (FX-08), MODIFY WITH CAUTION! | 0~65535 | 500 | -- | N | -- |
| | Kxlreg | | | | | | |
| FC-13 | 自学习方式选择 | Sine/Cosine PG card auto-tuning selection (FX-20): 0:Rotation; 1:Stationary; | 0/1 | 0 | -- | N | -- |
| | AutoTuneModeSel | | | | | | |
| FC-14 | 负温度报警使能 | Negative temperature alarm (FX-21) 1: Alarm enable at -15C; 0: Alarm disable at -15C. | 0/1 | 1 | -- | N | -- |
| | N Temp Alarm Ena | | | | | | |
| FC-15 | 初始定位使能 | When using Sine/Cosine PG card, whether need CD signal for position at power up 0:Yes.1:No (Can only set to 0 for SPG-V33 and above) Set to 0 can avoid electric noise at first power up. | 0/1 | 0 | | N | FX-24 |
| | InitTuneEnable | | | | | | |
| FC-16 | CD 信号方向选择 | FC15 is available if set to 1. Set to 0 if AB & CD signal in same phase, otherwise set to 1. (Auto selected at motor angle tuning.) | 0/1 | 0 | | N | FX-25 |
| | CD DirSel | | | | | | |

5.4.12. Environment Setup Parameters (A)

Table 5.20 Environment Setup Parameters List

| Para No. | Display (In Chinese) | Content | Range | Factory Setting | Unit | Live Chang | Ref Page |
|----------|----------------------|--------------------------------------|---------------|-----------------|------|------------|----------|
| | Display (In English) | | | | | | |
| A0-00 | 显示语言 | Language selection | -- | CHINESE | -- | Y | -- |
| | Language Sel | | | | | | |
| A0-01 | 用户密码 | Input/Setting user level password | 000000~999999 | 000000 | -- | Y | -- |
| | User Password | | | | | | |
| A0-02 | 厂家密码 | Input/setting factory level password | 000000~999999 | 0000000 | -- | Y | -- |
| | Factory Password | | | | | | |
| A0-04 | 对比度 | Setting the LCD contrast level | 0~10 | 5 | -- | N | -- |
| | Contrast | | | | | | |

Chapter 6: Parameters Setup

6.1. Elevator Running Speed Setup

6.1.1. Elevator Rated Speed, Motor Rated Speed, Encoder pulses Setup

1. Elevator rated speed (F1-00) can be calculated through motor RPM, traction ratio, reduction ratio and traction sheave diameter.



Elevator rated speed is used for calculating the ratio between motor rated speed and elevator speed, modifying this parameter cannot change the actual running speed of elevator; if need to change elevator running speed, please modify parameter F6-02 (Speed Zoom)

2. Motor rated speed (F1-01) is the speed of traction machine (RPM) under elevator rated speed.
3. Encoder Pulse (F1-02) is the pulse number of encoder for hoistway counting at elevator running.
4. Motor rated speed and elevator rated speed much follow the condition below:

$$\text{Elevator rated speed} = \frac{\text{Motor RPM} \times \text{traction sheave diameter} \times 3.14 \times \text{speed reduction ratio}}{60 \times 1000 \times \text{traction ratio}}$$

For example: Motor rated speed is 1370 rev/min., traction sheave diameter 590mm, speed reduction ratio: 2/53, traction ratio 1/1, then:

$$\text{elevator rated speed} = \frac{1370 \times 590 \times 3.14 \times 2}{60 \times 1000 \times 1 \times 53} = 1.6\text{m/s}$$

After setting elevator rated speed, motor rated speed, encoder pulse number, system record the relationships between traction ratio, speed reduction ratio, traction sheave diameter and relationships between shaft counting pulse and running distance. If the setting is incorrect, the following problems may happen:

1. The elevator running speed on digital operator or software is different with the elevator actual running speed. For example, if encoder pulse or motor rated speed is set to a smaller value, speed indicated on the display will be higher than actual speed, after hoistway learning, floor height learned by the system will be larger than actual height.
2. As the floor height learned by the system is higher, the elevator deceleration curve will be steeper than the setting. This could result elevator cannot leveling sometimes (running out of leveling zone with sudden brake).

6.1.2. Inspection Run Speed

In inspection mode, elevator runs in slow inspection speed (F1-03), based on international standard, such speed should be no more than 0.6m/s. After elevator reaches top or bottom terminal, the running speed will be reduced to half of the inspection speed.

If bottom/top terminal (X8/X7) is valid, elevator slow down to 1/2 inspection speed to prevent exceeding the limit. When up/down jogging is removed, speed given will be instantly 0 without deceleration curves.

6.1.3. Rescue Speed

Under two conditions will elevator run in rescue speed (F1-05):

1. Due to fault or other reasons, elevator stops outside leveling zone, after elevator restores, it runs in rescue speed to the nearest floor and open door to release passengers;
2. When there is a hoistway counting error (ER14, Er18), elevator will run at rescue speed to the bottom floor for recalibration; After elevator reaches the bottom terminal, elevator will run at 1/2 of rescue speed to the bottom leveling position.

6.1.4. Least Speed

Least speed curve (F1-06) limits the lowest speed generated in the system. System will choose the elevator speed based on running distance, but the lowest speed is limited here. For certain site with very small floor distance, reduce this value could achieve normal running on this floor. Otherwise elevator cannot park at small distance floor, it will stop at the next floor.

6.2. Normal Running Speed Curve

Elevator can generate several optimal running curves based on rated speed setting to suit for different speed/distance running. But note lowest running speed curve is limited by F1-06.

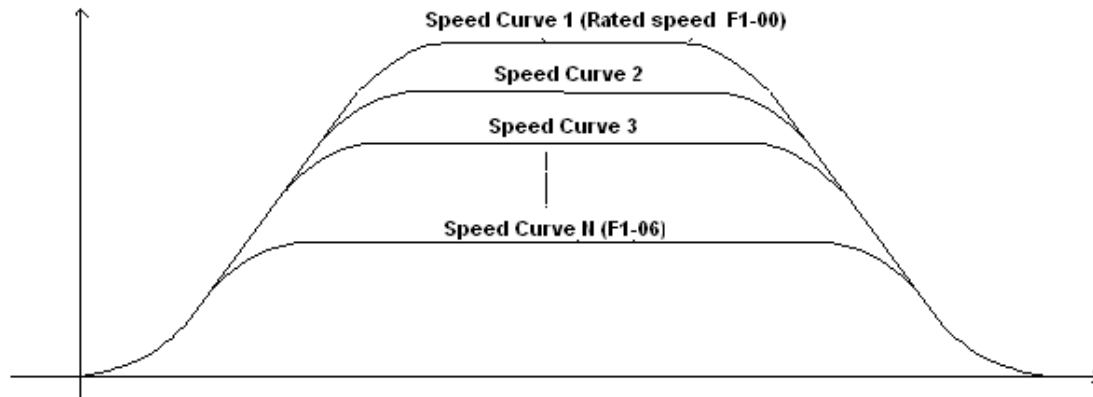

Figure 6.1 Elevator Running Speed Curve

Acceleration, deceleration for normal running curve and Acce/Dece for S curve are set by the following parameters:

- F1-10 (Acceleration B1)
- F1-11 (Deceleration B2)
- F1-12 (S curve P1)
- F1-13 (S curve P2)
- F1-14 (S curve P3)
- F1-15 (S curve P4)

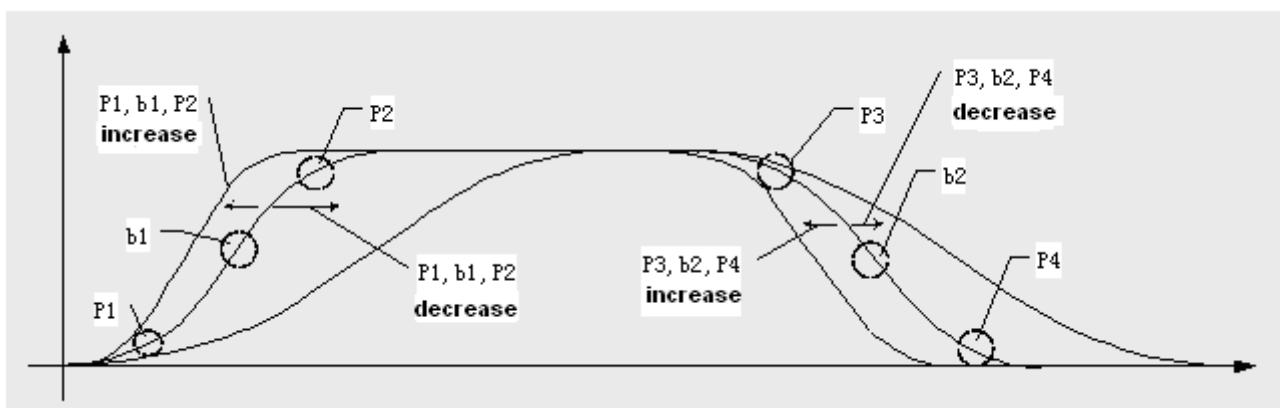

Figure 6.2 Parameters Adjustments for Speed Curve

◇ Elevator running comfort level can be set through the above 6 parameters. (Comfort level is also related to the drive control parameters.)

The relationship between **b1, b2, P1, P2, P3, P4** and running curve are shown in Fig. 6.2.

◇ Increase parameters value, the corresponded curve will be steeper. While decreasing value will smooth the corresponded curve. Adjusting the above six parameters properly can reach good comfort level at elevator running, and meet the related standard.

6.3. Elevator Running Timing Diagram

6.3.1. Timing Diagram for Normal Running

The timing diagram for normal running is shown below in Fig. 6.3

If smooth start running speed (F1-04) is set to "0", smooth start running function will be disabled; smooth start time (F2-13) will be disabled too.

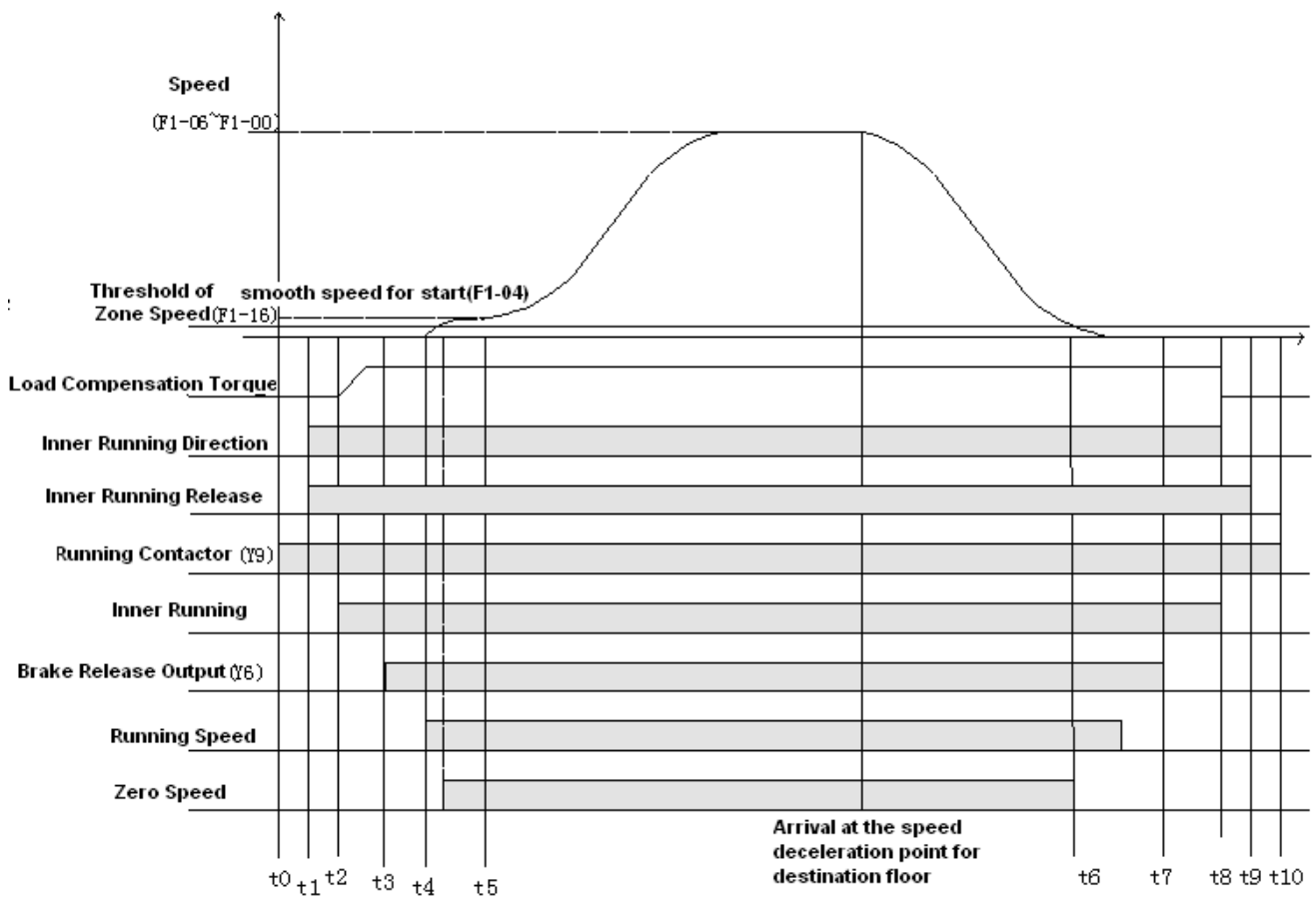

Figure 6.3 Elevator Timing Diagram for Normal Running

图

Detail explanation of timing diagram for elevator normal running is explained below in Table 6.1

Table 6.1 Timing definition for Elevator Normal Running

| Time | Definition and Setup Instruction |
|--------|---|
| t0~t1 | Control system will first output running contactor (Y9) command; check for feedback time, if valid then system will give running direction and enable driving control based on the given direction. |
| t1~t2 | Driving module output torque. |
| t2~t3 | Waiting time for internal running signal (F2-03): In this period, driving module complete motor excitation or finish load compensation torque output. |
| t3~t4 | Brake advance release time (F2-00): System output brake release command (Y6), brake release and brake arm feedback valid (e.g. F1-31=1), waiting for brake advance release time (F2-00), and then running speed is given. Two functions for brake advance release time (F2-00): 1. Brake has enough time to release completely; this can avoid elevator startup with brake. 2. After brake release, traction sheave may rotate due to the load, with enough time traction sheave can be steady at zero speed then start in order to achieve comfort feeling at start. Based on the brake condition, set 0.8-1.5s for synchronous machine, and 0.3-0.5s for asynchronous machine. |
| t4~t5 | Smooth start time (F2-13): Elevator runs in start smooth speed (F1-04) for a period at start up, this is to overcome part of the elevator static friction. This is normally set as 0.2s-0.4s, setting it too long may reduce the elevator start efficiency. |
| t6~t7 | Zero speed time (F2-0): When elevator runs to the destination floor and speed is lower than the zero speed limit (F1-16), after zero speed time (F2-04), brake release output is disabled. If zero speed time is set too short, brake may close before elevator completely stop. Normally this value is set to 0.2s-0.4s. |
| t7~t8 | Braking time (F2-01): After brake close, due to the subsequent flow and demagnetization, brake cannot lock on the traction sheave immediately and torque output is kept in the mean time. After braking time, system drop internal direction command and torque output. This time can prevent the elevator slip due to braking lag. Based on the brake condition, set 0.8-1.5s for synchronous machine, and 0.3-0.5s for asynchronous machine. |
| t8~t9 | After system drop internal direction command, stop output current immediately may generate large current noise. Time delay (F2-10) can be set to decrease output current gradually, finally stop the elevator after dropping the internal direction command. |
| t9~t10 | Time delay for running contactor open is 0.4s to prevent electric arc when contactor opens with current. But braking, emergency stop, door lock protection do not have time delay, they act immediately. |

6.3.2. Timing Diagram for Inspection Running

Timing diagram for elevator inspection running can be seen below in Figure 6.4

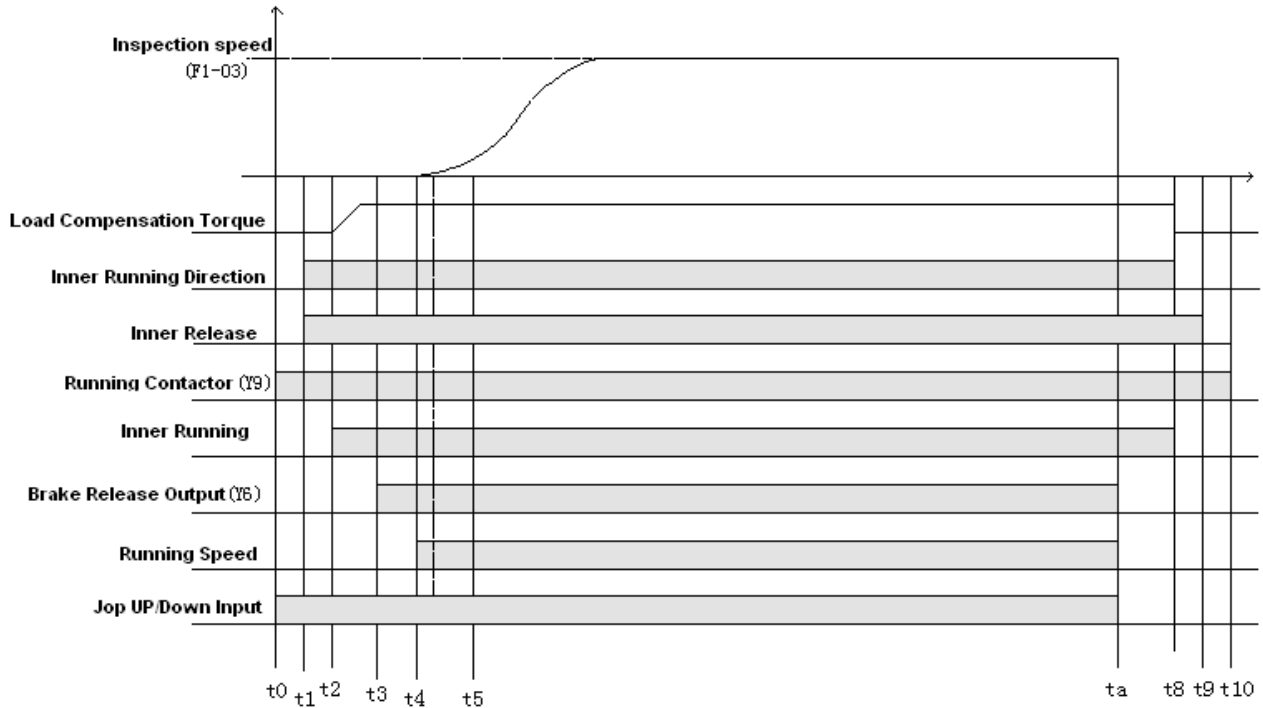

Figure 6.4 Timing Diagram for Elevator Inspection Running

Definitions and instructions for timing diagram above are shown below in table 6.2

Table 6.2 Timing Definition for Elevator Inspection Running

| Time | Definition and Setup Instruction |
|-------|---|
| t0~t9 | Definition for t0~t9 are the same with elevator normal running |
| ta~t8 | Inspection braking time (F2-02): At inspection running stop, system will not wait for elevator zero speed to close brake. When jogging up/down instruction is dropped, brake will close at once (with speed). For some asynchronous traction machines, holding time for torque output too long will result system trigger over-current protection. In this case decreasing the braking time can eliminate such protection. For synchronous machine control, this value should be same under normal running and set as 0.8s-1.5s, for asynchronous machine control, this value should be set as 0.1s-0.3s. |

6.3.3. Timing Diagrams for Rescue Running

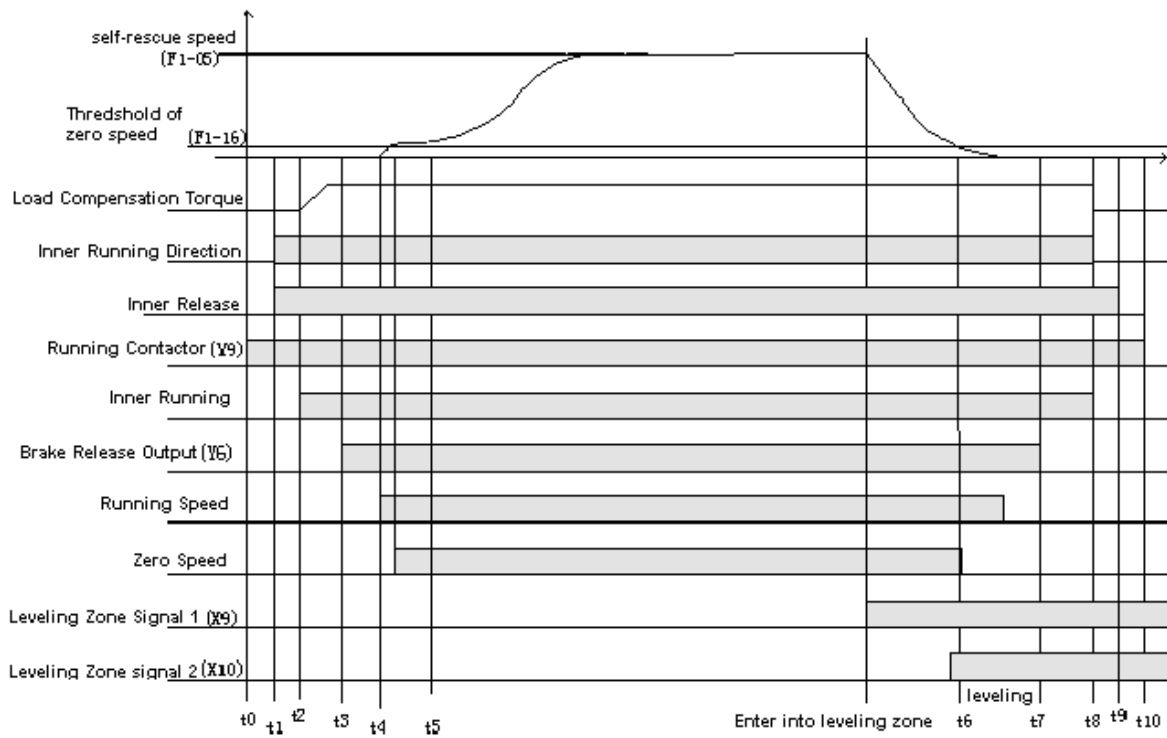

Figure 6.5 Timing Diagrams for Rescue Running (Same definition & setting with Normal Running)

6.3.4. Timing Diagram for Recalibration Running

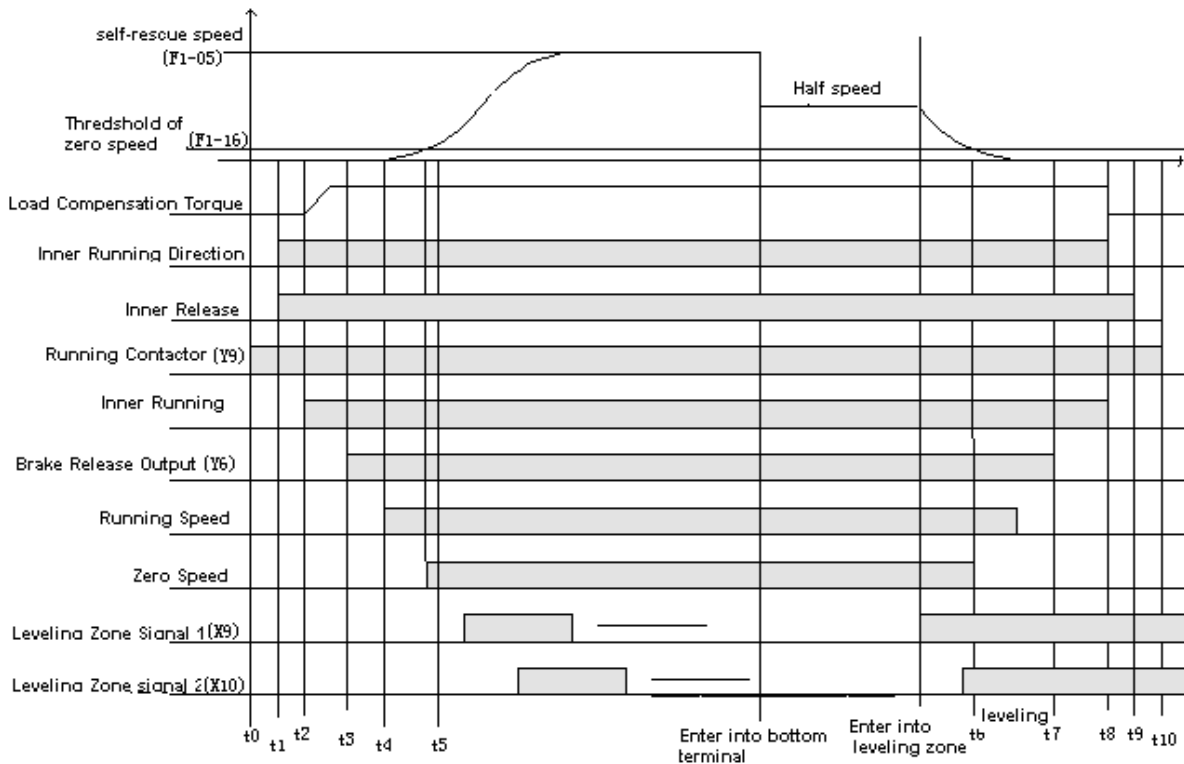

Figure 6.6 Timing Diagrams for Recalibration Running (Same definition & setting with Normal Running)

6.4. Door Control

6.4.1. Door Open/Close Control

For door control, door open and close time is the related parameter; door limit is the related signal. Timing diagram for door open and close can be seen below in Figure 6.7 and Figure 6.8.

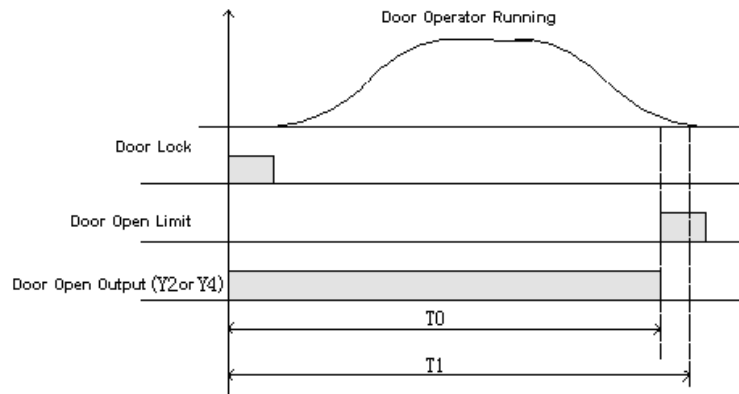

Figure 6.7 Timing Diagram for Door Open

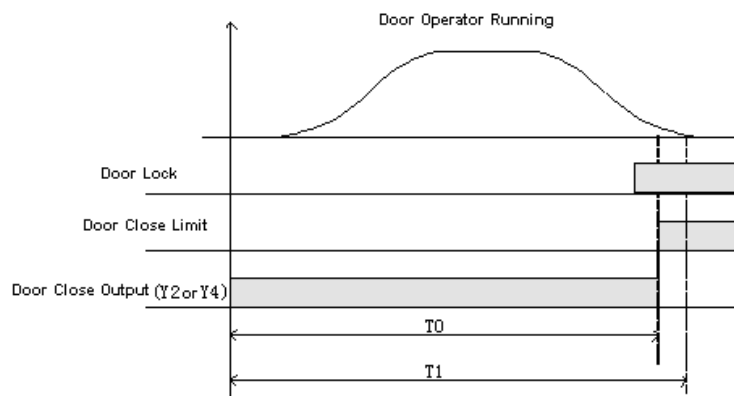

Figure 6.8 Timing Diagram for Door Close

T0: The actual door-drive running time for door to open or close completely;

T1: Door open or close time (F2-08).

T1 should be 1s more than T0 to ensure the door normal open/close action, otherwise:

1. After system output door close signal, but door does not close completely after T1 door close time (F2-08), elevator will open the door again, and door cannot be closed.

2. After system output door open signal, but door does not open completely after T1 door open time (F2-08), elevator stops the door open action, and door cannot reach the self-lock position.

Door close limit should be fixed in the position where it is only valid after door is completely closed, otherwise:

1. Door cannot close in inspection mode.

2. Door close limit valid, system stops output door close signal, door cannot close, system open the door again.

3. Door close limit is valid, system will open door after set time in F2-08. Door can still be closed under the holding force of door drive, but system will show a door close error, and elevator can run normally.

If the door open/close limit switches cannot be valid after installation, elevator will control door open/close based on time set in F2-08. If door open/close limit signals are normal; the control of door open and close will be based on door open/close limit signals.

6.4.2. Door Open Holding Time

Elevator run in auto mode, after landing, door open, and door will hold for following time:

1. After landing, door open, if elevator has no landing/car call, waiting time is door open holding time (F2-05).
2. After landing, door open, if elevator has only landing call, waiting time is door open holding time (F2-05) minus 2s.
3. After landing, door open, if elevator has both landing/car calls, waiting time is twice of door open holding time (F2-05) minus 2s.
4. If door open delay time (F1-30) is valid (Set as 1), and after door open, door open delay button is pushed, waiting time will be door open delay time (F2-06). After the delay time or press door close button to close door in advance and then reopen door again, door open delay function will be cancelled, unless push door open delay button again after door is open.
5. When elevator enables disabled function, if there are disabled landing/car calls on current floor, waiting time will be door open delay time (F2-06).

6.4.3. Door Control in Attendant and Special use mode

In attendant/special use mode, door must be closed manually. If door driving mode (F1-21) is set to 1, door close will be jog mode, if set to 0, door will close completely after pushing door close button, no need to push the button continuously.

6.4.4. Door Control in Inspection, Fire mode

In inspection mode, door open and close are both jog mode based on international standard.

Door control in fire-mode:

1. In fire mode, if elevator is running, elevator will land to the nearest floor but does not open door, then elevator return to fireman floor.
2. In fire mode, if elevator stops at other floor, door will not open after fully closed, then elevator return to the fireman floor. If door is open, door will close at once, but before the door is completely closed, the door can be opened again by pushing the door open button.
3. If elevator is at the fireman floor, it will open door and hold.
4. In fire mode, except on fireman floor, on all other floors door can only be controlled in jog mode.

6.5. Homing Function Setup

Elevator in auto mode (no duplex/group control), if there are no landing/car calls in set time, elevator will return to homing floor.

1. Set homing floor (F0-01)
2. Set homing time (F2-07), this function is disabled if set homing time to 0.

6.6. Parking Function Setup

Normal elevator lock input:

1. Electric lock input (X20) invalid, elevator in auto mode, it will return to parking floor (F0-03) after finishing all car calls.
2. Electric lock input (X20) invalid, elevator in attendant/special use mode, as door cannot close automatically, after finishing all car calls, door must be closed manually, elevator will then return to parking floor.
3. Electric lock input (X20) invalid, elevator in inspection mode, it will be locked at once.

Automatic Start/Stop:

Electric lock input (X20) valid, set auto parking (F1-28) as 1, automatic start time (F2-14), automatic stop time (F2-15) to correspond value to enable this function.

Electric lock input (X20) invalid, elevator will enter parking state; cannot set auto start/stop function.

In elevator auto stop time and elevator need to run temporarily, turn the electric lock to invalid and restore to valid, elevator will run. After the running, operate the electric lock in same procedures, elevator will re-enter lock mode, until reach auto-start time, then it starts running again.

6.7. Fireman Operation Function Setup

Controller has three kinds of fireman operation mode; fireman mode (F1-23) can be set as “0, 1, and 2”:

0: Normal fireman mode: When fireman input is valid, elevator lands to the nearest floor but doesn't open door, then it returns to the fireman floor(F0-02), it opens door and stops, meanwhile it enters into the fireman mode, elevator can run in fireman standard.

1: Fire emergency stop mode: When fireman input is valid, elevator lands to the nearest floor but doesn't open door, then it return to the fireman floor (F0-02), it opens door and stops. Meanwhile elevator stops running, until fireman input is eliminated.

2: Fireman control mode:

It includes two steps, step 1 is fire emergency return, and step 2 is fireman operation. Only after elevator returns to the fireman floor could step 2 be operated.

1. Fireman input switch has two states (ON/OFF); it is connected to X12 on main control board. Fireman operation switch has three states (ON/START/OFF), ON is connected to fireman input (by-pass input) on COP, START is connected to the door close input in parallel (For fireman to close door, when fireman turns the key to the START position, point ON is still valid, after releasing switch will automatically return to ON.)

Step1: Fireman input X12 is valid, if elevator is running, it will cancel all car call and landing call and stop at the nearest floor, but doesn't open door and then return to the fireman floor; if elevator is under stop and door open state, elevator will close door at once and return to the fireman floor. After elevator returns to the fireman floor, it opens door and stop running.

Step 2: Elevator in fire mode, return to fireman floor then stop running; At this time fireman operation running can be activated by fireman operator switch, switch to ON/STAR, elevator will run under fireman operation (Only serve one car call, door open and close follow fireman operation function). After switch to ON/STAR and elevator finished serving fireman operation, if elevator already leave the fireman floor, and switch is turned to OFF, at this time elevator will keep running. Only when elevator returns to the fireman floor again then it will stop running.

2. After elevator enters fire mode, light curtain input will be invalid. Elevator will exit from fire mode only when fireman input switch, fireman operation switch are both in OFF state.

6.8. Rear Door Control Setup

6.8.1. Different Mode Selection

On the same floor, both front/rear doors can be opened; there are different modes (0-n) available based on customer requirements.

Parameters setup for rear door mode is F1-22.

n=0: single door mode.

n=1: Rear door mode 1, only one door acts at every floor.

- n=2:** Rear door mode 2, two doors can open on some floors, but they cannot open at the same time, if one door needs to be opened, the other door must be closed first. (Two sets of COPs are needed for both front and rear door.)
- n=3:** Rear door mode 3, two doors can open at some floors, after landing on these floors, two doors open at the same time. (Only one set of COP is needed, HOP calling address is same for both doors.)
- n=4:** Rear door mode 4, two doors can open at some floors, after landing on these floors, two doors open at the same time. (Two sets of COPs are needed for both front and rear door.)
- n=5:** Rear door mode 5, two doors can act at some floors, when elevator runs to such floors, door will open as per requirement, for example: front/rear door will open on front/back car call and landing call. Both doors will open on both sides car/landing call. (Two sets of COPs are needed for both front and rear door.)
- According to the rear door mode, HOP address setting and COP wiring are different too:

HOP address setting

- 1) When rear door mode on controller is set as **0, 1, 3**, HOP address is same as usual;
- 2) When rear door mode on controller is set as **2, 4, 5**, HOP address is set as below:
 - a. **1~32** is the absolute floor number at front door side:
 - 1** is the bottom floor, **2** is second to bottom floor, maximum number is **32**, total **32** floors.
 - b. **33~64** is absolute floor number at rear door side:
 - 33** is the bottom floor, **34** is second to bottom floor, maximum number is **64**, total **32** floors.
 - c. If there is only one door on some floors, then the HOP address for the other door is empty.

Example 1: Elevator has one basement floor with both front and rear doors, on this floor HOP address is 1 for front door and 33 for rear door.

Example 2: Elevator has one basement floor with only front door, and one ground floor with both front and rear doors, on the basement floor HOP address is 1 for front door and empty for rear door. On the ground floor HOP address is 2 for front door and 34 for rear door.

C.O.P button wiring:

- 1) When rear door mode on controller is set as **0, 1**, **1~N** floor buttons are connected to the COP terminal as usual.
- 2) When rear door mode on controller is set as **2, 4, 5**: set total floor no. **N**, then the **1~N** car call ports correspond to **1~N** floor car call buttons at front door, **1** is the bottom floor, **N** is the top floor. **N+1~2N** floor car call ports correspond to the **1~N** floor car call buttons at rear door, **N+1** is the bottom floor, **2N** is the top floor.

For example: Elevator has 6 floors (1~6), no basement, 3rd floor has double entrance; other floors have only front entrance. Then car call buttons **1~6** at front door should be connected to **1~6** car call ports, car call button **3** at rear door should be connected to **N+3=6+3=9** car call port.



When rear door mode is **1, 2, 3, 4, 5**, need to install two sets of door open/close buttons, this is to open front and rear door separately in inspection running.



If rear door mode is 1, and there is one set of door open/close buttons, please set parameter FU18 to "ON". In other mode, if there is only one set of door open and close buttons, in inspection running, only front door can be opened by door open button, rear door cannot be opened by the button.

6.8.2. Rear Door Condition Setup

Front door setting parameter (F4-04) and rear door setting parameter (F4-05) are required to set front or rear door open on certain floors. In single door mode, these two parameters are invalid. In rear door mode, if set F4-04 to “ON” for some floors, front door can open on these floors, if set F4-04 to “OFF”, front door cannot open on these floors. This is same for rear door setup. Please set both doors condition based on actual situation to avoid door open mistake.

6.9. Input Type Setup

Input type on main control board (F3-00) and COP board (F3-01) can be changed based on actual ON/OFF state. When switch is at valid position/state and switch is closed, then its input type is ON. When switch is at valid position/state and switch is open, then its input type is OFF. Input type setup on main control board and COP board can be seen below in table 6.3

Table 6.3 Input Type Setup

| Name | Port | Position | Definition | Parameters | Default Input Level | Output Switch Default State | Indicator Default State |
|--------------------------|------|----------|--------------------------------------|------------|---------------------|-----------------------------|-------------------------|
| Main Control Board | X0 | J3-8 | Inspection Input | F3-00-00 | ON | OPEN | OFF |
| | X1 | J3-7 | Run up Input | F3-00-01 | ON | OPEN | OFF |
| | X2 | J3-6 | Run Down Input | F3-00-02 | ON | OPEN | OFF |
| | X3 | J3-5 | Top Terminal 2 Input | F3-00-03 | OFF | CLOSE | ON |
| | X4 | J3-4 | Bottom Terminal 2 Input | F3-00-04 | OFF | CLOSE | ON |
| | X5 | J3-3 | ▲Top Limit Input | F3-00-05 | ON | CLOSE | ON |
| Main Control Board F3-00 | X6 | J3-2 | ▲Bottom Limit Input | F3-00-06 | ON | CLOSE | ON |
| | X7 | J3-1 | Top Terminal 1 Input | F3-00-07 | OFF | CLOSE | ON |
| | X8 | J2-8 | Bottom Terminal 1 Input | F3-00-08 | OFF | CLOSE | ON |
| | X9 | J2-7 | Up Leveling Input | F3-00-09 | ON | OPEN | OFF |
| | X10 | J2-6 | Down Leveling Input | F3-00-10 | ON | OPEN | OFF |
| | X11 | J2-5 | Motor internal SC contactor feedback | F3-00-11 | ON | OPEN | OFF |
| | X12 | J2-4 | Fire Input | F3-00-12 | ON | OPEN | OFF |
| | X13 | J2-3 | Emergency Stop Input | F3-00-13 | ON | OPEN | OFF |
| | X14 | J2-2 | Door Interlock Input | F3-00-14 | ON | OPEN | OFF |
| | X15 | J2-1 | Brake Feedback/Main Contactor Input | F3-00-15 | ON | OPEN | OFF |
| | X16 | J1-10 | Assist contactor feedback Input | F3-00-16 | ON | OPEN | OFF |
| | X17 | J1-9 | Brake Contactor Feedback Input | F3-00-17 | ON | OPEN | OFF |
| | X18 | J1-8 | ARD function Input | F3-00-18 | ON | OPEN | OFF |
| | X19 | J1-7 | Spare | F3-00-19 | ON | OPEN | OFF |
| | X20 | J1-6 | Electric Lock Input | F3-00-20 | ON | OPEN | OFF |
| | X21 | J1-5 | Thermal Switch Input | F3-00-21 | OFF | OPEN | OFF |
| | X22 | J1-4 | Re-leveling condition Input | F3-00-22 | ON | OPEN | OFF |
| | X23 | J1-3 | Re-leveling sensor Signal Input | F3-00-23 | ON | OPEN | OFF |
| | X24 | J1-2 | Spare | F3-00-24 | ON | OPEN | OFF |
| | X25 | J1-1 | Spare | F3-00-25 | ON | OPEN | OFF |

Table 6.3 Input Type Setup (Cont'd)

| Name | Port | Position | Definition | Parameters | Default Input Level | Output Switch Default State | Indicator Default State |
|-----------------------------|---------|----------------|--------------------------|------------|---------------------|-----------------------------|-------------------------|
| Main Control Board F3-00 | X29+ | J6-3 | Emergency Stop Input + | F3-00-29 | ON | OPEN | OFF |
| | X29- | J6-4 | Emergency Stop Input - | | | | |
| | X30+ | J6-5 | Door Interlock Input + | F3-00-30 | ON | OPEN | OFF |
| | X30- | J6-6 | Door Interlock Input - | | | | |
| | X31+ | J6-7 | Spare + | F3-00-31 | ON | OPEN | OFF |
| | X31- | J6-8 | Spare - | | | | |
| Car Control Board F3-01 | KMV1 | J9-2 | Door open limit 1 Input | F3-01-07 | OFF | CLOSE | |
| | GMV1 | J9-3 | Door close limit 1 Input | F3-01-06 | OFF | CLOSE | |
| | KMV2 | J10-5 | Door open limit 2 Input | F3-01-05 | OFF | CLOSE | |
| | GMV2 | J10-6 | Door close limit 2 Input | F3-01-04 | OFF | CLOSE | |
| | KAB1 | J9-4 | Safety Plate 1 Input | F3-01-18 | OFF | CLOSE | |
| | KAB2 | J9-7 | Safety Plate 2 Input | F3-01-17 | OFF | CLOSE | |
| | CZ | J9-5 | Over load Input | F3-01-15 | ON | OPEN | |
| | MZ | J9-6 | Full load Input | F3-01-13 | ON | OPEN | |
| | QZ | J9-8 | Light load Input | F3-01-14 | ON | OPEN | |
| | KZ(50%) | J9-9 | 50% Load Input | N/A | | OPEN | |
| | SZH | J9-10 | Attendant Input | N/A | | OPEN | |
| | SZY | J10-1 | Special Use Input | N/A | | OPEN | |
| | SZS | J10-2 | Drive by-pass Input | N/A | | OPEN | |
| | ZHS | J10-3 | Attendant Up | N/A | | OPEN | |
| ZHX | J10-4 | Attendant Down | N/A | | OPEN | | |



If the top/bottom limit circuit is closed in normal state, default input level shows "ON".
If the top/bottom limit circuit is open in normal state, default input level shows "OFF".

6.10. Service Floor Setup

Non-stop floors in the system can be set through F4-00 and F4-01. For the floors elevator can land, set "ON", for the floors elevator cannot land, set "OFF". After setting F4-00, F4-01, elevator cannot land to the set floors in any case. Based on this function (refer to the function selection table), non-stop on certain floor in set time function is available too. Between the non-stop beginning time (F2-14/15) and ending time (F2-16/17), if elevator cannot land on some floors, please set the non-stop floors by setting F4-02 and F4-03 "OFF".

6.11. Weighing Device Setup

When using SJT-150 or SJT-300 weighing device, load detection is available through communication with main control board on CAN BUS. See below for setup procedures:

1. Enable weighing device F1-29=1, F9-11=1;
2. Perform light load and full load self-learning procedures;
3. According to the compensation condition, adjust the compensation coefficient F9-00.
4. For elevator with no compensation chain, adjust F1-18 based on actual condition on top and bottom floor:
 - a) Adjust the simulated load compensation gain in inverter until elevator runs down from top floor with no sliding;

- b) Move the empty elevator to bottom floor, increase load compensation adjustment parameter until elevator runs up from bottom floor with no sliding;
- c) The adjustment range for this parameter should be 0-12.

6.12. Duplex Control Setup

Controller has internal integrated duplex module, two elevators are connected through CAN1 in parallel, corresponded parameters need to be set to achieve duplex control.

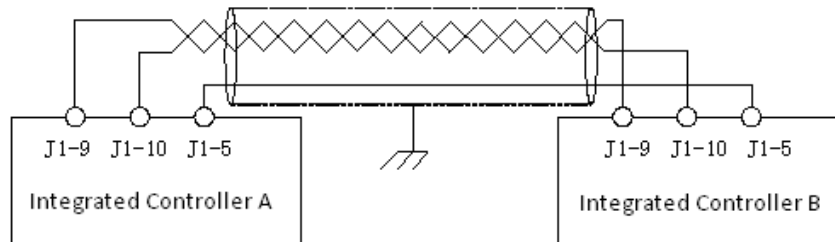

Figure 6.9 Connection for Duplex Control

Setup procedures:

1. Enable duplex control, F1-25=1
2. Set duplex elevator number F1-24, elevator A is set to 0, elevator B is set to 1.
3. Both elevators must have same fireman floor. (Otherwise call registers will be mixed up)
4. Call address should be set the same with single elevator.

After setup please save the parameters, reset the power and updating the communication address.

6.13. Group Control Setup

Main control board and group control board are connected through CAN1 port. (See group control board manual), corresponded parameters need to be set to achieve group control.

Setup procedures:

1. Enable group control, F1-26=1;
2. Set elevator number in F1-24, the number should be 0-7 for elevator A-H.
3. All elevators must have same fireman floor. (Otherwise call registers will be mixed up)
4. Call address should be set the same as single elevator.

After setup please save the parameters, reset the power and updating the communication address.

6.14. Leveling Adjustment Setup

After elevator landing, if elevator speed curve has no problem (i.e. there is no sudden stop and overrun leveling zone at elevator landing) and elevator runs outside leveling zone (it stops higher than leveling zone in up-running, lower than leveling zone in down-running), need to decrease leveling adjustment parameter F1-17 (default 50); if elevator cannot reach leveling position(it stops lower in up running, higher in down running), increase leveling adjustment parameter F1-17, general range for adjustment is 40-60, if the adjustment is big, please adjust driving parameter PI, or speed curve shape (F1-10~F1-15).

6.15. Floor Indication Setup

In parameter F0-05~F0-6, we can set third bit display, first two bit can be figure, characters or “-”, third bit can only be the following capital characters: ABCDEFGHIJKLMNOP. If only need two bits, set the first two bits only and third bit is empty. (Third bit indication should be supported by the HOP board, otherwise it cannot display normally.)

6.16. Special Function Selection

To meet certain special requirements from customers, this control system has included some customized functions (F4-06).

Table 6.4 Special Function List

| Number | Instruction |
|----------|---|
| F4-06-00 | After elevator stops, based on current floor, if there is no landing/car call ahead of the current floor in previous running direction, system will cancel all the car calls. |
| F4-06-06 | ON: For 7-segment display, Y25 is inspection mode output (must ensure the highest digit is not used). For other display mode, inspection mode output do not require to set Y25. |
| F4-06-07 | ON: At elevator running, direction arrow output with flash. |
| F4-06-08 | After setting 7-segment display output, when electric lock enabled, floor will still display (ON)/no display (OFF) |
| F4-06-09 | ON: Elevator can cancel registered car call at running. If all call canceled, elevator stop in nearby floor. |
| F4-06-10 | ON: Brake open when receiving inverter running feedback signal enable. OFF: Brake open 0.5s after receiving inverter running feedback signal enable. |
| F4-06-15 | ON: When setting 7-segment display mode, at electric lock enable or safety circuit open, turn off all display (all relays have no output). |
| F4-06-16 | ON: When door lock is closed, door close limit must be valid too. OFF: Door lock state is not related to door close limit. |
| F4-06-17 | ON: When elevator stops in inspection mode, inverter direction given and brake are released together. OFF: When elevator stops in inspection mode, inverter direction given drop is 0.5s later than brake close. |
| F4-06-18 | ON: In rear door mode, elevator only installs one set of door open& close buttons. OFF: In rear door mode, elevator installs two sets of door open & close buttons. |
| F4-06-21 | ON: In inspection mode, door cannot open outside levelling zone. OFF: In inspection mode, door can open at any position. |
| F4-06-22 | ON: Up/Down (single) collection OFF: Full selective collection |
| F4-06-23 | ON: Use SJT-300 weighing device through CAN BUS OFF: Use SJT-150 weighing device through RS485 |
| F4-06-25 | ON: When elevator cannot open door at current floor, it can automatically register the closest floor, approach and open door in that floor. |

6.17. Motor Parameters Setup

First, please set the motor parameters based on actual machine.

F5-00: motor type. 0: synchronous outer rotor machine; 1: asynchronous machine, 2: synchronous inner rotor machine.

Please make sure the machine type is set correctly, as system will perform motor auto-tuning and vector control based on motor type.

Also, please input following motor parameters based on the machine nameplate or user manual to ensure the accuracy of system generated motor digital model and vector control coupling.

1. F5-01: Motor poles
2. F5-02: Motor rated frequency
3. F5-03: Motor rated power
4. F5-04: Motor rated speed (RPM)
5. F5-05: Motor back-EMF (this parameter is only valid for asynchronous machine)
6. F5-06: Motor phase inductance (this parameter can be acquired from motor auto-tuning)
7. F5-07: Motor phase resistance (this parameter can be acquired from motor auto-tuning)
8. F5-08: Motor rated current
9. F5-09: No-load current (this parameter is only valid for asynchronous machine, it can be acquired from motor self-learning)
10. F5-10: Motor rated Slip (this parameter is only valid for asynchronous machine)

Beside above, when some parameters are not accurate, please perform motor parameter auto-tuning.

For the drive versions above 0007, parameter auto-tuning is not necessary.

6.18. Elevator Running Speed Setup

Elevator rated speed (F1-00) and motor rated speed (RPM) (F1-01) are used to calculate the ratio between elevator rated running speed and motor RPM. Also, with encoder pulse number per cycle (F1-03), we can get the relationship between each pulse and traveling distance in hoistway, and this achieves the distance detection of elevator running. Therefore changing F1-00, F1-01 will only change their ratio, but not elevator actual running speed.

When F1-03 for hoistway counting is from inner pulse source, pulse number in one cycle (F1-03) = pulse number of motor encoder (F8-00) / PG frequency division ratio (F8-01). Rated speed of traction machine (F1-01) = Motor rated speed (F5-04).

If F1-03 for hoistway counting is from outer pulse source (i.e. speed limiter encoder, must adopt special PG card), F1-03 should be set as pulse number in one cycle from outer pulse source, Rated speed of traction machine (F1-01) = Outer pulse source speed (i.e. speed limiter speed).

Speed given instruction can be seen below in figure 6.10.

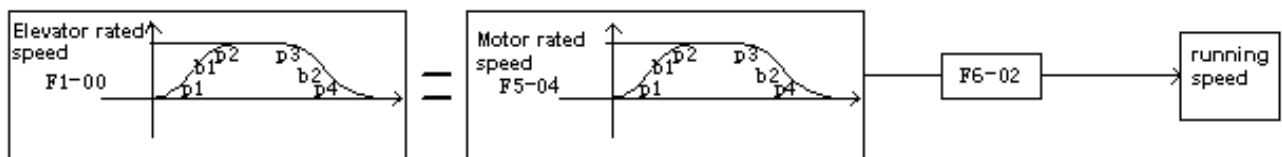

Figure 6.10 Speed Given Instruction

If need to reduce the elevator actual speed, please change the value of speed ratio (F6-02), when F6-02=100%, elevator runs in rated speed; reduce F6-02 elevator actual speed will decrease in corresponded ratio.

6.19. Speed Control Setup (PI Adjustment)

6.19.1. Speed Control Setup with Single PI Adjustment

For speed control under vector control, there are two ways, F7-00: when multi-section PI enable is set 0, PI does not change with speed given change. Instead, it is a fixed value for the whole elevator speed range, which simplifies setup procedures.

This is the most used method, the flow diagram can be seen below in figure 6.11.

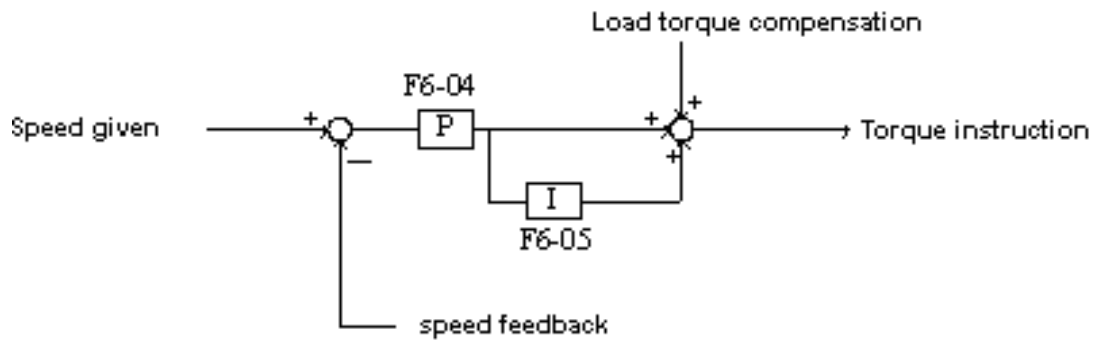

Figure 6.11 Speed Adjustments 1

6.19.2. Speed control Setup with Multi-Section PI Adjustment

For speed control under vector control, F7-00: multi-section PI enable is set 1, speed control function can be performed by PI changed in multi-section. In this control mechanism, parameters in F6-04 and F6-05 will not take effect all the time, instead, 4 groups of PI value F7-05~F7-12 are used to perform speed control.

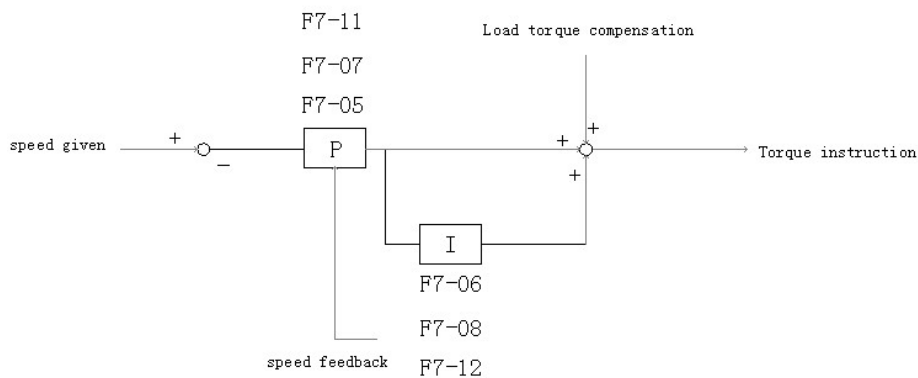

Figure 6.12 Speed Adjustments 2

F7-05, F7-06: Group 1 PI; it is generally adopted in low speed period at motor start.

F7-07, F7-08: Group 2 PI; it is generally adopted in middle speed section at acceleration period or steady-speed section at low speed period.

F7-11, F7-12: Group 4 PI; it is generally adopted in deceleration period.

Switching frequency for the above groups of PI parameter are set in F7-01~F7-04: frequency setting of PI effective range.

Group 1 PI effective range:

When motor starts from zero speed or in acceleration period, if the current frequency given is smaller than F7-01, system will adopt F7-05, F7-06 of group 1 PI to adjust the speed. To enable elevator quick stable at

zero speed when brake release and follow the speed curve quickly in initial acceleration, F7-05 and F7-06 can be set slight bigger.

Group 2 PI effective range:

After motor starts, when speed (acceleration) is larger than the set frequency in F7-01 and smaller than F7-02, system will adopts F7-07, F7-08 of group 2 PI to adjust the speed. When motor running speed is larger than the set frequency in F7-02, system will adopts F6-04 and F6-05.

Group 3 PI effective range:

When motor speed is smaller than the set frequency in F7-03 (deceleration), system will adopts F7-11, F7-12 of group 3 PI to adjust the speed. This group of PI parameters is used for adjustment in deceleration to stop period. If F7-03 is 0, system will adopt the last group of PI parameters before deceleration.

For different groups of PI effective range please see figure 6.13 below.

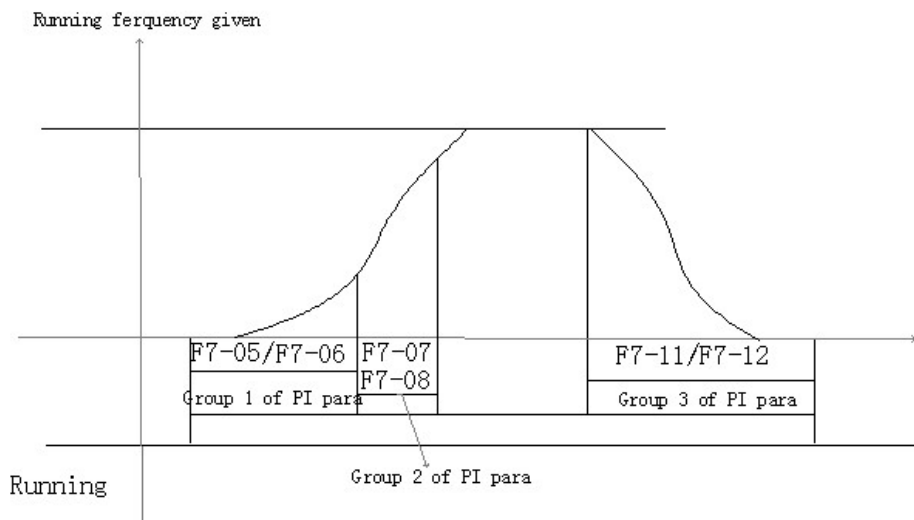

Figure 6.13 Effective range for different groups of PI

6.20. Load-Compensation Torque Output Setup

Parameters related to load compensation torque output control:

1. The parameters related when using of weighing device from Blue-light:
 - 1) F1-29: Weighing device enable (1: enable, 0: disable)
 - 2) U6-03: weighing value, the current load situation
 - 3) F1-18: weighing adjustment, adjust the compensation according to floor number, it is suitable for elevator without compensation chain.
2. Load simulative input, input range+10V~-10V or 0V~+10V, this input cannot be changed.
3. Load compensation source selection F9-13,
 - 0: Internal serial signal, it can only be used with Blue-light weighing device;
 - 1: External simulative input +10V~-10V;
 - 2: External simulative input 0V~+10V.
4. Maximum torque compensation F9-00; if set to 60%, the maximum output torque compensation at full load will be 60% of the rated torque.
5. Torque control output enable F9-11; if set to "1", system will output torque based on the source of F9-13 and multiply by F9-00; if set to "0", load compensation is disabled.

Output control diagram of load compensation torque can be seen below in figure 6.14.

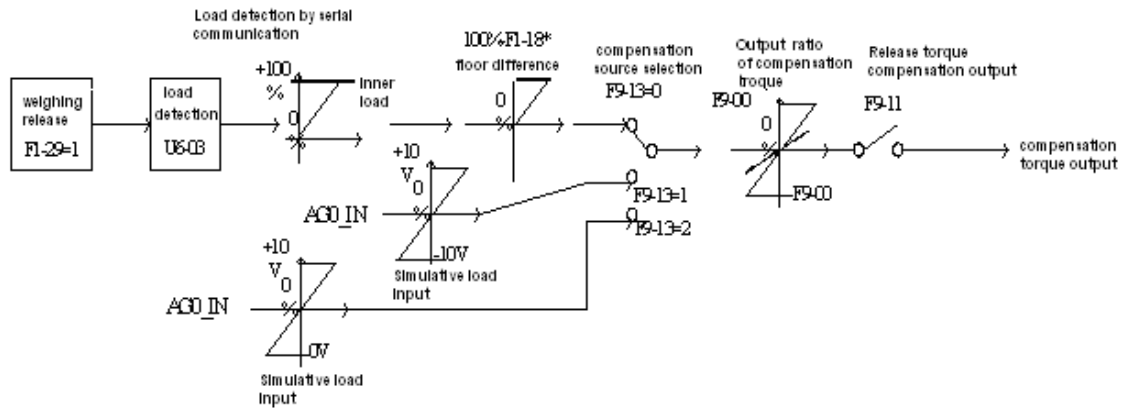

Figure 6.14 Load Compensation Torque Output Control

6. In synchronous machine control, as there is no compensation chain for low building, Blue -light weighing device can only measure the load in cabin and cannot detect the rope weight variation on different floor. In this case load compensation adjustment (F1-18) need to be used.

Adjustment Procedures:

- 1) Perform no-load, full-load learning;
- 2) Run the no-load elevator to top floor;
- 3) Adjust simulative load compensation gain in inverter until elevator does not slide when runs down from top floor.
- 4) Run the no-load elevator to bottom floor, increase the load compensation adjustment parameter (F1-18) until elevator does not slide when runs up from bottom floor.

6.21. Encoder Parameters Setup

Set F8-00 based on encoder pulse number. Encoder pulse usages can be seen below in Figure 6.15

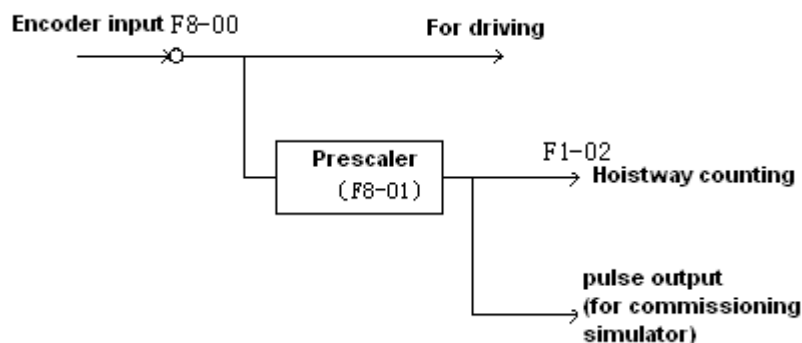

Figure 6.15 Encoder Pulse Usages

6.22. Start without Load Compensation Setup

When using BL3 series integrated controller with Sine/Cosine PG card, it is possible to achieve comfort start without load compensation by proper setup in FA group parameters. (It means elevator can reach the same effect of load compensation even without weighing device.)

1. Note for starting without load compensation:
 - 1) PG card type, F8-02 is set to "1" (Sine/Cosine PG card)

- 2) Weighing compensation invalid, confirms F9-11 is set to "0" to disable weighing compensation and enable FA group parameters.
 - 3) Drive software version, confirm version is 0005 or above.
2. Adjustment method for elevator starting without load compensation:
- 1) Principles: As can be seen in figure 6.16 below, when brake open, based on the position feedback from Sine/Cosine PG card, system can calculates the necessary torque required for motor to remain the steady position under current load, and it gives corresponded torque at once to minimize the traction sheave movement and to achieve comfortable start.

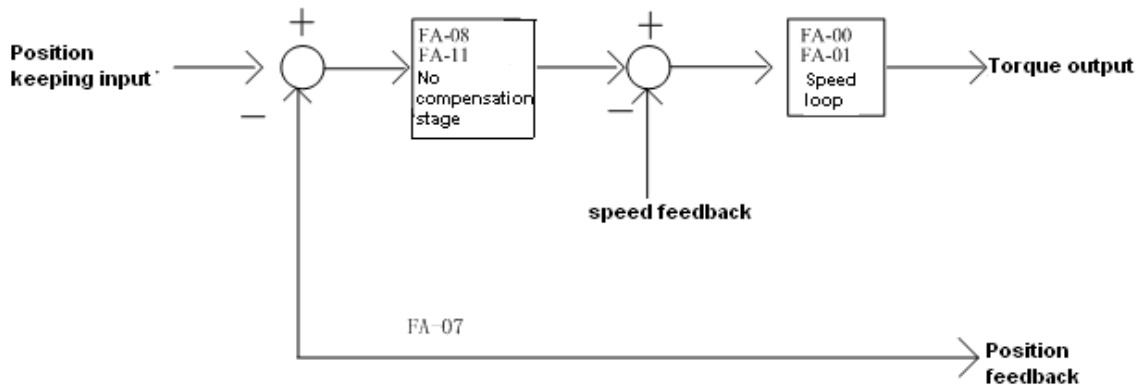

Figure 6.16: Flowchart for elevator starting without load compensation

- 2) Parameters: Parameters related to function can be seen below in table 6.5.

Table 6.5: Elevator start without load compensation parameters list

| Parameters No. | Display in Chinese | Factory Setting | Fast Brake Recommendation | Slow Brake Recommendation |
|----------------|--------------------|-----------------|---------------------------|---------------------------|
| | Display in English | | | |
| FA-00 | 启动段比例增益 | 30 | KEEP | KEEP |
| | StratKP | | | |
| FA-01 | 启动段积分增益 | 750 | KEEP | KEEP |
| | StratKI | | | |
| FA-08 | 无负载比例 1 | 3600 | 4800 | 3600 |
| | PLKP1 | | | |
| FA-09 | 无负载作用时间 | 900 | 700 | KEEP |
| | PLTime | | | |
| FA-11 | 无负载比例 1 | 800 | KEEP | KEEP |
| | PLKP2 | | | |
| FA-12 | 无负载比例系数 | 125 | KEEP | KEEP |
| | PLKPMOD | | | |
| F2-00 | 提前开闸时间 | 0.5 | 0.9 | 1 |
| | Brake ON Time | | | |
| F9-00 | 最大补偿力矩 | 0 | KEEP | KEEP |
| | Max Torq Comp | | | |
| F9-11 | 补偿使能 | 1 | 0 | 0 |
| | Load Comp Enable | | | |

3) Adjustment method: Main parameters used are FA-08, FA-09 and FA-11.

FA-09

This parameter is the working time for starting without load compensation after brake opens, it must be set according to the actual brake opening time, if the time is too short, elevator will slip as this action will be over before brake fully opened; Also the value of F2-00 (brake opening time before running) must be 100ms longer than the value of FA-09, so that this action can finish before speed curve start.

FA-08 and FA-11

Two gain parameters for the starting without load compensation action, these two parameters can be adjusted according to the elevator slipping condition and comfort level, if the slipping is too much please increase the value of FA-08; if the traction machine gets vibration, please reduce this value; during the period of torque keeping, if there is slight slipping or small back-and-forth movement on traction sheave, please increase the value of FA-11, if there is vibration, please reduce this value.



1. During commissioning, besides the mentioned 3 parameters, other FA group parameters can be kept with factory setting.



2. For different versions of program, the name of FA group parameters might be different, but their positions remain the same. As a result, only adjust FA-08, FA-09, FA-11 despite the operator version.



3. The setting value of above parameters is just for reference, as the PG card is not same in different job side; please adjust above parameters based on site condition.



4. F9-00 is the pre-set torque when the starting without load compensation function is enabled. Generally there is no need to change its value, please keep it with factory setting (0)

Chapter 7: Commissioning

7.1. Important Reminder

1. Thanks for purchasing our product, please read this manual and related instruction thoroughly before processing with installation, connection (wiring), operation, maintenance and inspection. To avoid any damage/loss of the products or accident to people, please make sure you have sound knowledge of the device and familiar with all safety information/precautions before processing to operate the control system.
2. Before commissioning and running the product, please read the manual carefully and refer to this manual during commissioning and running.
3. Make sure that all the mechanical devices are installed properly beforehand, especially the devices in hoistway (the devices that should be set in the machine room depends on the situation of the machine room).
4. Make sure that the installation and commissioning for the devices, which should be finished before commissioning of the control system, have been completed.
5. Before commissioning, it is necessary to get signature confirmation from the person who are responsible for mechanical installation and commissioning.
6. Make sure that all the mechanical devices and other devices which are related to the system commissioning are installed and tested properly.
7. Make sure that there are no unsafe factors which could cause injuries and damages to personnel and devices.
8. Commissioning should be carried out by qualified personnel.
9. Site should meet the conditions for commissioning and running.
10. When doing commissioning for both electric and mechanical parts, technicians for both parts should collaborate.
11. If this manual could not meet your requirement, please contact our company at once to acquire help and to avoid accident and loss.
12. Before system commissioning, make sure all the conditions are sufficiently prepared.

7.2. Inspections before Power On

After electric system is installed, please check the electric system carefully and pay attention to the following items:

1. Compare with the manual and electric diagram, check if the connections are all correct.
2. Check if there is interference between high voltage part and low voltage part. Use a multi-meter to measure the resistor in different circuit, resistor to earth must be infinity big.
3. Please check if wiring from power supply to the control cabinet and traction machine is correct, this is to avoid damaging the controller after powering on.
4. Check wiring between encoder and controller, coaxial degree of encoder and traction machine shaft, wiring between encoder and traction machine.
5. Check if the enclosure of the controller and motor, cabin, landing door are reliably earthed to ensure the safety to personnel.

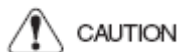

Controller enclosure and motor enclosure should be earthed to one point.

6. Make sure correct wiring of the terminal block **J1** on control board to avoid any damage to the main control board.

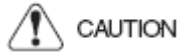

Controller has special digital operator, it should be connected to the socket J232 on main control board by a special cable before commissioning. USB serial communication cable is also available; connect it to the port USB0 on main control board to computer, then do commissioning with special software. (please refer to commissioning software manual)

7. Make elevator stop at the middle floor.
8. Turn electric lock to position "ON".

7.3. Power On and Inspection

7.3.1. Things need to confirm before Power On

1. Confirm all the air switches in control cabinet are open.
2. Confirm mode switch on the controller is at "inspection", emergency stop button is pressed.
3. Confirm inspection switches on car top and cabin are both in "normal" positions.
4. Confirm terminal resistor for bottom HOP is connected
5. Check voltage on the main power supply:: 3 phase voltage is $380\pm 15\%$ VAC, phase-phase voltage difference is smaller than 15VAC, phase-N voltage is $220\pm 7\%$ VAC.
6. Confirm the wire specification and main switch capacity match the design requirement.

7.3.2. Inspection after Power On

1. Close main power switch Q1, if phase relay KXX green LED on, it means the phase sequence is correct, otherwise red LED on, means phase sequence is incorrect, in this case please switch off the main power switch, exchange any two phase, and repeat the above inspection.
2. Inspect the terminal voltage on transformer **TC1**, the values should be in the range of $\pm 7\%$ of the indicated value, if voltage exceeds this range, find out the problem and correct it.
3. if the above inspections are normal, then do the following process:
 - a. Switch on F4: Voltage between terminal 100-101 should be $110\pm 7\%$ VAC
Voltage between terminal 103-102 should be $110\pm 7\%$ VDC
 - b. Switch on F5: Voltage between terminal 200-201 should be $220\pm 7\%$ VAC
 - c. **(Note: Connect digital operator before power on)** After power on, first see if the main menu display is correct on LCD indicator. For example: elevator state, fault state, door lock state, current floor, running speed and else. In this way we can tell if the controller is working properly and whether 24V power supply is normal. Interface on digital operator LCD screen can be seen below in figure 7.1

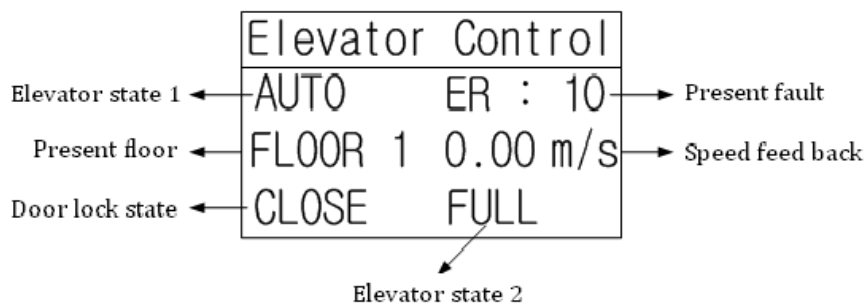

Figure 7.1 Digital Operator LCD Screen Interface

- d. Terminal voltage of switch power supply unit:

Table 7.1 Terminal Voltage for switch power supply unit

| Terminal | L ~ N | 24V ~ G |
|----------|-----------|-------------|
| Voltage | 220±7%VAC | 24.0±0.3VDC |

- e. After above inspections, do the following inspections:
- ◆ Check door lock circuit.
 - ◆ Check leveling zone signal, top/bottom limit signal.
 - ◆ Check electric lock, set the elevator auto-start/off time to “0”, set electric lock switch to “ON”, LCD screen will then display elevator state as “INSP”, if set electric lock switch to “OFF”, LCD screen will show “STOP”.
 - ◆ Check door open/close system, do corresponded adjustment if necessary.

7.4. Parameter Setup

It is very important to set Parameters based on actual site condition, as this is the foundation for controller or control system to maximize its performance. For parameter setups please refer to chapter 4-6. When setting parameters, please pay attention to the following points:

1. Set the motor basic parameters from motor nameplate namely motor parameter 1 content (F5 group). For example, motor type, pole numbers, rated frequency, rated power, rated RPM, rated current, Back-EMF (only for synchronous machine), no-load current (only for asynchronous machine), phase inductance, phase resistance and else. Amount which phase inductance, phase resistance and other parameters that are unknown can be acquired from motor -tuning; if system moment of inertia is unknown, leave it as default.
2. Set encoder parameter correctly (F8 group), for example encoder pulse, PG frequency division coefficient.
3. Set elevator running parameters correctly, such as motor rated RPM, encoder pulse (after frequency division.)
4. Set input type correctly, they should match the actual contactors, relays and hoistway contacts and switches.

7.5. Motor Parameters Tuning

Controller has motor parameter tuning function. Base on the input basic motor parameters, system automatically performs control, detecting, calculation, and recognize the unknown motor parameters required. For example, phase inductance, phase resistance, no-load current (only for asynchronous machine) and else.

Unless all the necessary motor parameters are known (F5 group), for example phase inductance (F5-06), phase resistance (F5-07) and all other parameters, please set the parameters directly and there is no need to run the motor parameter tuning. Otherwise motor parameter tuning is necessary.

7.5.1 Motor Rotation Tuning

Motor rotation tuning process is shown below:

1. Make motor (traction machine) with no load (do not attach the steel rope);
2. Short circuit running contactor output Y9 (J4-7) and COM3 (J4-6), make running contactor closed;
3. Short circuit brake output Y6(J4-10) and COM3 (J4-6), close braking contactor and release the brake;

On digital operator, perform the motor tuning command according to Figure 7.2

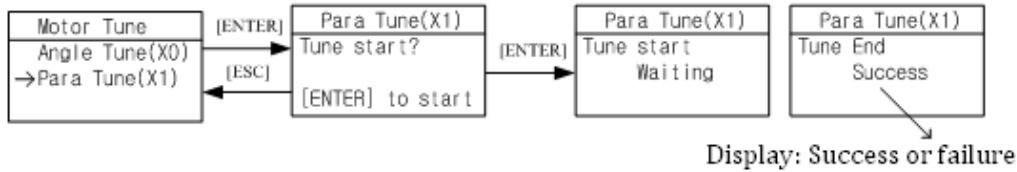

Figure 7.2 Motor Parameter tuning workflow

After press the “Enter” button, motor parameters tuning start. Motor will remain static after a short vibration, system continues to supply current and motor generates current noise. The whole process takes about 5 seconds.

If tuning success, return to parameter setting menu, check motor phase inductance (F5-06), and motor phase resistance (F5-07). They should all be adjusted to the correct value. Generally, one successful tuning is enough. However, if want to acquire more accurate results, one can record the results of this tuning, then repeat the process, and take the average value from tuning results.

If self-learning fails, operator will indicate the error code, please refer to the troubleshooting table in chapter 8, find out the reason and solve the problems, then start motor parameter tuning again.

7.5.2 Motor Static Tuning

Motor static tuning process is as follows.

1. Close brake.
2. Select tuning method parameter FX-20 to “1” on digital operator.
3. Short circuit running contactor output Y9 (J4-7) and COM3 (J4-6) to make it close; (If the system has a separate star short circuited contactor, close it as well).

On digital operator, perform the motor tuning according to Figure 7.2

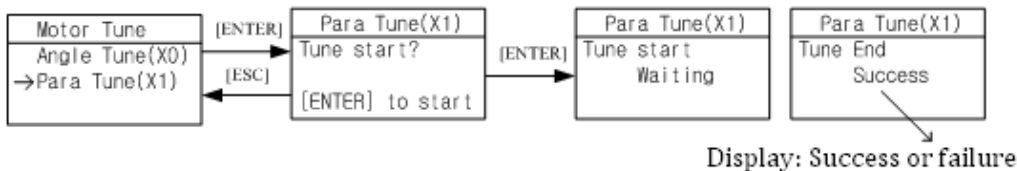

Figure 7.2 Motor Parameter Tuning Flowchart

If tuning success, return to parameter setting menu, check motor phase inductance (F5-06), and motor phase resistance (F5-07). They should all be adjusted to the correct value. Generally, one successful tuning is enough. However, if want to acquire more accurate results, one can record the results of this tuning, then repeat the process, and take the average value from tuning results.

If self-learning fails, operator will indicate the error code, please refer to the troubleshooting table in chapter 8, find out the reason and solve the problems, then start motor parameter tuning again.

7.6. Motor Initial Angle Tuning

For synchronous motor, besides the above parameter tuning, it is also necessary to perform motor initial angle tuning. Otherwise the machine cannot run normally, or even sever slip. Therefore, tuning initial angle is very important for synchronous machine. Before proceed to load run, synchronous machine must first perform initial angle tuning successful and no load running successful. For the tuning procedures, please refer to figure 7.3.

7.6.1. Tuning Procedures for Machine with Incremental Encoder

1. Synchronous motor (traction machine) must not have any load (don't hang on steel ropes);
2. Short circuit running contactor output Y 9 (J4-7) and COM3 (J4-6) to make it close;
3. Short circuit brake contactor output Y6 (J4-10) and COM3 (J4-6) to make it close and open brake;

On digital operator, tuning initial angle is as follows:

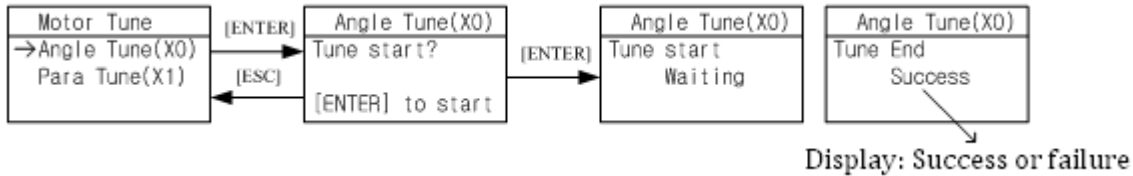

Figure 7.3 Motor Initial Angle Tuning flowchart

After pressing “Enter”, tuning starts. Motor vibrates at beginning or runs forward / reverse a little, then it accelerates forward to a certain speed (facing to traction sheave, anticlockwise rotation is forward direction), after 20s of constant speed running, motor stops; Then it accelerates forward to a certain speed, and after 20s running in constant speed, it stops again; Then it accelerates forward to a certain speed in third time, and after 20s running in constant speed, it stops and indicates “Success”. The whole tuning procedure lasts around 80s.

After tuning successful, perform a test run according to chapter 4 “4.4 Parameter commissioning in Digital Operator”. Make traction machine accelerate forward from zero speed to rated speed, run it in constant speed for a while and observe the running condition; make motor run in opposite direction in same way.

After test run with digital operator, please remove the short circuit on “running contactor output” and “brake control output”. Press jog up button on control cabinet to perform inspection running, observe motor running condition; Then press jog down button on control cabinet to perform inspection running, observe motor running condition.

When jog up (down), if the real running direction of cabin is down (up), please set F6-03 to correct it. 0: anticlockwise rotation is down, 1: anticlockwise rotation is up, set based on actual site condition.

After the above test running is finished, attach the steel rope and run motor with load.

For the site already had the steel rope, it can also perform the static initial angle tuning, the processing and notes can be seen in chapter 7.6.2.2.

7.6.2. Tuning Procedures for Motor with Sine/Cosine Encoder

For synchronous motor with Sine/Cosine Encoder, there are two methods for tuning initial angle.

7.6.2.1 Rotation Tuning

For this tuning method, make sure the motor has no load and brake is released.

Procedures required before tuning:

1. Ensure synchronous motor (traction machine) has no load (DO NOT attach steel ropes);
2. Short circuit running contactor output Y9 (J4-7) and COM3 (J4-6) to make it close;
3. Short circuit brake contactor output Y6 (J4-10) and COM3 (J4-6) to make it close and release the brake;

Set tuning method parameter FX-20 to “0” on digital operator (0: rotation tuning, 1: static tuning), after setting motor parameters (F5) and encoder parameters (F8) correctly, perform motor initial angle tuning based on the following procedures shown in Figure 7.3:

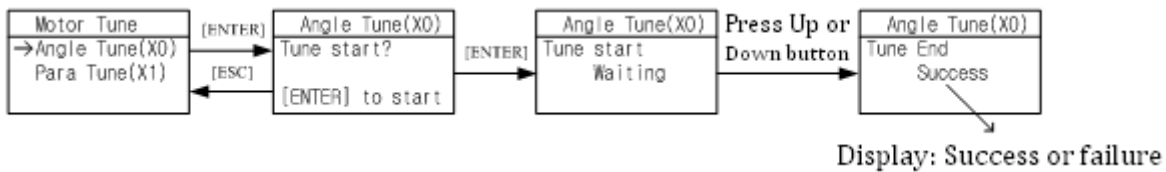

Figure 7.3 Motor Rotation Tuning on Initial Angle flowchart

After pressing “Enter”, tuning starts. First, motor rotates to a firm position, then it rotates forward (facing to driving shaft, anticlockwise rotation is forward direction) in a constant speed, rotation speed and time depends on the pole number and initial position, it stops after maximum one round rotation, then it rotates to one position and remains for 2 s again, motor stops and indicates success. The whole tuning procedure lasts less than 20s.

After tuning successful, perform a test run according to chapter 4 “4.4 Parameter commissioning in Digital Operator”. Make traction machine accelerate forward from zero speed to rated speed, run it in constant speed for a while and observe the running condition; make motor run in opposite direction in same way.

After test run with digital operator, please remove the short circuit on “running contactor output” and “brake control output”. Press jog up button on control cabinet to perform inspection running, observe motor running condition; Then press jog down button on control cabinet to perform inspection running, observe motor running condition.

When jog up (down), if the real running direction of cabin is down (up), please set F6-03 to correct it. 0: anticlockwise rotation is down, 1: anticlockwise rotation is up, set based on actual site condition.

After the above test running is finished, attach the steel rope and run motor with load.

7.6.2.2 Static Tuning

For this tuning method, tuning can be carried out with steel rope attached, but please make sure the following procedures are finished correctly before tuning:

1. Wiring in control cabinet is completely correct, and system under inspection state;
2. Running parameter (F1), motor parameter (F5) and encoder parameter (F8) are set correctly ;
3. All mechanical faults in hoistway have been eliminated; cabin and counterweight locate at center of the hoistway.

Set tuning method parameter FX-20 to “1” on digital operator (0: rotation tuning, 1: static tuning), perform motor initial angle tuning based on the following procedures shown in Figure 7.4:

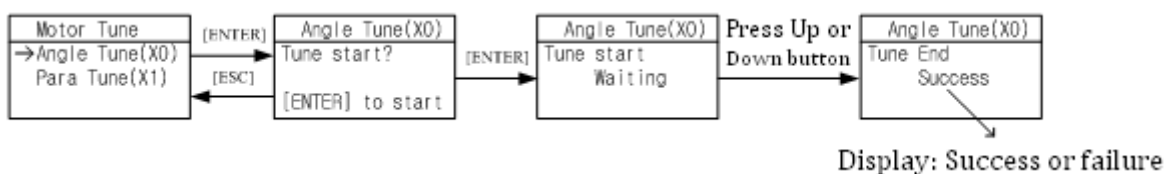

Figure 7.4 Motor Static Tuning on initial Angle flowchart

After pressing “Enter”, tuning starts. When digital operator indicates “running” , press jog up or down button , contactor KDY closes, motor will vibrate a little and give a noise, the duration depends on motor rated power and rated current, but no longer than 5s, this is static tuning period. (Make sure jog up or down button is pressed constantly, DO NOT release the button during this period.)Motor will then start and run in inspection speed , jog up or down, until digital operator indicates success, this is test running period. Finally, release the jog up or down button and finish the tuning procedure.

Please note the following items at motor static tuning:

1. To ensure safety, during tuning process, people is strictly forbidden to stay in car or hoistway;
2. Press up or down jogging button can base on the current cabin position;
3. The whole tuning procedures can be divided into two steps: static tuning and motor test run, make sure there is no gap between two steps. If no fault happens, before digital operator indicates success, press the jog up or down button constantly;
4. To achieve optimal control effect, it is recommended to repeat above tuning procedures 5 times, if the deflection of the results is small, take the average value.

If fault occurs in tuning, please refer to chapter 8 troubleshooting table, locate the fault and solve it accordingly, then repeat tuning procedures.

7.7. Inspection Running

7.7.1. Inspection Running in Machine Room

1. Things to check before inspection running in machine room.

- (1) Inspection switch in control cabinet is at “inspection” position, inspection switch on car top and cabin should be in “normal” position.
- (2) Safety circuit and door interlock circuit are normal, DO NOT short circuit door interlock.
- (3) After power on, **KJT** emergency stop contactor in control cabinet, **KMB** door interlock contactor, **KMC power** contactor are closed, check if the controller is normal and parameter setting is correct, in LCD indicator, elevator state is “**INSP**”.
- (4) Connect the brake to control cabinet properly.

2. Inspection running in machine room

When the conditions for inspection running in machine room are satisfied, press the Jog Up/Down button on the control cabinet, elevator will run up/down in set inspection speed.

For integrated controller with ARD function, the inspection switch is called "Emergency Run Mode Switch"

7.7.2. Inspection Running on Car Top/Cabin

If inspection running in machine room is normal, then can perform inspection running on car top and cabin. If the up or down direction of the buttons are opposite with the actual running direction, please inspect the jog buttons’ wiring, do not change the wiring in control cabinet.

7.8. Hoistway Learning

Hoistway parameter self-learning means elevator runs at a self-learning speed and measures every floor height and record the position of every switch in the hoistway. As the floor position is the foundation for elevator normal running, braking and floor display. Therefore, before normal running, hoistway parameter self-learning must be performed. Before hoistway parameter self-learning, inspection running in full trip must be performed too; elevator must be able to run normally from bottom limit to top limit.

Hoistway parameter self-learning procedure is as follows:

1. Make sure elevator meets the conditions for safety running;
2. Make sure all the switches in hoistway are installed and connected correctly, traveling cable and hoistway cable are connected correctly, and finish setting the HOP/display address;
3. Elevator in inspection mode, jog elevator down to the bottom limit (bottom limit is valid);
4. Enter elevator hoistway self-learning menu through digital operator, follow the learning procedures shown below in Figure 7.4

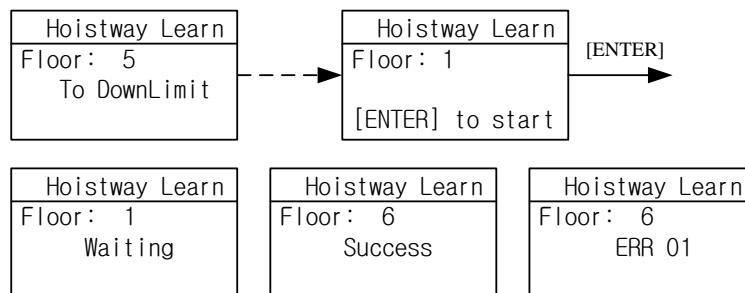

Figure 7.4 Hoistway Parameter Self-Learning Procedures

1. The results of learning can be seen from hoistway position parameter U00-U69 under monitor menu with unit of meter, please check the switches position after hoistway learning.
2. In self-learning process, if control system detects any abnormal phenomenon, self-learning will be terminated and give fault code, please refer to troubleshooting table in chapter 8, find out the reason and solve it accordingly, then start hoistway parameter self-learning again.



When self-learning process stops, only when LCD indicator shows “success” on digital operator, self-learning is completed successfully.

7.9. Normal Speed Running

After hoistway parameter self-learning is completed successfully, normal speed running can be carried out. Procedure as follows:

1. Switch elevator to attendant mode (Manual)
2. In floor selection parameter D0 through digital operator, target floor can be set (details refer to chapter 4.5 **Commissioning Parameters Setup**). Then it is possible to perform single floor traveling, double floor traveling, multi-floor traveling and full trip traveling test. Through D1 parameter interface, input door open and close instruction to control the door.

3. Make sure elevator can start, accelerate, decelerate and leveling normally in normal speed running.
4. If running is abnormal, please check for parameters setting.

7.10. Elevator Comfort Level Adjustment

If comfort level and leveling accuracy of elevator running are not perfect, please follow procedures blow. First, check the mechanical system condition (Such as clearance of guide shoes, lubricating, steel rope, position of the rope hitch plate and else.)which might influence the comfort of elevator running. After checking all the mechanical parts, then do adjustment in controller.

As the controller control the motor running according to the given starting/braking speed curve, therefore shape of the given speed curve, motor feedback speed to controller and the timing logic of controller signals directly influence the comfort level of elevator running.

7.10.1. Adjustment for Start/Brake speed curve

Elevator running speed curve is shown below in Figure 7.5.

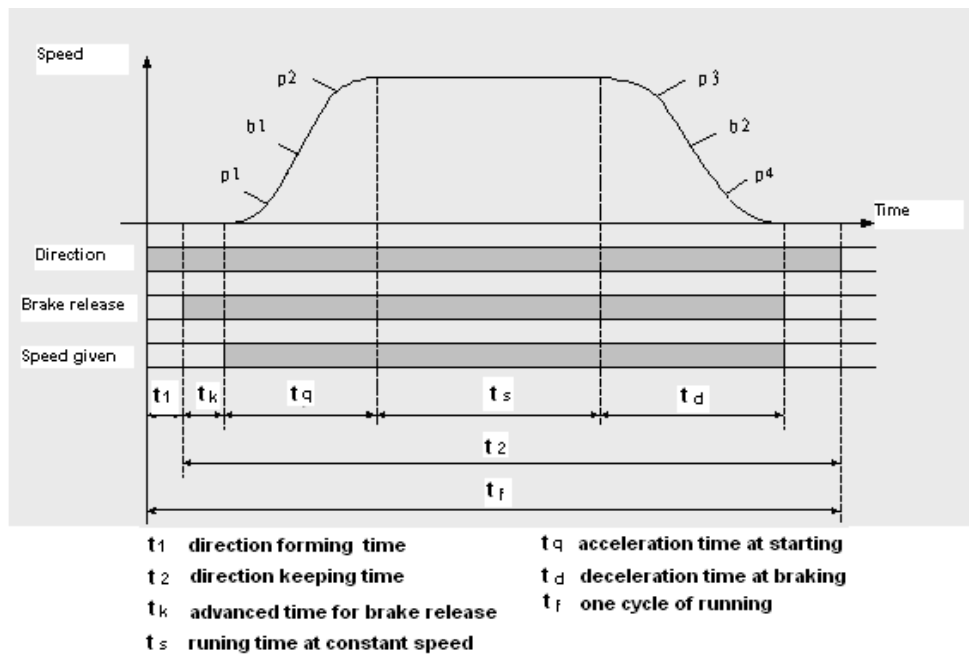

Figure 7.5 Elevator Running Speed Curve

1. Three parameters adjustment for motor starting S curve:

- 1) **P1:** Acceleration increase in starting section, it means the rate of elevator acceleration change. Smaller value means the slower starting section, the smoother running period and the lower the efficiency. On the other hand, faster at acceleration starting section means higher efficiency for elevator running.
- 2) **b1:** Acceleration in starting section, it means the rate of elevator speed change. Smaller value means the slower starting section, the smoother running period and the lower efficiency. On the other hand, faster at acceleration section means higher efficiency for elevator running.
- 3) **P2:** Acceleration decrease at end of starting section, it means the rate of elevator acceleration change. Smaller value means slower at end of starting section, the smoother running period and the lower efficiency. On the other hand, faster at acceleration ending section means higher efficiency for elevator running.

2. Three parameters adjustment for motor braking S curve:

- 1) **P3**: Deceleration increase at start of braking section, it means the rate of deceleration change, smaller value means slower at start of braking section is, smoother running period and lower efficiency. On the other hand, faster at brake starting section means higher efficiency for elevator running.
- 2) **b2**: Deceleration in braking section, it means the rate of elevator speed change. Smaller value means the slower braking section, the smoother running period and the lower efficiency. On the other hand, faster at braking section means higher efficiency for elevator running.
- 3) **P4**: Deceleration decrease at end of braking section, it means the rate of deceleration change. Smaller value means slower at end of braking section, smoother running period and the lower efficiency. On the other hand, faster at brake ending section means higher efficiency for elevator running.



Commissioning at jobsite need to first guarantee the elevator running efficiency, then adjust the above 6 parameters to achieve optimal elevator running curve.

7.10.2. Follow & Adjust Running Curve

To achieve the maximum level of comfort, integrated controller must control the motor and make feedback speed strictly following the change of running curve.

As the controller establishes the mathematic motor module based on the motor parameters input by the customers, and controller perform decoupling control by this module on motor starting/braking. Therefore, customer should input the motor parameters correctly. (When motor parameter is not precise or not confirmed, we suggest customer perform motor parameter tuning.)

Proportional gain on the speed circle **F6-04** and integral gain **F6-05 or F7-05~F7-12** for PI section parameters also influence the motor tracking ability to speed curve. Generally, increasing the proportion gain will improve the reaction of the system and promote the tracking speed. However, if proportion gain is set too big, it will cause system vibration with high frequency and large motor noise. Increasing integral gain can improve the system anti-interference/tracking ability and improve the leveling precision, but set integral gain too big will make system vibration, speed over adjustment and wave vibration.

Generally, it is recommended to first adjust the proportion gain, increase it right before system vibration threshold. Then adjust the integral gain, enable system with quick reaction and no over adjustment.

If system performance is not perfect at start or stop period (low speed period), try to control in multi-section PI, detail can be seen in 6.19.2 in section six.

7.10.3. Control Timing Adjustment

The control timing of this system can be seen in **Chapter 6.3**, , customer can adjust timing parameters and zero speed setting.

1. Timing adjustment: Refer to **Chapter 6.3** Timing diagram under different state
2. Zero speed setting: This parameter is the threshold of zero speed. Main control board determines braking time by this value. If this value is too big, elevator will stop with speed, if too small it will delay door open after elevator stop.

Generally, for asynchronous motor, it is 5 RPM, for synchronous motor, it is 1RPM.

7.11. Leveling Precision Adjustment

Leveling precision adjustment should be performed after comfort level adjustment is satisfied.

7.11.1. Basic Conditions for Elevator Leveling

1. Make sure the leveling switches and leveling inductor plates are installed in the right position.
2. Leveling inductor plates length on every floor must be same.
3. Leveling inductor plates must be installed vertically.
4. The position of leveling inductor plates should be precise. When elevator is at the leveling position, the center of the plate and center of two inductors should match together (refer to appendix), otherwise elevator leveling will have deflection, which means in up or down running, elevator stops higher or lower than leveling position.
5. If magnetic inductors are adopted, please make sure the inductor plates inserting to the inductor sufficiently, otherwise it will influence the reaction time of inductor, in that way elevator will overruns the leveling position.
6. To ensure precise leveling, system require elevator to crawl for a certain distance before stop.
7. In practice, first make adjustment for a middle floor, until leveling is precise. Then, adjust the other floors on the base of these parameters.

After adjusting curve selection, ratio and integral gain in the above context, please make sure every time elevator runs up or down, when stop at middle floor, its leveling positions are the same(or deflection $\leq \pm 2 \sim 3$ mm every time).

7.11.2. Leveling Parameter Adjustment

If elevator still cannot achieve desired leveling condition with adjustment based on instructions in chapter 7.9.1, further adjustments can be done by parameters. After elevator stops in normal running, if running speed curve has no problem (for example, no sudden stop or overrun beyond leveling zone), if elevator overruns the leveling position (it stops higher in up-running, lower in down-running), please decrease leveling adjustment parameter F1-17 (default: 50) . if elevator cannot reach the leveling position(it stops lower in up running, higher in down running), increase leveling adjustment parameter F1-17, generally the range of this parameter is 40~60, if the adjustment is too big, please adjust driving parameter PI, or the shape of speed curve (F1-10~F1-15).

7.12. Terminal Switch Position

Top and bottom terminal switch signal is used for elevator force deceleration and floor position calibration, it should be installed in the position where it is triggered when elevator is 2.5m ahead of top (bottom) leveling position (for **1.6m/s lift**). Testing method is as follows:

1. Switch elevator to inspection mode.
2. Set the inspection speed to 0.3m/s, jog run up (down).
3. Stop elevator when top (bottom) switch is triggered.
4. Distance between car sill and landing door sill should be 2.5 ± 0.1 m.

For the positions of terminal switches under other speed elevator, please refer to the appendix.

Chapter 8: Troubleshooting

This chapter explains in detail the fault display of integrated controller, the reasons behind and possible solution. The fault display on integrated controller may come from elevator system errors, Hoistway learning errors, driver errors, motor parameters setting and Encoder phasing errors.

8.1. Elevator System Faults

Table 8.1 Elevator System Fault List

| Error Code | Definition | Possible Solution |
|------------|---|---|
| Er2 | Door inter-lock faults: Door inter-lock circuit open at elevator running | Check the work condition of door vane and door interlock circuit. Roller should have enough space at both side of the vane. |
| Er3 | Driver faults | Based on error code, check details in table 8.3 |
| Er4 | Elevator running in opposite direction with command | 1. Exchange phase "V" and "W" on motor 2. Exchange phase "A" and "B", on encoder terminal block or change in parameter setup. |
| Er5 | System does not receive brake open feedback signal after output brake open command: 1. No X17/X15 feedback after Y6 output 0.5/2s. 2. X17/X15 enable when Y6 has no output. | 1. Check the traction machine brake detection switch and wiring; 2. If no feedback switch, should set feedback enable to OFF |
| Er6 | During elevator running, leveling zone input signal X9, X10 is always on. | Check leveling zone signal circuit and induction switch |
| Er7 | Inverter pulse not enough at elevator running. | Check the wiring from encoder to controller. |
| Er9 | Contactors KDY output not matching feedback signal: 1. After Y9 output X16 no feedback in 0.4s. 2. X16 is enable when Y9 has no output. | Check the contactor KDY coil and output/feedback circuit wiring. |
| Er10 | Safety circuit open, input X13, X29 is invalid. | Check all safety circuits. |
| Er11 | Leveling switch signal missing: Elevator is running pass the floor, but there is not input at X9 /X10. | Check the leveling switches and its wiring. |
| Er12 | Elevator pass top limit switch (X5 is invalid) | Check the encoder, top limit switch including its position and wiring. |
| Er13 | Elevator pass bottom limit switch (X6 is invalid) | Check the encoder, bottom limit switch including its position and wiring. |
| Er14 | Floor counter error from encoder deviation accumulation: after this error, elevator will return to bottom floor in inspection speed for recalibration. | 1. Check encoder wiring and related circuits; 2. Check the leveling switch and related circuits; 3. Possible reason: traction rope slip /door drive shake at start. |
| Er17 | No drive output after running command. | Check parameters in controller or contact supplier. |
| Er18 | Floor number error: after this error, elevator will return to bottom floor in inspection speed for recalibration. | Possible due to sudden power drop & elevator slip. Check the encoder and its wiring. |

Table 8.1 Elevator System Fault List (Cont'd)

| Error Code | Definition | Possible Solution |
|------------|--|---|
| Er19 | The deceleration distance for target floor is not enough, elevator did not perform hoistway parameter learning after changing terminal | <ol style="list-style-type: none"> 1. Decrease "Least Speed" in user menu; 2. Do hoistway parameter learning again. |
| Er20 | When elevator reaches top/bottom floor and get deceleration instruction, but elevator doesn't slow down; elevator did not perform hoistway | <ol style="list-style-type: none"> 1. Check the braking resistor specification 2. Increase controller PI gain parameters. 3. Make elevator running curve more smooth. |
| Er21 | Single running time is over set time | <ol style="list-style-type: none"> 1. Check the traction rope for slip or car jam. 2. Check related parameters in drive; 3. Check value of parameter "Over Time". |
| Er22 | Elevator has inspection signal input (X10 invalid) at elevator normal running. | Check inspection switch and related circuits. |
| Er23 | One of two leveling switch (X9, X10) is invalid at elevator normal running. | Check leveling switches and wirings. |
| Er25 | Heat sensor protection: Braking resistor or motor is over heat (X21 invalid). | Check heat sensor circuit. If this error cannot reset in 90s, Y10 relay on controller will output KMC contactor |
| Er26 | Door inter-Lock contactor working state does not match to its coil (X14, X30 input different) | Check door interlock contactor terminal & coil and their related terminal on controller. |
| Er27 | Emergency stop contactor working state does not match its coil state. (X13, X29 input different) | Check emergency stop contactor terminal & coil and their related terminal on controller. |
| Er28 | Top/bottom terminal (1st or 2nd) switch fault. (X7 or X8 valid when elevator outside their floor) | Check for terminal switches location and their wirings. |
| Er29 | Communication interference too much (In system or in duplex communication). | <ol style="list-style-type: none"> 1. Check system ground condition. 2. Check COP/LOP for possible damage that may influence CAN BUS communication. |
| Er30 | Door open fault (car cannot open door) | <ol style="list-style-type: none"> 1. Run elevator in inspection mode, give door open command and check Y4 for output signal. 2. If Y4 has no output, need to check door open, close limit switch and related signal. |
| Er31 | Door close fault (car cannot close door) | Normally due to door not installed properly and short circuit door interlock circuit. Check if door close and door interlock circuit are output at same time. |
| Er32 | Floor number counting error. | A sudden power break may affect terminal/limit switches and cause floor number error. Elevator will then return to bottom floor for recalibration. |
| Er33 | Motor star short circuited contactor fault | <p>KDY fault: KDY command not match feedback signal:</p> <ol style="list-style-type: none"> 1. Y8 output, X11 has no feedback in 0.4s 2. Y8 has not output, X11 is valid |

8.2. Hoistway Parameter Self-Learning Faults

Table 8.2 Hoistway Parameter Self-Learning Fault List

| Error Code | Definition | Possible Solution |
|------------|---|---|
| LER=0 | System running error | Press "ESC" to exit learning, check fault record shown in table 8.1 |
| LER=1 | Pulse input phase reverse | Exchange phase A and phase B in encoder. |
| LER=2 | Bottom terminal 1 switch input repeat. | Bottom terminal 1 switch installation error, causing multiple terminal switch input or bottom terminal 1 switch signal shake. Check related switches. |
| LER=3 | Bottom terminal 1 switch signal lost (elevator >2.0m/s) | Bottom terminal 2 switch enable before bottom terminal 1 switch or bottom terminal 1 switch signal lost. Check related switches. |
| LER=4 | Bottom terminal 2 switch signal repeat. (elevator >2.0m/s) | Bottom terminal 2 switch installation error, causing multiple terminal switch input or bottom terminal 2 switch signal shake. Check related switches. |
| LER=5 | Bottom terminal 2 switch signal lost (elevator >2.0m/s) | Top terminal 2 switch enable before bottom terminal 2 switch or bottom terminal 2 switch signal lost. |
| LER=6 | Top terminal 2 switch signal repeat. (elevator >2.0m/s) | Top terminal 2 switch installation error, causing multiple terminal switch input or top terminal 2 switch signal shake. Check related switches. |
| LER=8 | Top terminal 2 switch signal lost (elevator >2.0m/s) | Top terminal 1 switch enable before top terminal 2 switch or top terminal 2 switch signal lost. |
| LER=9 | Bottom terminal 1 switch signal lost | Top terminal 1 switch enable before bottom terminal 1 switch or bottom terminal 1 switch signal lost. |
| LER=10 | Top terminal 1 switch signal repeat | Top terminal 1 switch installation error, causing multiple terminal switch input or top terminal 1 switch signal shake. Check related switches. |
| LER=11 | Top terminal 1 switch signal lost | Top limit switch enable before top terminal 1 switch or top terminal 1 switch signal lost. |
| LER=12 | Total floor setting error | Check total floor number match actual floor number. Check leveling inductor plates on every floor. |
| LER=14 | Two leveling inductors cannot trigger together | Leveling inductor plate on this floor cannot cover both inductors or missing one leveling inductors. |
| LER=15 | Press "ESC" in the middle of hoistway parameter learning process. | Cancel the learning by pressing "ESC". |
| LER=17 | Up/Down leveling switch enable at same time | Wiring of two switches is parallel connection by mistake, or bottom limit switch is installed close to 1st floor leveling position. |
| LER=18 | Hoistway data saving error | ▲ Please contact supplier at once. |
| LER=19 | Both leveling switch signal enable together when arrive at top limit switch. | Move up top limit switch. |
| LER=20 | Bottom limit switch too high | Lower the bottom limit switch. |
| LER=21 | When elevator reaches top limit switch, bottom terminal 1/2 switch is valid. | Check the switches position and their wirings. |
| LER=22 | When elevator start from bottom limit switch, top terminal 1/2 switch is valid. | Check the switches position and their wirings. |

Note: System has 2 top and 2 bottom terminal switches for elevator speed >2.0m/s

8.3. Driver Faults

Table 8.3 Driver Fault List

| Error Code | Display | Definition | Possible Causes | Possible Solution |
|------------|---------|--|--|--|
| DF1 | UV | DC bus under voltage (for 400V drive, 380V at UV protection) | <ol style="list-style-type: none"> 1. Phase lost on input supply; 2. Instantaneous power lost; 3. Excessive input voltage fluctuation; 4. Loose terminals at input. | <ol style="list-style-type: none"> 1. Check input power supply; 2. Check input power cable terminals. |
| DF2 | OV | DC bus over voltage (for 400V drive, 760V at OV protection) | <ol style="list-style-type: none"> 1. Too short deceleration time, 2. Excessive motor regenerated energy; 3. Supply voltage too high 4. No connection to braking resistor. | <ol style="list-style-type: none"> 1. Increase deceleration time; 2. Connect brake resistor; 3. Check power supply. |
| DF3 | OH | Heat sink overheated | <ol style="list-style-type: none"> 1. Excessively ambient temperature; 2. Damaged cooling fan; 3. Existence of heat source around. | <ol style="list-style-type: none"> 1. Reduce ambient temperature; 2. Remove heat source around; 3. Check the fan and wiring. |
| DF4 | IF | IPM fault | <ol style="list-style-type: none"> 1. IPM over current/short circuit; 2. IPM over heat; 3. Abnormal IPM control power (UV) | <ol style="list-style-type: none"> 1. Check output short circuit; 2. Check motor short circuit; 3. Contact supplier. |
| DF5 | OC | Over current | <ol style="list-style-type: none"> 1. Inverter output short circuit; 2. Machine over-load; 3. Accel/decel time too short. | <ol style="list-style-type: none"> 1. Check motor short circuit; 2. Check accel/decel time, slow down if needed. |
| DF6 | CF | CUP faults | Too much interference. | Please contact supplier. |
| DF7 | OS | Elevator over speed. The speed feedback exceeds the speed limit and last longer than set time. | <ol style="list-style-type: none"> 1. Max speed /last time set incorrect; 2. Speed over-tuning; 3. Encoder feedback incorrect. | <ol style="list-style-type: none"> 1. Check speed limit setting; 2. Check the P/I parameter; 3. Check encoder |
| DF8 | OE | speed over deviation. The speed deviation exceeds the allowable range and last longer than set time. | <ol style="list-style-type: none"> 1. System overload; 2. Accel/decel time short; 3. Parameter setting wrong; 4. encoder cannot work properly. | <ol style="list-style-type: none"> 1. reduce system load; 2. Increase accel/decel time; 3. Check the parameters; 4. Check the encoder. |
| DF9 | PGO | PG disconnect, did not receive encoder signal at operation. | <ol style="list-style-type: none"> 1. Encoder wiring break, loose or wrong connection; 2. Encoder damaged. | <ol style="list-style-type: none"> 1. check encoder wiring; 2. Check encoder. |
| DF10 | FF | Flash memory fault | Data fault at saving parameters. | Please contact supplier. |
| DF11 | BF | Base block circuit error | <ol style="list-style-type: none"> 1. Wiring for base block at X14 is incorrect; 2. Setting electric level for base block at X14 is incorrect | <ol style="list-style-type: none"> 1. Check the wiring at X14; 2. Modify the parameters. |
| DF12 | OL | Motor overload, current output exceed 150% (200%) rated value for 60s (10s). | <ol style="list-style-type: none"> 1. System load too heavy; 2. System power rating too low. | <ol style="list-style-type: none"> 1. Reduce system load; 2. Change a more suitable controller. |
| DF13 | MC | Controller main contactor MC not close after given close command for set time. | <ol style="list-style-type: none"> 1. Wrong wiring for MC contactor; 2. MC contactor damaged. | Try to reset the power, if this error come again, contact supplier for replacement. |
| DF14 | BR | Brake unit fault | <ol style="list-style-type: none"> 1. defective brake cable or damaged brake elements; 2. External brake resistor disconnected or not connected. | <ol style="list-style-type: none"> 1. Check brake resistor; 2. Replace the controller. |

Table 8.3 Driver Fault List (Cont'd)

| Error Code | Display | Definition | Possible Causes | Possible Solution |
|------------|---------|--|---|---|
| DF15 | OF | Output phase lost | 1. Output cable break or loose terminal. 2. Motor stator cable disconnect. | 1. Check output cable/terminal; 2. Check motor stator cable. |
| DF16 | SCF | Output current remains at elevator stop. | Controller damaged. | Change the controller. |
| DF17 | SRF | Elevator slip after stop | 1. Brake/encoder loose; 2. Encoder interference. | 1. Fasten brake/encoder; 2. Remove interference source. |
| DF18 | UF | Signal U of encoder wire lost | Encoder damaged or wiring incorrect. | Check encoder and wirings |
| DF19 | VF | Signal V of encoder wire lost | Encoder damaged or wiring incorrect. | Check encoder and wirings |
| DF20 | WF | Signal W of encoder wire lost | Encoder damaged or wiring incorrect. | Check encoder and wirings |
| DF21 | DF | Parameter setting error | Parameter setting error | Check parameter setting |
| DF22 | SDF | Internal programmer self check error | Internal data setting error | Please contact supplier |

8.4. Motor Initial Angle Tuning Faults

For Incremental encoders

Table 8.4 Motor Initial Angle Rotation Tuning Fault List 1

| Error Code | Definition | Possible Causes | Possible Solution |
|------------|-----------------------------------|--|--|
| RF1 | Rotation tuning error | 1. Motor with load; 2. Motor phase is not correct; 3. Encoder damage or wiring incorrect. | 1. Make sure motor has no load; 2. Correct the phase of motor; 3. Check the encoder and wiring. |
| RF2 | Auto tuning data error | 1. Motor parameter setting error; 2. Encoder damaged or wiring incorrect; 3. High interference. | 1. Check motor parameter setting; 2. Check encoder and its wiring; 3. Reduce interference. |
| RF3 | Z-phase pulse lost at tuning | 1. Encoder damaged; 2. Encoder wiring is incorrect | 1. Check encoder; 2. Correct the wiring of encoder |
| RF4 | Auto tuning result is not correct | 1. Motor parameter setting incorrect; 2. Encoder and its wiring is incorrect; 3. Auto tuning motor with loads; 4. Speed circle P/I set too large. | 1. Check motor parameter setting; 2. Check encoder and its wiring; 3. Make sure motor has no load; 4. Reduce P/I parameter value. |
| RF5 | Auto tuning UVW repeated input | The encoder UVW wire have short circuit or disconnected | Check the encoder and wiring |

Table 8.4 Motor Initial Angle Rotation Tuning Fault List 1 (Cont'd)

| Error Code | Definition | Possible Causes | Possible Solution |
|------------|------------------------------|---|---|
| RF6 | Motor cannot rotate normally | 1. Motor with load; 2. Motor phase sequence is incorrect. | 1. Make sure motor has no load; 2. Check motor phase sequence. |
| Others | Check controller for fault. | If drive has fault, it cannot perform auto tuning, and it will give fault code. | Check the drive is fault or not |

For Sine/Cosine encoders

Table 8.5 Motor Initial Angle Rotation Tuning Fault List 2

| Error Code | Definition | Possible Causes | Possible Solution |
|------------|--------------------------------------|---|---|
| RF232 | Motor does not rotate at auto tuning | 1. Encoder connection fault; 2. Motor has load or brake close; 3. Motor parameter input error; 4. Motor & controller connection error. | 1. Check encoder signal connection; 2. Motor parameter input correct; 3. Check motor/controller connection; 4. Make sure motor has no load & brake open. |
| RF233 | Motor rotate in wrong direction | Motor phase sequences does not match encoder | 1. Adjust motor phase sequence 2. Adjust encoder A-, A+ or B-, B+ |
| RF234 | Encoder Z pulse signal error. | 1. No detection of Z pulse signal; 2. Motor/Controller connection error. | 1. Check wiring for Z pulse signal; 2. Make sure motor has no load. 3. Check motor/controller connection. |

Static Initial Angle Tuning Error

Table 8.7 Motor Initial Angle Static Tuning Fault List

| Error Code | Definition | Possible Causes | Possible Solution |
|------------|------------------------------|---|--|
| PF235 | Encoder Z pulse signal lost. | No encoder Z pulse signal detected after motor tuning for 7s. | If motor can running, check the encoder wiring; otherwise find out why motor cannot run. |
| PF236 | Internal counting error. | Internal counting error. | 1. Check the parameter input 2. Check motor/controller connection. |

Table 8.7 Motor Initial Angle Static Tuning Fault List (Cont'd)

| Error Code | Definition | Possible Causes | Possible Solution |
|-----------------|---|--|--|
| PF237 | Motor is not held still | Motor brake is not close or brake is too loose | Check motor brake. |
| | Tuning results error too large | After tuning 3 times, tuning results have large differences. | Check motor and encoder wiring ground condition. |
| PF238 | Detection current is too small | Motor/Controller connection is incorrect. | Check motor/controller connection. |
| PF239 | Tuning results have too large errors | After tuning 3 times, tuning results have large differences. | Check motor and encoder wiring ground condition, then try again. |
| PF240- PF249 | For incremental PG tuning, UVW signal error | The encoder UVW wires have wrong sequence or disconnection. | Check the UVW wiring with encoder |

8.5. Motor Parameters Tuning Faults

Motor parameters tuning error code and their possible causes and solution are shown below in table 8.6 and table 8.8. (Including rotation and static parameters tuning)

Motor Parameters Rotation Tuning Faults

Table 8.6 Motor Parameters Rotation Tuning Fault List

| Error Code | Definition | Possible Causes | Possible Solution |
|------------|---|--|---|
| PF2 | Motor parameter input incorrect or no input. | 1. Motor parameter input error; 2. Motor/Controller connection error. | 1. Check motor parameters; 2. Check motor/controller connection. |
| PF3 | Motor resistor tuning result error. | 1. Input motor data is incorrect; 2. Wire not secured on terminal block. | 1. Check input parameters; 2. Check the motor wiring and secured them on terminal block. |
| PF4 | Motor leakage inductance tuning result error | 1. Input motor data is incorrect; 2. Motor tuning with load. | 1. Check the input parameters; 2. Make sure motor has no load. |
| PF5 | Motor does not rotate in auto tuning. | 1. Motor parameter input incorrect; 2. Wire loose on terminal block; 3. PG card damaged or wiring incorrect. | 1. Check the input parameters; 2. Secure the wire on terminal block; 3. Check PG card and its wiring. |
| PF6 | Motor cannot reach rated speed or rotate direction error. | 1. Input motor data incorrect; 2. Motor input phase incorrect; 3. Encoder /PG card /wiring error. | 1. Check the input parameters; 2. Check motor input phase; 3. Check encoder, PG card and wiring |
| PF7 | No-Load Current error | Auto tuning motor with loads | Make sure the motor has no load. |

Motor Parameter Static Tuning Faults

Table 8.8 Motor Parameter Static Tuning Fault List

| Error Code | Definition | Possible Causes | Possible Solution |
|------------|---|---|---|
| PF2 | Initial fault | <ol style="list-style-type: none"> 1. Motor parameters input incorrect; 2. Motor/Controller connection error. | <ol style="list-style-type: none"> 1. Input correct motor parameters; 2. Check motor/controller connection. |
| PF3 | Motor resistor tuning result error. | <ol style="list-style-type: none"> 1. Input motor data is incorrect; 2. Wire not secured on terminal block. | <ol style="list-style-type: none"> 1. Check input parameters; 2. Check the motor wiring and secured them on terminal block. |
| PF4 | Motor leakage inductance tuning result error | <ol style="list-style-type: none"> 1. Input motor data is incorrect; 2. Motor/Controller connection error. | <ol style="list-style-type: none"> 1. Check input parameters; 2. Check motor/controller connection. |
| PF237 | Motor is not held still at initial tuning period. | Motor brake is not close or brake is too loose, causing sheave move during initial tuning period | Make sure motor brake is tightly closed. |
| PF238 | Current too small at initial tuning period. | Motor/Controller connection error. | Check motor/controller connection. |

Chapter 9: Maintenance

This chapter describes precautions and notes for drive storage and maintenance.

9.1. Safety Precautions for Drive Maintenance & Storage

Danger

- ◇ **There are high voltage terminals in integrated controller, please DO NOT TOUCH.**
Otherwise there has potential risk of electric shock.
- ◇ **Make sure to install front protection cover before power on integrated controller and cut power before removing the front protection cover.**
Otherwise there has potential risk of electric shock.
- ◇ **Before open case service/maintenance, make sure the power is cut for 10 minutes, power on LED (CL) is off and DC+/- bus voltage is lower than 24V.**
Otherwise there has potential risk of electric shock due to capacitor remain voltage.
- ◇ **Only authorized and qualified personnel are allowed to inspect/service integrated controller.**
Otherwise there has potential risk of electric shock and damage the product.
- ◇ **Before maintenance, technicians must remove any metal objects (watch, ring, ect), and must wear cloth with qualified isolation level.**
Otherwise there has potential risk of electric shock.
- ◇ **DO NOT remove or change terminal ports at controller power on.**
Otherwise there has potential risk of electric shock.
- ◇ **DO NOT change internal structure of the integrated controller.**
Otherwise there has potential risk of electric shock and damage the product.
- ◇ **After maintenance, please make sure all terminals and contactors are tightly secured.**
Otherwise there has potential risk of controller not functioning or even get damaged.

Attention

- ◇ **CMOS integrated circuits are applied in control board, please be aware.**
If touch by hand directly, the control board may get damaged due to static charge.

9.2. Daily Check

In order to increase the life time of controller and make sure the safety operation of elevator, it is necessary to check and inspect controller in a daily basis. As it is not allowed to remove the controller front cover with controller power on, the controller can checked by observing the device external condition, including:

1. Check if fan is working properly, including any abnormal noise.
2. Check if the LED indicator and digital operator of controller is working properly.
3. Check if there are any abnormal noise, vibration or smell.
4. Check thermal condition of controller and motor.
5. Check the ambient environment (Temperature $-10\sim 45^{\circ}\text{C}$, humidity $5\sim 95\%RH$, no frozen, no oil mist or powder in air)
6. Check if the comfort level of elevator has decreased dramatically.
7. Check if the input power and frequency are within rated range.

9.3. Routine Inspection

In order to increase the life time of controller and make sure the safety operation of elevator, it is necessary to check and inspect controller in a routine basis. At routine check, first switch elevator to inspection mode, stop elevator operation and cut system power. Then please perform inspections procedures based on table 9.1, following safety precautions and notes mentioned above.

Table 9.1 Routine Inspection Check List

| Check Item | Definition | Possible Solution for fault |
|-----------------------------|---|--|
| Terminal, connector, screws | Check for loose screws/bolts | Tighten the loose screws/bolts |
| | Check for loose connector | Reconnect the loose connector |
| Heat sink & Wind tunnel | Check for dust or any blockage. | Use dry air gun (0.4-0.6MPa) to clean dust, use proper tools to remove other attached objects. |
| PCBs | Check for dust, oil (conducting). | Use dry air gun (0.4-0.6MPa) to clean dust, use proper tools to remove other attached objects, replace PCB if necessary. |
| Cooling Fan | 1. Abnormal noise & vibration 2. Color/shape change due to heat 3. Loose bolts, screws. | For 1,2: Change fan For 3: Tighten screws. |
| Power device | Check for dust | Use dry air gun (0.4-0.6MPa) to clean dust or other objects. |
| Capacitor | Check for color, smell | Change controller or capacitor if necessary. |

9.4. Quick Wear parts

Controller is made from many components inside, all these parts have their lifetimes, and they depends on environment and working condition. As a result, in order to increase the life time of controller and make sure the safety operation of elevator, it is necessary to check and inspect some of these parts in a regular basis, replace them if needed. Table 9.2 below is the components change standard.

Table 9.2 Component change standard

| Item | Life time | Change method |
|------------------------|---------------------|--|
| Cooling Fan | 2-3 year (20000hrs) | Change new fan |
| Main circuit capacitor | 5 year | Change new capacitor (Decide after inspection) |
| Main circuit fuse | 10 year | Change new fuse |
| Capacitors on PCB | 5 year | Change new PCB (Decide after inspection) |
| Other components | ----- | Decide after inspection |

Note: Conditions below are required in order for components to reach life time mentioned above.

Ambient temperature: Average 30°C around one year

Load rate: Average below 80%

Running rate: Daily usage time <12 hrs.

9.5. Warranty

Integrated controller warranty period is 18 months after manufacturer (based on product name plate)

However, even within the 18-month warranty period, repair cost will be charged in the following cases:

1. Damage caused by miss-operation – not following manual guidance
2. Damage due to use outside rated range
3. Damage due to abnormal application of the drive
4. Damage due to natural environment, such as fire, flood, earthquake ect.

Chapter10: Controller installation with EMC Standard

This chapter explains in detail the integrated controller installation with EMC standard for reference.

10.1. EMC Briefing

EMC (short for Electromagnetic Compatibility) refers to the device/system capability to function normally in an environment with electromagnetic interference. It has two parts: first, the device/system must be able to work normally in environment with electromagnetic interference. Then, the electromagnetic interference it generated must be within a certain level so it will not affect other devices/systems in the environment.

10.2. EMC Characteristics of Integrated Controller

Same as other electronic devices, the integrated controller is affected by electromagnetic interference and at the same time it is also a source of electromagnetic interference. In order to enable the controller work normally in an electromagnetic environment, at the same time not to affect other devices, it is specially designed to deal with EMC characteristics shown below.

1. Input current is non-sine wave, with high frequency, this will cause strong electromagnetic interference.
2. Output voltage is high frequency PWM wave, this will cause strong electromagnetic interference.
3. As electromagnetic receiver, if controller receive too strong interference, it may not work properly.
4. Reduce controller generated electromagnetic interference will increase its own EMC level.

10.3. EMC Installation Guide

As determined by operating principle, the elevator integrated controller produces certain noises during operation. The effect of noise on peripheral equipment is relevant to the noise type, transmission path as well as the design, installation, wiring and grounding of drive system.

10.3.1. Noise Control

Basic strategy for noise control is to cut the transmission channel between noise source and noise receiver. Detail solutions are shown below:

1. Power cable and signal cable should be lay out separately and stay as far as possible, make sure to avoid two kind of cables stay in parallel or tied together. When meet situations in which signal cable must pass power cable, make sure two cables stay in perpendicular crossing and stay as far as possible.
2. All controller signal cable must have net shield, and the shield should be grounded at the controller side, with grounding area as large as possible.
3. For signal cables easy to get interference, such as encoder cable, it should have double twist shield cover, with grounding area as large as possible. One suggestion is to put the cable in metal tube or in a individual metal cable tunnel with reliable grounding condition.
4. Power cable and motor cable should use power cable with armor cover or shield. Power cable should use individual metal cable tunnel with reliable grounding point at controller side. Motor cable should follow the same grounding principle and its shield should also connect to motor cover at motor side.

5. Power cable should be connected to inverter use RFI filter or output reactor. Motor cable should be connected with output filter (sine/cosine filter) or install output reactor. Another solution is to surround motor cable twice with ferrite magnetic circle.
6. Other device that are easy to get interference should be put far away from the controller and power cable.
7. Inductive devices around controller such as contactor, relay, brake unit, their coil need to install surge controller (such as RC filter, resistor or freewheeling diode).

10.3.2. Wiring

1. Wiring in Control Cabinet

- 1) Inside control cabinet, signal cable and power cable should be placed in different area, with minimum distance of 20cm. DO NOT put two kinds of cables in parallel or tied together. If must cross two cable, they must remain strictly perpendicular with each other.
- 2) The input (power) and output (motor) of power cable cannot cross or tied together, especial when the cable is connected with input/output filter.
- 3) Inductive devices inside control cabinet (such as contactor, relay, brake unit), their coil need to install surge controller (such as RC filter, resistor or freewheeling diode).
- 4) Both signal and power cable should have net shield/armor with high frequency low impedance.
- 5) Cable shield should ground with large area.

2. Wiring at site

- 1) Power cable must have 5 wires, including U/V/W, one for ground and one for neutral, DO NOT mix use.
- 2) At site, signal cable and power cable should be placed in different area, with minimum distance of 20cm. DO NOT put two kinds of cables in parallel or tied together. If must cross two cable, they must remain strictly perpendicular with each other.
- 3) Signal cables must have net shield, the shield should be grounded at controller side with large ground area.
- 4) Power cable and motor cable should use power cable with armor cover or shield. Power cable should use individual metal cable tunnel with reliable grounding point at controller side. Motor cable should follow the same grounding principle and its shield should also connect to motor cover at motor side.

10.3.3. Ground Connection

Controller must be connected to the ground at work, grounding helps to solve the EMC issue, at the same time it brings safety to the device and people. Ground correctly is the most important (and most reliable/economic) solution to EMC issue, and it should be considered first. Notes for ground connections are shown below:

1. Control cabinet must have GND public terminal (copper plate).
2. The case of control cabinet must be connected to the ground public terminal. This connection can be made between cabin door and ground public terminal copper plate (width >15mm).
3. All ground connection must remain complete on both sides, cannot connect two grounding wire in the middle.
4. The ground of integrated controller must be connected to the ground public terminal.

5. Power cable, motor cable and brake resistor cable (if necessary) shield/armor must be connected to the ground public terminal.
6. The distance from cable shield to ground public terminal should be <50mm.
7. Ground connection wire should have low impedance (large cross sectional area and short in length).
8. Power cable should have 5 core (U,V,W, neutral & ground) with shield, motor cable should have 4 core (U, V, W, ground) with shield. For motor cable ground wire, one terminal should be grounded at controller side, another terminal should be grounded at motor side.

10.3.4. Leakage Current

Leakage current happens between wire and to ground, it depends on wire capacitance and controller carrier frequency. Leakage between wire is related to wire capacitance between controller input (power cable) and output (motor cable), controller carrier frequency, motor/power cable cross sectional area and length, while leakage current to ground is located at ground public terminal, it will get into the system and (in some case) affect other electrical devices through ground connection.

Countermeasure for leakage current:

1. Reduce controller carrier frequency;
2. Keep the power and motor cable as short as possible;
3. Power and motor cable cross sectional area should not be too big;
4. For long motor cable (>50m), controller output should have filter or reactor;
5. Should equip inverter use leakage current circuit break.

10.3.5. Power Line Filter

The power line filter is two-way low pass filter which only permits flowing of DC current or 50HZ operating frequency AC current but stops flowing of higher frequency electromagnetic interference current. Therefore, it can not only inhibit the equipment's electromagnetic interferences flowing into power line but also inhibit the noises in power line flowing into equipment.

Precautions for Installation of Power Line Filter:

1. In the cabinet, the filter should be located close to the power line inlet as practicably as possible. Additionally, the filter supply line section left in the control cabinet must be as short as possible.
2. The power line filter should be grounded with reliable connection, and the grounding area should be as large as possible.
3. The power line filter metal case should be securely attached to the control cabinet plate, with contacting area as large as possible and ensure good electrical connection.
4. Please use power line filter that matches the system, such as inverter use power line RFI filter.

10.4. EMC standard satisfied by Integrated Controller

When install integrated controller and EMI filter, if the installation procedures are following EMC installation guide, then the system could meet the standards below:

EN61000-6-4: EMC test in Industrial Environment 1800-3。

EN61800-3: EMC Standard (2nd Level Environment)

EN61000-6-3: EMC Standard (Residential Environment)

EN61000-6-4: EMC Standard (Industrial Environment)

Chapter 11: Accessories

11.1. Elevator Parallel Connection Extension Board (BL2000-EBA)

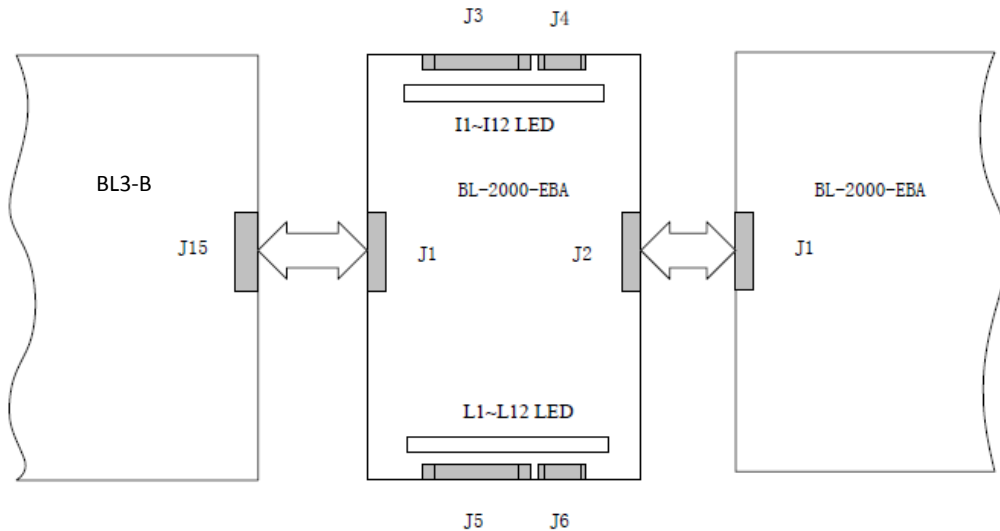

Figure 11.1 BL2000-EBA Interface Diagram

11.1.1. Function

BL2000-EBA is used to extend the input/output function of Parallel integrated controller BL3-B. J1 is used for extension input (to integrated controller), J2 is used for extension output (to next extension board); J3, J4 are used for input; I1-I12 LED is the display of I1-I12 input signal; J5, J6 are used for output; L1-L12 LED correspond to L1-L12 output signal (output relay) display.

11.1.2. Terminal Definition & Specification

Table 11.1 Terminal J3 input signal I1-I10 Definition (assume main board only have 5/6 floor output in full/single collective control)

| Terminal Number | Location | Definition (Input) | |
|-----------------|----------|---|---|
| | | VVVF | 2 Speed |
| I1 | J3-1 | Full/Single Collective: Car Call 6/7 | Full/Single Collective: Car Call 10/13 |
| I2 | J3-2 | Full/Single Collective: Car Call 7/8 | Full/Single Collective: Car Call 11/8 |
| I3 | J3-3 | Full/Single Collective: Car Call 8/9 | Full/Single Collective: Car Call 12/9 |
| I4 | J3-4 | Full/Single Collective: Car Call 9/10 | Full/Single Collective: Car call 13/10 |
| I5 | J3-5 | Full/Single Collective: up call 5/car call 11 | Full/Single Collective: up call 9/car call 11 |
| I6 | J3-6 | Full/Single Collective: up call 6/car call 12 | Full/Single Collective: up call 10/car call 12 |
| I7 | J3-7 | Full/Single Collective: up call 7/ car call 13 | Full/Single Collective: up call 11/car call 13 |
| I8 | J3-8 | Full/Single Collective: up call 8/ Hall call 8 | Full/Single Collective: up call 12/ hall call 8 |
| I9 | J3-9 | Full/Single Collective: down call 6/ Hall call 9 | Full/Single Collective: down call 10/ hall call 9 |
| I10 | J3-10 | Full/Single Collective: down call 7/ Hall call 10 | Full/Single Collective: down call 11/hall call 10 |

Table 11.2 Terminal J4 input signal I11-I12 Definition (assume main board only have 5/6 floor output in full/single collective control)

| Terminal Number | Location | Definition (Input) | |
|-----------------|----------|---|--|
| | | VVVF | 2 Speed |
| I11 | J4-1 | Full/Single Collective: down call 8/ hall call 11 | Full/Single Collective: down call 12/ hall call 11 |
| I12 | J4-2 | Full/Single Collective: down call 9/ hall call 12 | Full/Single Collective: down call 13/hall call 12 |
| | J4-3 | NOT USED | |
| | J4-4 | NOT USED | |
| | J4-5 | NOT USED | |

Table 11.3 Terminal J5 Output signal L1-L10 Definition (assume main board only have 5/6 floor output in full/single collective control)

| Terminal Number | Location | Definition (Output) | |
|-----------------|----------|---|---|
| | | VVVF | 2 Speed |
| L1 | J5-1 | Full/Single Collective: Car Call 6/7 | Full/Single Collective: Car Call 10/13 |
| L2 | J5-2 | Full/Single Collective: Car Call 7/8 | Full/Single Collective: Car Call 11/8 |
| L3 | J5-3 | Full/Single Collective: Car Call 8/9 | Full/Single Collective: Car Call 12/9 |
| L4 | J5-4 | Full/Single Collective: Car Call 9/10 | Full/Single Collective: Car call 13/10 |
| L5 | J5-5 | Full/Single Collective: up call 5/car call 11 | Full/Single Collective: up call 9/car call 11 |
| L6 | J5-6 | Full/Single Collective: up call 6/car call 12 | Full/Single Collective: up call 10/car call 12 |
| L7 | J5-7 | Full/Single Collective: up call 7/ car call 13 | Full/Single Collective: up call 11/car call 13 |
| L8 | J5-8 | Full/Single Collective: up call 8/ Hall call 8 | Full/Single Collective: up call 12/ hall call 8 |
| L9 | J5-9 | Full/Single Collective: down call 6/ Hall call 9 | Full/Single Collective: down call 10/ hall call 9 |
| L10 | J5-10 | Full/Single Collective: down call 7/ Hall call 10 | Full/Single Collective: down call 11/hall call 10 |

Table 11.2 Terminal J6 Output signal L11-L12 Definition (assume main board only have 5/6 floor output in full/single collective control)

| Terminal Number | Location | Definition (Output) | |
|-----------------|----------|---|--|
| | | VVVF | 2 Speed |
| L11 | J6-1 | Full/Single Collective: down call 8/ hall call 11 | Full/Single Collective: down call 12/ hall call 11 |
| L12 | J6-2 | Full/Single Collective: down call 9/ hall call 12 | Full/Single Collective: down call 13/hall call 12 |
| | J6-3 | COM public terminal | |
| | J6-4 | COM public terminal | |
| | J6-5 | COM public terminal | |

11.2. Elevator Group Control Board BL2000-QKB-V1

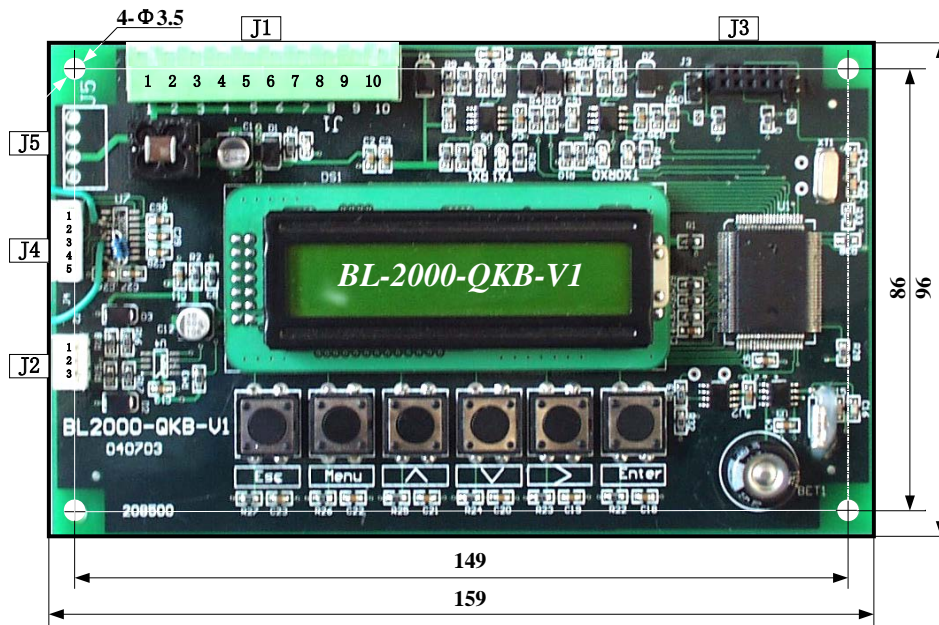

Figure 11.20 Group Control Board BL2000-QKB-V1 Shape & Dimension

11.2.1 Function

1. Group control system is combined with one group control board "BL2000-QKB-V1" and several integrated controllers in every elevator in the group. Group controller collect hall call, car call and status information of every elevator through CAN BUS, process them, and deliver distribution orders to every elevator. In this way the group control for up 8 elevators & 64 floors is achieved.
2. Four Running Modes
 - ◆ Up peak mode: At set time, all elevators answer landing call with up call from base floor has highest priority.
 - ◆ Down peak mode: At set time, one elevator answer up call with priority; other elevators answer down call (one elevator on each area) with priority to minimize the down call reaction time.
 - ◆ Balance mode: Landing call distribution is optimized according to shortest time response principle.
 - ◆ Spare mode: 3 minutes at the balance mode without landing/car call, elevator will wait for the order from the first floor on each area so that it can response to hall car as soon as possible.

When elevator is at status of fault, attendant, inspection, parking, fire and special use mode, it will be excluded from the group control. Please follow the relevant chapter in this user guide for individual elevator operation in group control mode.

11.2.2 Application

1. Group Control from 3 to 8 elevators;
2. Elevator speed 0.5-4m/s;
3. Can be used up to 64 floors;
4. Applies to passenger and residential elevator.

11.2.3 Terminal Specification

5. J1 Multiple Wire Socket DK5EHDRC-10P; Rated Voltage: 300V, Rated Current: 15A, Max Voltage: 4KV, Leg: 5mm.
6. J2 Connector 2.54/3P
7. J3 Twin housing 2.54/10P
8. J4 Connector 2.54/5P
9. J5 Single shield plug-in 3.96/4P

11.2.4 Interface Circuit

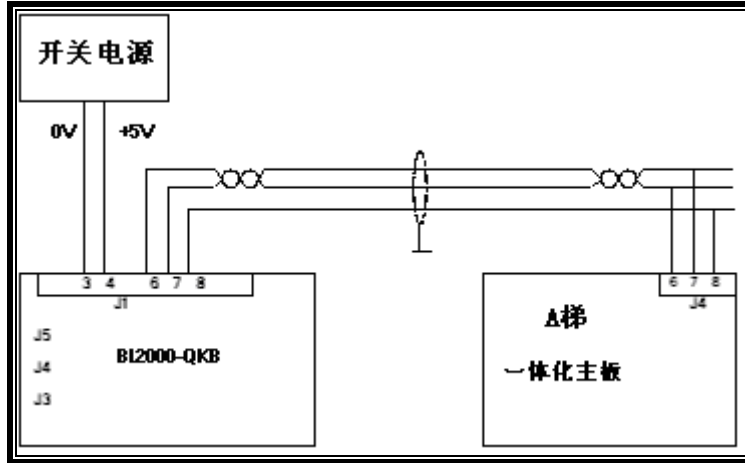

Figure 11.21 Group Control Board BL2000-QKB-V1 Interface Circuit

11.2.5 Terminal Definition & Specification

Table 11.6 Group Control Board BL2000-QKB-V1 Terminal Definition & Specification List

| Name | Terminal | Location | Definition | Usage | Technical Specification | | |
|------|-----------------------|----------|-----------------------------|-----------------------|-------------------------|------------|-----------|
| | | | | | Interface Type | Rated Load | Max Speed |
| J1 | GND3 | J1-1 | 0V | Power & Communication | | | |
| | | J1-2 | | | | | |
| | GND3 | J1-3 | 0V | | | | |
| | 5V IN | J1-4 | 5V Input | | | 200mA | |
| | | J1-5 | | | | | |
| | TXA+ | J1-6 | Group Control Communication | | | | |
| | TXA- | J1-7 | | | | | |
| | GND3 | J1-8 | 0V | | | | |
| | | J1-9 | Spare CAN Comm. TXA+ | | | | |
| | | J1-10 | Spare CAN Comm. TXA- | | | | |
| J2 | DA+ | J2-1 | | RS485 | | | |
| | DA- | J2-2 | | | | | |
| | GND | J2-3 | | | | | |
| J3 | Programming Interface | | | | | | |
| J4 | TX | J4-1 | Communication Send | RS323 | | | |
| | RX | J4-2 | Communication Receive | | | | |
| | IN | J4-3 | Control Input | | | | |
| | OUT | J4-4 | Control Output | | | | |
| J5 | TXA+ | J5-1 | Group Communication | | | | |
| | TXA- | J5-2 | | | | | |
| | GND3 | J5-3 | 0V | | | | |
| | | J5-4 | | | | | |

Appendix 1: Hoistway Switches Information (partly)

F1.1. Leveling Switches & Flag Installation

For elevator leveling control, two leveling switches (up/down leveling switches) and some door zone flags (one in each floor) are required. Two leveling switches are installed on top of car, door zone flag is installed in hoistway, their dimensions and positions are illustrated in figure F1.1. Leveling switches can be optical or magnetic.

Door zone flag adjustment:

1. Elevator stop at each floor, measure car and hall sills difference ΔS on each level at elevator park (car sills higher is position, lower is negative)
2. Adjust door zone flag on each floor, if $\Delta S > 0$, flag on this floor should move down ΔS ; move flag up ΔS if $\Delta S < 0$.
3. Elevator need to redo the hoistway parameter learning after door zone flag adjustment.
4. Check elevator leveling on each floor, redo part 1-3 if necessary.

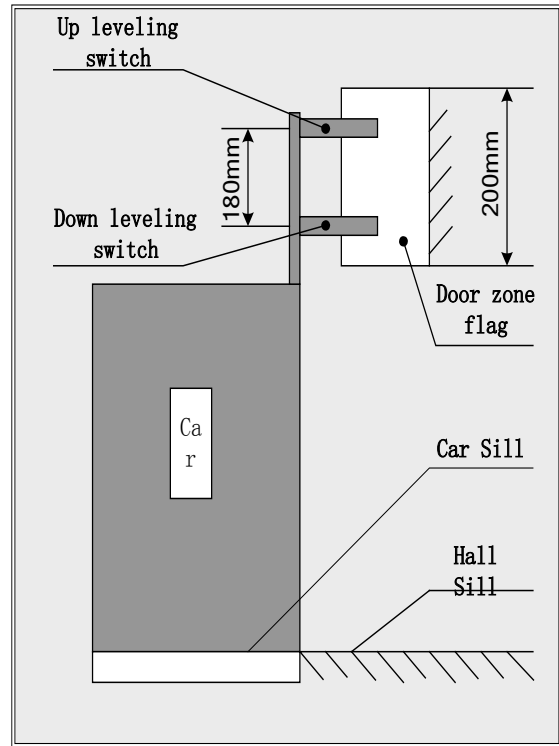

Figure F1.1 Door zone flag & Leveling Switch Position

F1.1. Up/Down Terminal Switches Installation

1. Terminal switches are recommended to use non-contact type, such as magnetic switch.
2. Up/Down terminal switches are installed in hoistway guide rail; terminal flag is installed on top of car. Their positions are shown below in figure F1.2 & F1.3.
3. For elevator speed $\leq 1.75\text{m/s}$, only one up and one down terminal switch and one terminal flag is required. For elevator speed $\geq 2.0\text{m/s}$, more terminal switches should be installed for safety purpose. Please see below table F1.1 for up/down terminal switches position with different elevator speed.

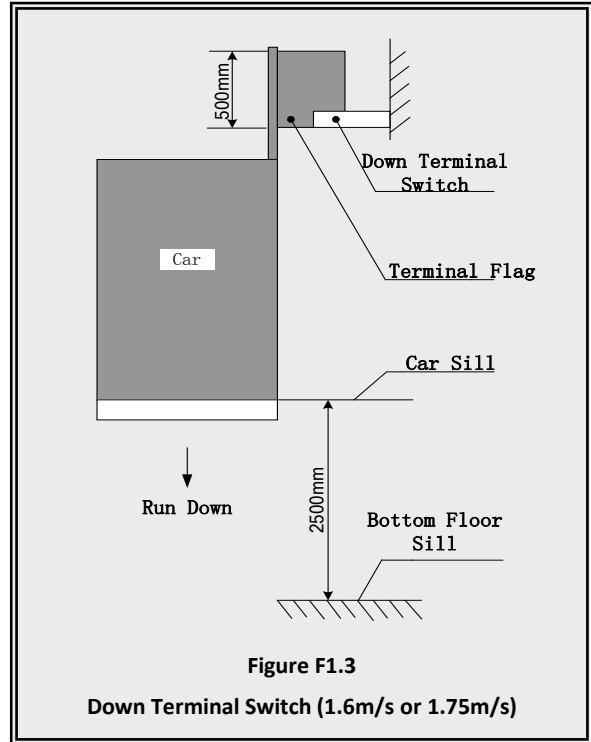
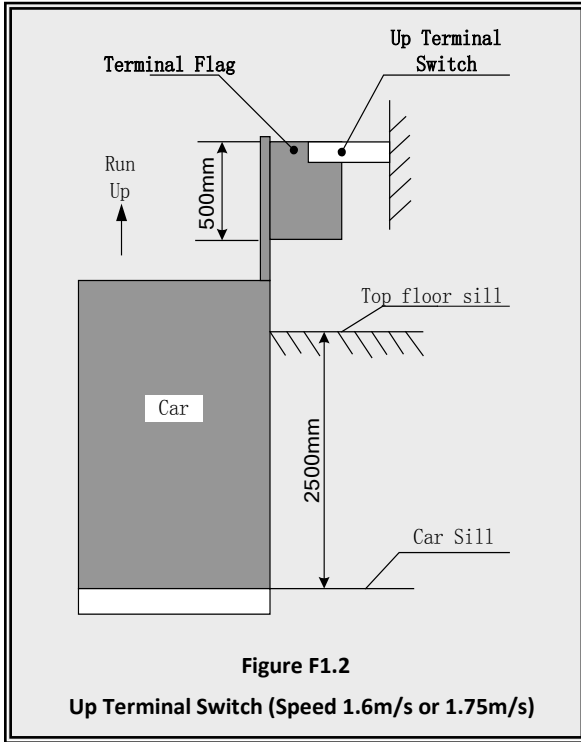

Table F1.1 Up/Down Terminal Switches with different elevator speed

| Speed Terminal | Terminal Switch Location | | | | | |
|---------------------------|--------------------------|--------|-------------------|--------|-----------|--------|
| | 0.5m/s | 1.0m/s | 1.6m/s 1.75m/s | 2.0m/s | 2.5m/s | 4.0m/s |
| Up/Down Terminal Switch 1 | 1m | 1.3m | 2.5m | 2.5m | 2.5m | 2.5m |
| Up/Down Terminal Switch 2 | | | | 4m | 6.25m(4m) | 8m |
| Up/Down Terminal Switch 3 | | | | | | |

F1.2. Confirm the Terminal Switches Location

Up/down terminal switches signal is used for elevator force change speed and floor position calibration, they should be installed 2.5m from car top/bottom to top/bottom floor leveling position. (For elevator speed at 1.6m/s or 1.75m/s). To confirm such position:

1. Make sure elevator in inspection mode;
2. Set inspection speed to 0.3m/s , run up/down elevator;
3. Stop elevator when touching up/down terminal switches;
4. At this time the car sills and hall sills should have a distance of 2.5±0.1m.

Appendix 2: Parameters List

Table F2.1 Controller Parameters & Factory Setting List

| Parameter | Name | Default Value | Set Value |
|-----------|---|---------------|-----------|
| U0-00 | Lower Limit | 0 | |
| U0-01 | Upper Limit | 0 | |
| U0-02 | Lower Slowdown 1 | 0 | |
| U0-03 | - | 0 | |
| U0-04 | Upper Slowdown 1 | 0 | |
| U0-05 | - | 0 | |
| U0-06 | Floor Data 1 | 0 | |
| U0-07 | Floor Data 2 | 0 | |
| U0-08~68 | Floor Data 3~63 | 0 | |
| U0-69 | Floor Data 64 | 0 | |
| U1-00 | Input Data | -- | |
| U1-01 | Input Bin | -- | |
| U1-02 | Input App | -- | |
| U2-00 | Output Data | -- | |
| U3-00 | Car Input Data | -- | |
| U4-00 | Run Times | 0 | |
| U4-01 | Run Hours | 0 | |
| U4-04 | CAN1SendAPP | -- | |
| U4-05 | CAN1ReceiveAPP | -- | |
| U4-06 | Interfer Apprais | -- | |
| U4-07 | Encoder Apprais | -- | |
| U4-09 | Loading Data | | |
| U5-00 | Ctrsoftware NO | -- | |
| U5-01 | DriveCodeVer | -- | |
| U5-02 | CpldEdition | -- | |
| U6-00 | Power | -- | |
| U6-01 | Ref Speed | -- | |
| U6-02 | Feedback Speed | -- | |
| U6-03 | Load | -- | |
| U6-04 | DC Voltage | -- | |
| U6-05 | Output current | -- | |
| U6-06 | temperature | -- | |
| U6-07 | Output torque | -- | |
| F0-00 | Total floor | 6 | |
| F0-01 | Homing Floor | 1 | |
| F0-02 | Fire floor | 1 | |
| F0-03 | Parking floor | 1 | |
| F0-04 | Display Code | 0 | |
| F0-05 | 1 st floor indicator setting | 1 | |

Table F2.1 Controller Parameters & Factory Setting List (Cont'd)

| Parameter | Name | Default Value | Set Value |
|-----------|--|----------------------|-----------|
| F0-xx | Xxth floor indicator setting | 1~63 | |
| F0-68 | 64 th floor indicator setting | 64 | |
| F1-00 | Car speed | 1.60m/s | |
| F1-01 | Motor speed | 1450r | |
| F1-03 | Insp speed | 0.3m/s | |
| F1-04 | Start speed | 0m/s | |
| F1-05 | Leveling Speed | 0.3m/s | |
| F1-06 | Least Speed | 0.96m/s | |
| F1-07 | Open Door Speed | 0.25m/s | |
| F1-08 | Relevelst Speed | 0.30m/s | |
| F1-09 | Relvelrun speed | 0.05m/s | |
| F1-10 | Acceleration B1 | 0.7m/s ² | |
| F1-11 | Deceleration B2 | 0.7 m/s ² | |
| F1-12 | S Curve P1 | 0.6 m/s ³ | |
| F1-13 | S Curve P2 | 0.6 m/s ³ | |
| F1-14 | S Curve P3 | 0.6 m/s ³ | |
| F1-15 | S Curve P4 | 0.6 m/s ³ | |
| F1-16 | Zero Speed | 1RPM | |
| F1-17 | Leveling Adj | 50mm | |
| F1-18 | Load Adj | 0 | |
| F1-21 | Drive mode | 0 | |
| F1-22 | Two Door Mode | 0 | |
| F1-23 | Fire Mode | 0 | |
| F1-24 | Parallel No. | 0 | |
| F1-25 | Twins Control | 0 | |
| F1-26 | Group Control | 0 | |
| F1-27 | Far monitor | 0 | |
| F1-28 | Auto Parking | 0 | |
| F1-29 | Load Enable | 0 | |
| F1-30 | Open Delay Time | 0 | |
| F1-31 | Brake Feedback | 0 | |
| F1-32 | Solution Ladder Password | 0 | |
| F2-00 | Brake ON Time | 0.5s | |
| F2-01 | Brake OFF Time | 0.5s | |
| F2-02 | Insp Brake Time | 0.5s | |
| F2-04 | Zero Time | 0.3ms | |
| F2-05 | Open Door time | 3s | |
| F2-06 | Open Delay Time | 60s | |
| F2-07 | Homing Time | 60s | |
| F2-08 | Door Run Timse | 5s | |

Table F2.1 Controller Parameters & Factory Setting List (Cont'd)

| Parameter | Name | Default Value | Set Value |
|-----------|---------------------|---------------|-----------|
| F2-09 | Beep Delay Time | 0.15s | |
| F2-10 | Enable Delay | 0s | |
| F2-11 | Lamp Off Time | 15min | |
| F2-12 | Over Time | 45s | |
| F2-13 | Smooth Start Time | 0 | |
| F2-14 | Start Time/Hour | 00 | |
| F2-15 | Start Time/Minute | 00 | |
| F2-16 | Stop Time/Hour | 00 | |
| F2-17 | Stop Time/Minute | 00 | |
| F2-18 | Start Time 1/Hour | | |
| F2-19 | Start Time 1/Minute | | |
| F2-20 | Stop Time 1/Hour | | |
| F2-21 | Stop Time 1/Minute | | |
| F3-00 | Input type | -- | |
| F3-01 | Car input type | -- | |
| F3-02 | Input select 1 | 19 | |
| F3-03 | Input select 2 | 22 | |
| F3-04 | Input select 3 | 23 | |
| F3-05 | Input select 4 | 24 | |
| F3-06 | Input select 5 | 25 | |
| F3-07 | Output select 1 | 0 | |
| F3-08 | Output select 2 | 11 | |
| F3-09 | Output select 3 | 12 | |
| F4-00 | Set Stop Floor1 | 0xFFFFFFFF | |
| F4-01 | Set Stop Floor2 | 0xFFFFFFFF | |
| F4-02 | TIM Stop Floor1 | 0x00000000 | |
| F4-03 | TIM Stop Floor2 | 0x00000000 | |
| F4-04 | Door Select A1 | 0xFFFFFFFF | |
| F4-05 | Door Select B1 | 0xFFFFFFFF | |
| F4-06 | Function Select | 4 | |
| F4-07 | Function Select 2 | 0 | |
| F5-00 | Motor type | -- | |
| F5-01 | Poles | -- | |
| F5-02 | Rated Freq | -- | |
| F5-03 | Motor rated power | -- | |
| F5-04 | rated speed | -- | |
| F5-05 | V IN | -- | |
| F5-06 | L_phase | -- | |
| F5-07 | R_phase | -- | |
| F5-08 | Rated FLA | -- | |
| F5-09 | non-load current | -- | |

Table F2.1 Controller Parameters & Factory Setting List (Cont'd)

| Parameter | Name | Default Value | Set Value |
|-----------|------------------|---------------|-----------|
| F5-10 | slip frequency | 1.3HZ | |
| F6-00 | Carrier Freq | 8HZ | |
| F6-02 | Speed Zoom | 100% | |
| F6-03 | DirSel | 0 | |
| F6-04 | Kp | 220 | |
| F6-05 | KI | 110 | |
| F7-00 | PIMulEnable | 0 | |
| F7-01 | PI1 Range | 0 | |
| F7-02 | PI2 Range | 0 | |
| F7-04 | PI3 Range | 0 | |
| F7-05 | Kp1 | 300 | |
| F7-06 | Kx1 | 200 | |
| F7-07 | Kp2 | 300 | |
| F7-08 | Kx2 | 200 | |
| F7-11 | Kp3 | 300 | |
| F7-12 | Kx3 | 200 | |
| F8-00 | Encoder PPR | 8192 | |
| F8-02 | PG Type | 0 | |
| F9-00 | Max Torq Comp | 0% | |
| F9-01 | SPD SourceSel | 2 | |
| F9-03 | Spderr Set | 10% | |
| F9-11 | Load Comp Enable | 0 | |
| F9-13 | Load Source Sel | 0 | |
| F9-14 | Fan Mode | 1 | |
| F9-19 | UP Comp Bias | 0 | |
| F9-20 | DOWN Comp Bias | 0 | |
| F9-21 | FULL Comp Pro | 100% | |
| FA-00 | Strat KP | 30 | |
| FA-01 | Stra tKI | 750 | |
| FA-08 | PLKP | 3600 | |
| FA-09 | PL Time | 900ms | |
| FA-11 | Integral Gain | 800 | |
| FA-12 | Flux Gain | 125 | |
| A0-00 | Language Sel | 0 | |
| A0-01 | User Password | 000000 | |
| A0-02 | Factory password | -- | |
| A0-03 | Set Quick Menu | 000000 | |
| A0-04 | Contrast | 5 | |

Appendix 3: Hoistway Parameter Learning Flowchart



This function is only valid for controller with software version 6017 & above.

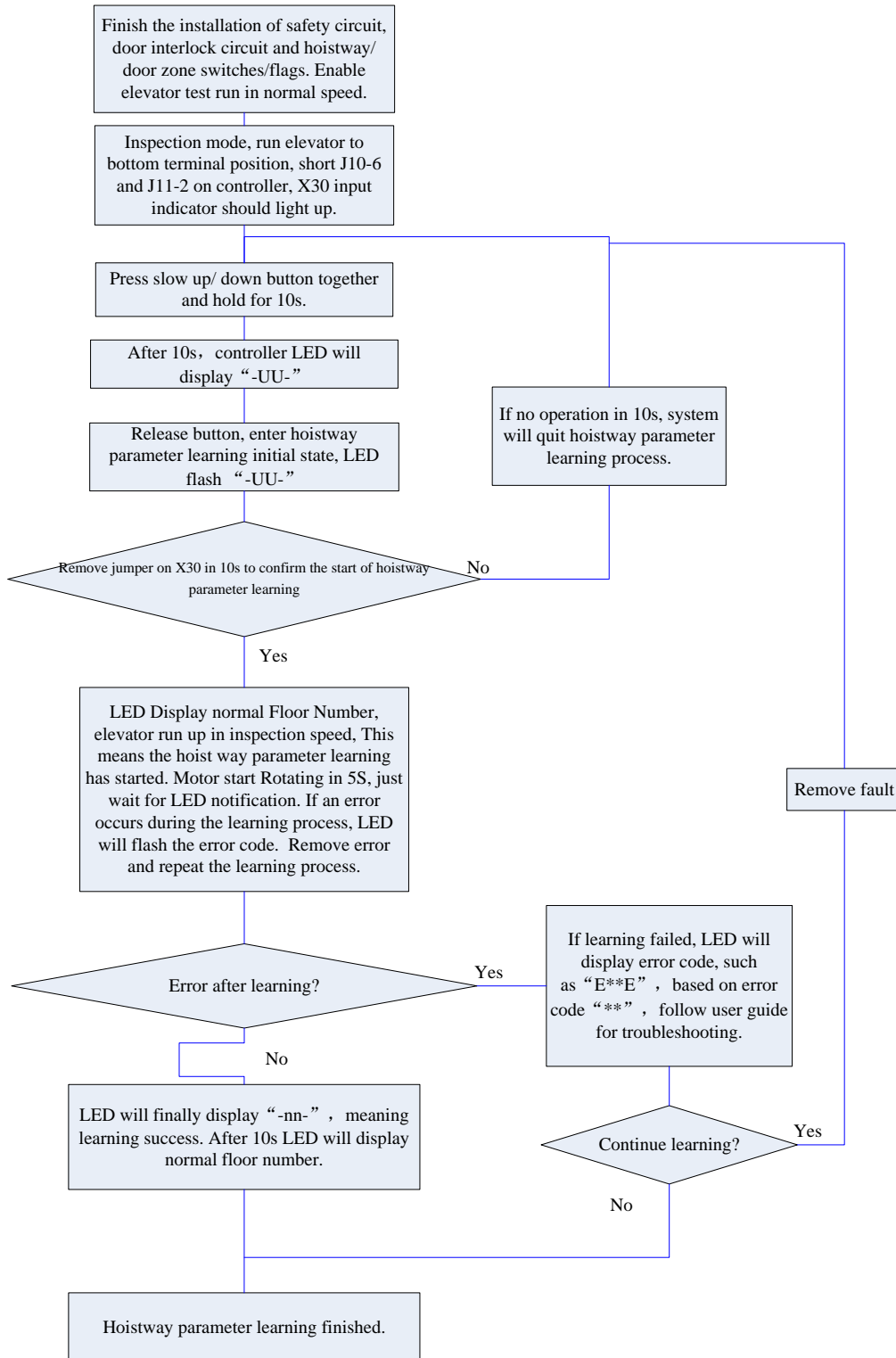

Please make sure all door zone, terminal, limit, final limit signals are correctly connected & tested before integrated controller perform the hoistway parameter learning process.

Appendix 4: Motor Initial Angle Static Tuning Flowchart



1. This function is only valid for integrated controller with MU-V5 board
2. Before following procedures below, please make sure the integrated controller logic program version is 6014 or above, and drive program version is 52 or above. Otherwise this function is not supported.
3. Before following procedures below, please fill in the machine basic parameters (F5) and PG interface card parameters (F8). Please set the machine tuning mode to static tuning.

